

Village of Lemont

Mayor
Brian K. Reaves

Village Clerk
Charlene Smollen

Administrator
George J. Schafer



Trustees
Debby Blatzer
Paul Chialdikas
Clifford Miklos
Rick Sniegowski
Ronald Stapleton
Jeanette Virgilio

VILLAGE BOARD MEETING

May 12, 2014 – 7:00 PM
Village Hall – 418 Main Street

AGENDA

- I. PLEDGE OF ALLEGIANCE**
- II. ROLL CALL**
- III. CONSENT AGENDA**
 - A. APPROVAL OF MINUTES**
 - 1. APRIL 14, 2014 VILLAGE BOARD MEETING MINUTES**
 - 2. APRIL 21, 2014 COMMITTEE OF THE WHOLE MEETING MINUTES**
 - B. APPROVAL OF DISBURSEMENTS**
 - C. AN ORDINANCE AMENDING TITLE 10 OF THE LEMONT, ILLINOIS MUNICIPAL CODE RELATING TO PARKING**
 - D. AN ORDINANCE GRANTING A VARIATION TO ALLOW A DETACHED GARAGE ACCESS FROM A STREET (PEIFFER AVE.) AS OPPOSED TO AN ALLEY AS REQUIRED IN THE R-4A DISTRICT FOR THE PROPERTY LOCATED AT 931 SINGER AVE. IN LEMONT, IL (931 SINGER AVE.)**
 - E. AN ORDINANCE AMENDING TITLE 17 OF THE LEMONT MUNICIPAL CODE, THE LEMONT UNIFIED DEVELOPMENT ORDINANCE OF 2008 (UDO AMENDMENTS)**
 - F. AN ORDINANCE AMENDING TITLE 1 OF THE LEMONT, ILLINOIS MUNICIPAL CODE RELATING TO GENERAL PENALTY AND LATE FEES**
 - G. A RESOLUTION APPROVING LICENSE AGREEMENT WITH INTEGRITY SECURITY PERSONNEL CONCEAL CARRY, INC.**
 - H. A RESOLUTION AMENDING ICMA RETIREMENT CORPORATION SECTION 457 DEFERRED COMPENSATION PLAN #303572 TO PERMIT LOANS**

IV. MAYOR'S REPORT

- A. LIFE SAVING AWARD FOR OFFICER BRIAN SCHMITZ**
- B. PROCLAMATION – MUNICIPAL CLERKS WEEK MAY 4-10**
- C. PROCLAMATION – POLICE WEEK MAY 11-17**
- D. PROCLAMATION – PUBLIC WORKS WEEK MAY 18-24**
- E. PROCLAMATION – COPS ON THE ROOF TOP DAY MAY 30**
- F. PROCLAMATION – MOTORCYCLE AWARENESS MONTH OF MAY**
- G. AUDIENCE PARTICIPATION**

V. CLERK'S REPORT

A. CORRESPONDENCE

- 1. 2014-2015 VILLAGE BOARD MEETING CALENDAR**

B. ORDINANCES

- 1. ADOPTION OF AN ORDINANCE AUTHORIZING THE ISSUANCE OF INCREMENTAL TAXES / GENERAL SALES TAXES / REVENUE SHARING RECEIPTS ALTERNATE REVENUE SOURCE BONDS OF THE VILLAGE OF LEMONT, COOK, DUPAGE AND WILL COUNTIES, ILLINOIS, FOR THE PURPOSE OF REFINANCING GATEWAY TIF REDEVELOPMENT PROJECT COSTS, AND RELATED FACILITIES, IMPROVEMENTS AND COSTS
(ADMIN/FINANCE)(REAVES/SNIEGOWSKI)(SCHAFFER/SMITH)**
- 2. AN ORDINANCE APPROVING AN ECONOMIC DEVELOPMENT GRANT FOR 431 TALCOTT AVENUE IN LEMONT, IL
(P&ED)(STAPLETON)(JONES)**

C. RESOLUTIONS

- 1. A RESOLUTION AUTHORIZING AWARD OF CONTRACT - WARNER AVENUE WATER MAIN REPLACEMENT – PHASE 1 - SOUTH OF WEIMER AVENUE TO PEIFFER AVENUE
(PUBLIC WORKS)(BLATZER)(PUKULA)**
- 2. A RESOLUTION AUTHORIZING AWARD OF CONTRACT - WARNER AVENUE WATER MAIN REPLACEMENT – PHASE 2 - PEIFFER AVENUE TO NORTH AVENUE
(PUBLIC WORKS)(BLATZER)(PUKULA)**
- 3. A RESOLUTION AUTHORIZING AWARD OF CONTRACT – EAST STREET WATER MAIN REPLACEMENT AT SHORT STREET
(PUBLIC WORKS)(BLATZER)(PUKULA)**

**4. A RESOLUTION AUTHORIZING AWARD OF CONTRACT – 2014 CDBG SIDEWALK
REPLACEMENT – BLOCK GROUP 3 – CDBG PROJECT No. 1306-014
(PUBLIC WORKS)(BLATZER)(PUKULA)**

- VI. VILLAGE ATTORNEY REPORT**
- VII. VILLAGE ADMINISTRATOR REPORT**
- VIII. BOARD REPORTS**
- IX. STAFF REPORTS**
- X. UNFINISHED BUSINESS**
- XI. NEW BUSINESS**
- XII. MOTION FOR EXECUTIVE SESSION**
- XIII. ACTION ON CLOSED SESSION ITEM(S)**
- XIV. MOTION TO ADJOURN**

Minutes
VILLAGE BOARD MEETING
April 14, 2014

The regular meeting of the Lemont Village Board was held on Monday, April 14, 2014, at 7:00 p.m., presided by Mayor Brian Reaves.

I. PLEDGE OF ALLEGIANCE

II. ROLL CALL

Roll call: Chialdikas, Miklos, Sniegowski, Stapleton, Virgilio, Blatzer; present.

III. CONSENT AGENDA

Motion by Miklos, seconded by Virgilio, to approve the following items on the consent agenda by omnibus vote:

A. Approval of Minutes

A. March 24, 2014 Village Board Meeting Minutes

B. Approval of Disbursements

C. Ordinance O-21-14 Authorizing the Annual Fee Ordinance.

D. Ordinance O-22-14 Adopting Amending Ordinance 725 Establishing a Pay Plan and Schedule of Authorized Positions.

E. Ordinance O-23-14 Authorizing the Agreement for Sale and Purchase of Certain Real Property Known as 10980 Archer Avenue.

F. Ordinance O-24-14 Authorizing the Acquisition of a Water System.

G. Resolution R-18-14 Approving the Implementation of a Public, Educational and Governmental (PEG) Capital Fee.

Roll Call: Chialdikas, Miklos, Sniegowski, Stapleton, Virgilio, Blatzer; 6 ayes. Motion Passed.

IV. MAYOR'S REPORT

A. Motion by Miklos, seconded by Chialdikas to approve a Proclamation declaring May 1 National Day of Prayer. Voice Vote: 6 ayes. Motion passed.

B. Audience Participation

1. Janet Hughes, 1283 Abby Oaks Dr., had three questions, two of which can be answered on the website. Mayor Reaves answered the question regarding the sports complex.

2. Dave Blomgren, 529 Keepataw Dr., wants the Village residents to vote on the sports complex.

V. CLERK'S REPORT

A. CORRESPONDENCE

1. Attended the Southwest Municipal Clerk's Meeting in Chicago Ridge on April 3rd
2. Attended the MCI Spring Seminar in Oakbrook Hills on April 10 & 11th.

B. ORDINANCES

1. Ordinance O-25-14 Adopting the FY 2014-2015 Operating and Capital Improvement Budget for the Village of Lemont. Motion by Sniegowski, seconded by Stapleton, to adopt said Ordinance. Roll call: Chialdikas, Miklos, Sniegowski, Stapleton, Virgilio, Blatzer; 6 ayes. Motion Passed.

C. RESOLUTIONS

1. Resolution R-19-14 Approving Refuse, Recycling, and Landscape Waste Collection and Disposal Agreement with Waste Management. Motion by Stapleton, seconded by Blatzer, to adopt said Resolution. Roll call: Chialdikas, Miklos, Sniegowski, Stapleton, Virgilio, Blatzer; 6 ayes. Motion Passed.

VI. VILLAGE ATTORNEY REPORT

VII. VILLAGE ADMINISTRATOR REPORT

VIII. BOARD REPORTS

- A. Trustee Sniegowski thanked Chris Smith and George Schafer for their work on the budget.
- B. Jeanette Virgilio – Made mention that the Quarryman Challenge will be on Saturday, May 10th. Volunteers are still needed.

IX. STAFF REPORTS

X. UNFINISHED BUSINESS

XI. NEW BUSINESS

XII. MOTION FOR EXECUTIVE SESSION

Motion by Chialdikas, seconded by Stapleton, to move into Executive Session(s) for the purpose of discussing Personnel and Collective Bargaining. Roll Call: Chialdikas, Miklos, Sniegowski, Stapleton, Virgilio, Blatzer; 6 ayes. Motion Passed.

XIII. ACTION ON CLOSED SESSION ITEM

Motion by Virgilio, seconded by Blatzer to approve the Commission appointments (attached). Voice Vote; 6 ayes. Motion passed.

XIV. MOTION TO ADJOURN

There being no further business, a motion was made by Blatzer, seconded by Stapleton, to adjourn the meeting at 8:40 p.m. Voices vote; 6 ayes. Motion passed.

Term Expires	Last Name	First Name	Commission
2014	Cardona-Tapia	Carla	Art & Culture
2014	Christain	Emily J.B.	Art & Culture
2014	Albrecht	Chris	Environmental Advisory
2014	Carusiello	Elva	Environmental Advisory
2014	Thomas	Tom	Environmental Advisory
2014	Splitt	Robert	Ethics
2014	Moeller	David	Heritage Committee
2014	Quinn	John	Heritage Committee
2014	Wozniak	Fraink	Liquor Control Review Board
2014	Kwasneski	Ryan	Planning & Zoning Commission
2014	Messer	Greg	Planning & Zoning Commission
2014	Sanderson	Jason	Planning & Zoning Commission
2014	Falese	Joseph	Police Commission
2014	Buschman	Barbara	Police Pension Board

**COMMITTEE OF THE WHOLE MEETING
APRIL 21, 2014**

A Meeting of the Village of Lemont Committee of the Whole was held on Monday, April 21, 2014 in the Lemont Village Hall Board Room at 418 Main Street, Lemont, Illinois.

I. CALL TO ORDER – Mayor Reaves called the meeting to order at 7:00 p.m.

II. ROLL CALL – Trustees Debby Blatzer, Paul Chialdikas, Cliff Miklos, Rick Sniegowski, Ron Stapleton and Jeanette Virgilio were present.

Also present were Village staff members George Schafer, Martha Glas, Charity Jones, Mark LaChappell, Linda Molitor, Ralph Pukula, Kevin Shaughnessy and Chris Smith.

III. DISCUSSION ITEMS

A. 931 Singer Ave. Variation

A variation is being requested to allow a proposed detached garage to be accessed from the street as opposed to the alley as required in the R-4A district by code. The currently vacant property is a corner lot in which a home and detached garage will be constructed on the property. The applicant is requesting access to the garage off of Peiffer Ave. The Village Board was in agreement with recommending approval.

B. Birch Path PUD & Annexation and Rezoning Discussion

The developer of Birch Path previously requested a preliminary PUD plan for approval, and discussions with PZC and COW were previously held. A PZC Public Hearing was held on November 20, 2013. The Planning & Zoning Commission added supplemental conditions to the plan, but did not recommend approval. At the December 16, 2013 Committee of the Whole Meeting, discussion continued on the concerns, and outstanding items in which the PUD will not be approved until these items are addressed to the satisfaction of the Village Board.

At this April 21 COW Meeting, staff reviewed the Case History Summary noting the outstanding items from 12/16/13, and discussed the Current Status; each of which is included in the 4/21/14 agenda report. The petitioner submitted a revised site plan with preliminary engineer noting the changes/recommendations. Discussion took place regarding the items which will again be incorporated into the site plan. The PUD will be up for preliminary plat approval at a future Village Board Meeting.

C. Refunding General Obligation Bonds Series 2005 (Sales Tax ARS) and Series 2012B Gateway TIF Discussion

The General Obligation Bonds Series 2005 are callable on September 1, 2014. Bob Vail of Bernardi Securities presented the refinancing and restructuring summaries indicating an estimated savings of \$55,470.00. The 2012B Gateway TIF bonds need to be restructured to match the TIF increment and the marketability of the acquired properties for a \$4,135 savings. The Village Board was in agreement of the refunding and restructuring of the bonds.

D. Eagle Crest Parking

A pilot restricted parking was done last year on the east side of Eagle Crest and it was successful. It is staff's recommendation to make this one side parking permanent during the months of May 1 through October 1 in which parking will be permitted only on the west side of Eagle Crest. The Board suggested that due to the extended activities at the Park District to make it the months of May 1 – November 1. The item will be approved at a future Village Board Meeting.

E. Canal Lease Process

There are four properties which reside on a portion of the canal area which the village leases to. Kallemeyn Collission has a lease that is issued through 2018. Staff would like to make the remaining three leases to be issued through 2018 as well. In addition, staff intends to reassess the amount billed per square foot. The Village Board would like to leave the remaining leases as an annual lease agreement.

F. Channel 6 Program and Vehicle Donation

The Fire Department offered to donate a vehicle to use for a production van. Discussion took place on the feasibility of utilizing this vehicle, but was determined that the Village would not be able to utilize it at this time due to the size, cost to convert it and driver license class limitations.

IV. OLD BUSINESS - None

V. NEW BUSINESS

A. MI Homes

Residential design considerations at Kettering were discussed. They intend to sell off larger lots to other builders.

B. Pension Board

The Board was informed that the Pension Board adopted/revised their investment policy.

C. Emerald Ash Trees

Public Works will determine the priority of those infested trees. The trees need to bud first, so the timing will be at the end of May. Residents can contact the Public Works department to inform them of infested trees which Public Works will then log and monitor. Residents can plant their own trees, but the type would need to be approved.

D. Logan Street Parking

Residents have complained about the two-sided parking on Logan Street. It is the only street around the church that allows two-sided parking.

E. Sports Complex

We are waiting on MWRD regarding direction for cleanup of the property. Mesirow is running the numbers based on the scope of the project.

F. I&M Canal Wall

Public Works and Engineering will talk to some engineers regarding repair of a portion of the I&M Canal wall.

Meeting adjourned at 9:00 PM.

Lemont, IL
Warrant list

Bank Account: Clearing - Accounts Payable

Batch Date: 04/28/2014

Type	Date	Number Source	Payee Name	EFT Bank/Account	Transaction Amount
Bank Account: Clearing - Accounts Payable					
Check	04/28/2014	8414 Accounts Payable	Airgas USA, LLC		18.91
	Invoice	Date	Description		Amount
		9917750032	03/31/2014	welding tank rental	18.91
Check	04/28/2014	8415 Accounts Payable	Arrow Sign Company Inc		3,200.00
	Invoice	Date	Description		Amount
		14-04-18	04/18/2014	Parking Garage sign	3,200.00
Check	04/28/2014	8416 Accounts Payable	Arthur Peterson, Inc.		26.76
	Invoice	Date	Description		Amount
		14-03-31	03/31/2014	Mar 2014 purchases	26.76
Check	04/28/2014	8417 Accounts Payable	AT&T Capital Services, Inc.		295.84
	Invoice	Date	Description		Amount
		2915021	04/01/2014	001-5284700-001 - iPads lease payment	295.84
Check	04/28/2014	8418 Accounts Payable	AT&T Illinois		645.57
	Invoice	Date	Description		Amount
		63024304480414	04/13/2014	630 243-0448 146 1 chestnut crossing l/s	64.85
		63024304590414	04/13/2014	630 243-0459 681 3 oak tree l/s	71.21
		63024373750414	04/13/2014	630 243-7375 749 4 art & culture commission	100.97
		63024312300414	04/13/2014	630 243-1230 805 2 eagle ridge l/s	67.81
		63024314680414	04/13/2014	630 243-1468 926 9 parking garage	141.32
		63024316090414	04/13/2014	630 243-1609 403 9 kohls-target l/s	56.81
		63024317390414	04/13/2014	630 243-1739 155 8 well #6	142.60
Check	04/28/2014	8419 Accounts Payable	AT&T Illinois		55.00
	Invoice	Date	Description		Amount
		14-04-02	04/02/2014	126379005 - metra station internet	55.00
Check	04/28/2014	8420 Accounts Payable	AT&T Mobility		1,443.87
	Invoice	Date	Description		Amount
		04112014	04/03/2014	287249463396 - p.w. cell phone service	1,443.87
Check	04/28/2014	8421 Accounts Payable	Avalon Petroleum Company		12,138.51

Lemont, IL
Warrant list

Bank Account: Clearing - Accounts Payable
Batch Date: 04/28/2014

Type	Date	Number Source	Payee Name	EFT Bank/Account	Transaction Amount
	Invoice		Date	Description	Amount
	014690		04/07/2014	1500 gals dsl fuel	5,115.00
	552240		04/07/2014	2001 gals unl fuel	7,023.51
Check	04/28/2014	8422 Accounts Payable	B&H Photo		197.85
	Invoice		Date	Description	Amount
	81827040		04/04/2014	narcan spray	131.90
	81970206		04/09/2014	narcan spray	65.95
Check	04/28/2014	8423 Accounts Payable	Ballard , Thomas		210.28
	Invoice		Date	Description	Amount
	14-04-16		04/16/2014	reimbursement - IESMA conference	210.28
Check	04/28/2014	8424 Accounts Payable	Battery Service Corp.		248.75
	Invoice		Date	Description	Amount
	242822		04/02/2014	parts	248.75
Check	04/28/2014	8425 Accounts Payable	Bourbonnais Supply Inc.		106.88
	Invoice		Date	Description	Amount
	162255		04/10/2014	part & repair	106.88
Check	04/28/2014	8426 Accounts Payable	Braniff Communications Inc.		2,420.00
	Invoice		Date	Description	Amount
	0027918		03/26/2014	siren replacement - labor	2,420.00
Check	04/28/2014	8427 Accounts Payable	Call One		1,491.38
	Invoice		Date	Description	Amount
	14-04-15		04/15/2014	1010-7801-0000 v.h., p.d., p.w. phones	1,491.38
Check	04/28/2014	8428 Accounts Payable	CCP Industries, Inc.		130.39
	Invoice		Date	Description	Amount
	IN01256429		04/04/2014	uniforms	130.39
Check	04/28/2014	8429 Accounts Payable	Celina's Fresh Market		28.72
	Invoice		Date	Description	Amount
	14-04-16		04/16/2014	SWCD meeting food	28.72
Check	04/28/2014	8430 Accounts Payable	Chicago Parts Sound, LLC		249.60

Lemont, IL
Warrant list

Bank Account: Clearing - Accounts Payable

Batch Date: 04/28/2014

Type	Date	Number Source	Payee Name	EFT Bank/Account	Transaction Amount
	Invoice		Date	Description	Amount
	586197		04/09/2014	parts	162.79
	586644		04/10/2014	parts	86.81
Check	04/28/2014	8431 Accounts Payable		Chicago Street CCDD, LLC	460.00
	Invoice		Date	Description	Amount
	8380		04/14/2014	dumping fees	460.00
Check	04/28/2014	8432 Accounts Payable		Cintas Corporation	77.36
	Invoice		Date	Description	Amount
	8400928318		04/04/2014	v.h. shredding	77.36
Check	04/28/2014	8433 Accounts Payable		Comcast Cable	490.81
	Invoice		Date	Description	Amount
	14-04-2700		04/04/2014	8771 20 147 0042700 p.d. cable/internet	248.98
	14-04-9805		04/04/2014	8771 20 147 0039805 v.h. cable/internet	241.83
Check	04/28/2014	8434 Accounts Payable		ComEd	5,338.51
	Invoice		Date	Description	Amount
	14-04-3016		04/07/2014	9338003016 - street lights - houston 1N schultz	17.73
	14-04-7033		04/15/2014	2213017033 - street lights - bell rd, main st	720.11
	14-04-2063		04/09/2014	1443022063 - street lights - KA Steel path	29.93
	14-04-0155		04/08/2014	1515080155 - street lights - 451 Talcott	32.85
	14/04-0229		04/16/2014	0171030229 - street lights - athen knoll	23.41
	14/04-2027		04/18/2014	6235062027 - street lights - rolling mdw dr	4,514.48
Check	04/28/2014	8435 Accounts Payable		Constellation NewEnergy, Inc.	3,177.56
	Invoice		Date	Description	Amount
	0014314990		04/02/2014	1-KYU1OZ - street lights - w/s stephen st 1 N	20.88
	0014341205		04/03/2014	1-KYU1O2 - street lights - ed bossert dr	12.16
	0014341216		04/03/2014	1-KYU1RQ - street lights - 0 stephen st	370.42
	0014296271		04/02/2014	1-KYU1QT - street lights - Lite Rte 25	1,903.83
	0014296244		04/02/2014	1-KYU1PW - street lights - 164 e peiffer ave	142.57
	0014408080		04/07/2014	1-KYU1N5 - street lights - 411 singer ave rear	234.02
	0014408088		04/07/2014	1-KYU1M8 - street lights - 44 stevens st unit lts	64.89
	0014440285		04/09/2014	1-KYU1JH - street lights - 55 stephen st	108.96

Lemont, IL
Warrant list

Bank Account: Clearing - Accounts Payable

Batch Date: 04/28/2014

Type	Date	Number Source	Payee Name	EFT Bank/Account	Transaction Amount
	0014420934		04/09/2014	1-KYU1KE - street lights - 0 N new ave, 101 main st	286.20
	0014420782		04/09/2014	1-KYU1LB - street lights- 47 stevens st	33.63
Check	04/28/2014	8436 Accounts Payable	Courtney's Safety Lane Inc		716.50
	Invoice		Date	Description	Amount
	060204		04/02/2014	safety inspections	105.00
	060216		04/03/2014	safety inspections & supplies	351.50
	060230		04/04/2014	safety inspection	35.00
	060243		04/07/2014	safety inspections	225.00
Check	04/28/2014	8437 Accounts Payable	Crawford, Murphy, Tilly, Inc.		560.00
	Invoice		Date	Description	Amount
	14-04-14		04/14/2014	sewer engineering	560.00
Check	04/28/2014	8438 Accounts Payable	Dustcatchers, Inc.		113.88
	Invoice		Date	Description	Amount
	80088		04/17/2014	2055 - v.h. carpet mat service	45.78
	80090		04/17/2014	2052 - p.d. carpet mat service	68.10
Check	04/28/2014	8439 Accounts Payable	Ehlers & Associates, Inc.		4,500.00
	Invoice		Date	Description	Amount
	347669		12/31/2013	TIF Report and JRB meeting	4,500.00
Check	04/28/2014	8440 Accounts Payable	Elevator Inspection Services		130.00
	Invoice		Date	Description	Amount
	44998		04/10/2014	elevator inspection - police facility	130.00
Check	04/28/2014	8441 Accounts Payable	Emergency Vehicle Technologies		70.85
	Invoice		Date	Description	Amount
	2961		04/08/2014	replacement switch	25.90
	2976		04/11/2014	equipment	44.95
Check	04/28/2014	8442 Accounts Payable	ETP Labs Inc./EnviroTest/Perry Laboratories Inc.		200.00
	Invoice		Date	Description	Amount
	14-130168		04/03/2014	sample testing	200.00
Check	04/28/2014	8443 Accounts Payable	Federal Signal Corp.		6,847.20

Lemont, IL
Warrant list

Bank Account: Clearing - Accounts Payable

Batch Date: 04/28/2014

Type	Date	Number Source	Payee Name	EFT Bank/Account	Transaction Amount	
			Invoice	Date	Description	Amount
			3711139	03/07/2014	siren replacement - equipment	6,847.20
Check	04/28/2014	8444 Accounts Payable	FedEx			61.93
			Invoice	Date	Description	Amount
			2-623-30496	04/16/2014	3612-5837-1 - shipping	61.93
Check	04/28/2014	8445 Accounts Payable	First Communications			1,474.41
			Invoice	Date	Description	Amount
			12345342	04/07/2014	1FC022002003109	1,474.41
Check	04/28/2014	8446 Accounts Payable	Frank Novotny & Associates, Inc.			5,907.50
			Invoice	Date	Description	Amount
			14083-1	04/09/2014	Golf View Estates	76.00
			14147-1	04/09/2014	16548 New Ave rezoning review	203.50
			04151-15	04/09/2014	Krystyna's Crossing subd	818.00
			04271-3	04/09/2014	Old Town Square	608.00
			12387-4	04/09/2014	Kettering subd	836.00
			13165-4	04/09/2014	Timberline Knolls Treatment Ctr utility improvements	118.00
			13237-3	04/09/2014	Birch Path P.U.D. Case 2013-11	304.00
			13284-2	04/09/2014	PAV Property Development	532.00
			13286-3	04/09/2014	Blaze Rugby Complex addition review	380.00
			13357-3	04/09/2014	Franciscan Sisters Admin Bldg addition	532.00
			13423-2	04/09/2014	Jurineck Riskus/Aero Landings recapture	1,272.00
			14020-1	04/09/2014	Kahle Plat of Disconnection-129th & Ashbury	152.00
			13403-1	04/09/2014	Westway Coach project review	76.00
Check	04/28/2014	8447 Accounts Payable	Guaranteed Technical Services And Consulting, Inc.			1,525.46
			Invoice	Date	Description	Amount
			2011796	04/11/2014	I.T. Support	515.00
			2011806	04/19/2014	I.T. Support	1,010.46
Check	04/28/2014	8448 Accounts Payable	Homefield Energy			19,076.23
			Invoice	Date	Description	Amount
			9085314031	04/02/2014	GMCVLG1001 - Mar 2014 electric service	19,076.23

Lemont, IL
Warrant list

Bank Account: Clearing - Accounts Payable

Batch Date: 04/28/2014

Type	Date	Number Source	Payee Name	EFT Bank/Account	Transaction Amount
Check	04/28/2014	8449 Accounts Payable	Homer Industries, LLC		50.00
	Invoice		Date	Description	Amount
		S61836	04/11/2014	dumping fees	50.00
Check	04/28/2014	8450 Accounts Payable	Illinois State Police		283.50
	Invoice		Date	Description	Amount
		14-03-31	01/31/2014	fingerprinting - Cost Center: 1600 ORI: ILL03542S	252.00
		14-03-31 (2)	03/31/2014	fingerprinting - Cost Center:1600 ORI: IL016600L	31.50
Check	04/28/2014	8451 Accounts Payable	Illinois State Police		5,764.00
	Invoice		Date	Description	Amount
		14-05-02	04/10/2014	academy - sheridan, killian	5,764.00
Check	04/28/2014	8452 Accounts Payable	Illinois State Toll Highway Authority		23.20
	Invoice		Date	Description	Amount
		G14574404	04/05/2014	I-Pass	23.20
Check	04/28/2014	8453 Accounts Payable	Illinois State Treasurer		1,947.59
	Invoice		Date	Description	Amount
		106774	03/14/2014	traffic signals	1,947.59
Check	04/28/2014	8454 Accounts Payable	Inkwell, Ltd.		35.99
	Invoice		Date	Description	Amount
		64544	04/09/2014	office supplies	35.99
Check	04/28/2014	8455 Accounts Payable	International Association of Chiefs of Police		240.00
	Invoice		Date	Description	Amount
		2014 (1)	04/10/2014	membership - Gregory D Smith	120.00
		2014 (2)	04/10/2014	membership - Daniel M Tully	120.00
Check	04/28/2014	8456 Accounts Payable	IRMA		1,874.54
	Invoice		Date	Description	Amount
		14-04-23	04/23/2014	refund for damages paid on 03 Dodge Durango	1,874.54
Check	04/28/2014	8457 Accounts Payable	JCM Uniforms		180.00
	Invoice		Date	Description	Amount
		690517	03/17/2014	uniforms	73.90

Lemont, IL
Warrant list

Bank Account: Clearing - Accounts Payable
Batch Date: 04/28/2014

Type	Date	Number Source	Payee Name	EFT Bank/Account	Transaction Amount
		690710	04/02/2014	uniforms	106.10
Check	04/28/2014	8458 Accounts Payable	Johnson, Depp & Quisenberry, PSC		1,703.00
	Invoice		Date	Description	Amount
		14-04-08	04/08/2014	Mar 2014 OAN - annual report	1,703.00
Check	04/28/2014	8459 Accounts Payable	Lemont Ace Hardware		141.04
	Invoice		Date	Description	Amount
		03/31/14	03/31/2014	3542 - Mar 2014 purchases	141.04
Check	04/28/2014	8460 Accounts Payable	Lexis Nexis Risk Data Management		94.50
	Invoice		Date	Description	Amount
		1354915-20140331	03/31/2014	Mar 2014 searches	94.50
Check	04/28/2014	8461 Accounts Payable	Mahoney, Silverman & Cross, LLC		2,035.00
	Invoice		Date	Description	Amount
		40424	04/08/2014	labor legal	2,035.00
Check	04/28/2014	8462 Accounts Payable	Menards		371.17
	Invoice		Date	Description	Amount
		39512	04/03/2014	supplies	371.17
Check	04/28/2014	8463 Accounts Payable	Metropolitan Industries Inc		2,600.00
	Invoice		Date	Description	Amount
		0000283358	03/31/2014	service - lift station	2,600.00
Check	04/28/2014	8464 Accounts Payable	Moeller , Dave		105.15
	Invoice		Date	Description	Amount
		14-03-23	03/23/2014	reimbursement - Speedway - fuel for work at the quarries	105.15
Check	04/28/2014	8465 Accounts Payable	Morris Engineering, Inc.		2,930.00
	Invoice		Date	Description	Amount
		14-04111	04/15/2014	Mar 2014 reviews & inspections	2,930.00
Check	04/28/2014	8466 Accounts Payable	Neopost USA Inc		212.99
	Invoice		Date	Description	Amount
		14250196	04/09/2014	postage meter ink cartridge	161.99

Lemont, IL
Warrant list

Bank Account: Clearing - Accounts Payable
Batch Date: 04/28/2014

Type	Date	Number Source	Payee Name	EFT Bank/Account	Transaction Amount
		9135073	04/10/2014	postage meter repair parts	51.00
Check	04/28/2014	8467 Accounts Payable	New World Systems Corporation		2,240.00
		Invoice	Date	Description	Amount
		034768	03/31/2014	LEM1640-C-14-01-B-01 E-Suite training	2,240.00
Check	04/28/2014	8468 Accounts Payable	NiCor Gas		288.89
		Invoice	Date	Description	Amount
		14/04-2000 6	04/09/2014	69-98-10-2000 6 oak tree l/s	23.10
		14/04-4722 3	04/11/2014	91-25-56-4722 3 eagle ridge l/s	27.46
		14/04-0043 0	04/16/2014	69-22-85-0043 0 ruffled fthrs l/s	78.81
		14/04-1000 5	04/14/2014	84-38-99-1000 5 chestnut crossing l/s	23.10
		14/04-20008	04/14/2014	85-71-20-20008 keepataw trails l/s	23.10
		14/04-9378 5	04/16/2014	25-59-90-9378 5 well #6	89.36
		14/04-2000 8 (2)	04/11/2014	74-12-00-2000 8 harpers grove l/s	23.96
Check	04/28/2014	8469 Accounts Payable	North American Salt Co.		2,071.99
		Invoice	Date	Description	Amount
		71158479	04/15/2014	salt - well #3	2,071.99
Check	04/28/2014	8470 Accounts Payable	O'Brien , Cynthia		100.00
		Invoice	Date	Description	Amount
		201409	04/18/2014	instructor - Watercolor Workshop	100.00
Check	04/28/2014	8471 Accounts Payable	Occupational Health Centers of Illinois. P.C.		107.00
		Invoice	Date	Description	Amount
		1008066846	04/01/2014	employee physical	107.00
Check	04/28/2014	8472 Accounts Payable	OfficeMax Incorporated		74.70
		Invoice	Date	Description	Amount
		147918	04/15/2014	supplies	74.70
Check	04/28/2014	8473 Accounts Payable	PDC Laboratories		467.50
		Invoice	Date	Description	Amount
		765685	03/31/2014	sample testing	467.50
Check	04/28/2014	8474 Accounts Payable	Proven Business Systems, LLC		1,016.26

Lemont, IL
Warrant list

Bank Account: Clearing - Accounts Payable

Batch Date: 04/28/2014

Type	Date	Number Source	Payee Name	EFT Bank/Account	Transaction Amount
	Invoice		Date	Description	Amount
	187300		04/07/2014	Canon copier usage	1,016.26
Check	04/28/2014	8475 Accounts Payable	Quill Corporation		226.55
	Invoice		Date	Description	Amount
	1936841		04/04/2014	office supplies	211.56
	1997863		04/08/2014	office supplies	14.99
Check	04/28/2014	8476 Accounts Payable	Rag's Electric		1,576.60
	Invoice		Date	Description	Amount
	9341		04/07/2014	motion switch repair	468.10
	9355		04/07/2014	Main St L/S repair	108.50
	4827-07		04/01/2014	Lemont Rd bridge light maintenance	1,000.00
Check	04/28/2014	8477 Accounts Payable	Rainbow Printing		291.90
	Invoice		Date	Description	Amount
	410404		04/11/2014	6x9, 9x12 imprinted kraft envelopes	291.90
Check	04/28/2014	8478 Accounts Payable	Raspanti , Robert		23.91
	Invoice		Date	Description	Amount
	14-04-21		04/21/2014	Menards - work gloves	23.91
Check	04/28/2014	8479 Accounts Payable	Ray O'Herron Co., Inc.		3,378.38
	Invoice		Date	Description	Amount
	1420384-IN		04/14/2014	uniforms - killian	1,358.32
	1420386-IN		04/14/2014	uniforms - sheridan	1,372.26
	1421038-IN		04/16/2014	uniform - stella	145.94
	1421042-IN		04/16/2014	uniform - dahlberg	124.98
	1422373-IN		04/21/2014	uniforms - shaughnessy	376.88
Check	04/28/2014	8480 Accounts Payable	Riccio Construction Corp.		5,540.00
	Invoice		Date	Description	Amount
	328		04/12/2014	Talcott parking lot storm sewer improvement	5,540.00
Check	04/28/2014	8481 Accounts Payable	Riley's Trick Shop		265.00
	Invoice		Date	Description	Amount

Lemont, IL
Warrant list

Bank Account: Clearing - Accounts Payable

Batch Date: 04/28/2014

Type	Date	Number Source	Payee Name	EFT Bank/Account	Transaction Amount
	10		04/05/2014	Earth Day buttons	265.00
Check	04/28/2014	8482 Accounts Payable	Rod Baker Ford		204.02
	Invoice		Date	Description	Amount
	127068		04/04/2014	parts	35.99
	127071		04/04/2014	parts	82.67
	127107		04/05/2014	parts	85.36
Check	04/28/2014	8483 Accounts Payable	Ruffled Feathers Golf Club		12,040.51
	Invoice		Date	Description	Amount
	140428F		04/21/2014	Mayor's Drive for Charity Golf Outing - 4/28/14	12,040.51
Check	04/28/2014	8484 Accounts Payable	Safety Kleen		214.53
	Invoice		Date	Description	Amount
	63322885		04/02/2014	parts washer service	214.53
Check	04/28/2014	8485 Accounts Payable	Sikich, LLP		4,887.50
	Invoice		Date	Description	Amount
	179710		04/15/2014	Feb 2014 accounting services	1,667.50
	182993		04/17/2014	Mar 2014 accounting services	3,220.00
Check	04/28/2014	8486 Accounts Payable	Sosin & Arnold, Ltd.		1,000.00
	Invoice		Date	Description	Amount
	84031		03/31/2014	2539.001 adjudication fees	1,000.00
Check	04/28/2014	8487 Accounts Payable	Southwest Central Dispatch		24,811.70
	Invoice		Date	Description	Amount
	14-03-20		03/20/2014	10-1201-513 - Apr 2014 assessment	24,811.70
Check	04/28/2014	8488 Accounts Payable	Standard Equipment Company		96.22
	Invoice		Date	Description	Amount
	C91131		04/01/2014	parts	175.95
	C91132		04/01/2014	parts	99.53
	C91683		04/15/2014	returned items	(179.26)
Check	04/28/2014	8489 Accounts Payable	Standard Insurance Company		1,131.88
	Invoice		Date	Description	Amount

Lemont, IL
Warrant list

Bank Account: Clearing - Accounts Payable

Batch Date: 04/28/2014

Type	Date	Number Source	Payee Name	EFT Bank/Account	Transaction Amount
	14-04-16		04/16/2014	May 2014 short-term disability ins prems	1,131.88
Check	04/28/2014	8490 Accounts Payable	Suburban Law Enforcement Admin Professionals		30.00
	Invoice		Date	Description	Amount
	2014		04/21/2014	annual membership fee - p garcia	30.00
Check	04/28/2014	8491 Accounts Payable	Surefire Auto Parts		225.19
	Invoice		Date	Description	Amount
	14-03-31		03/31/2014	7590 - Mar 2014 purchases	225.19
Check	04/28/2014	8492 Accounts Payable	Swim & Sport Team Outfitters		564.00
	Invoice		Date	Description	Amount
	19845		04/02/2014	uniforms - P.W.	564.00
Check	04/28/2014	8493 Accounts Payable	T.P.I. Building Code Consultants, Inc.		6,585.00
	Invoice		Date	Description	Amount
	7088		03/31/2014	Mar 2014 plan reviews & inspections	6,585.00
Check	04/28/2014	8494 Accounts Payable	Tee Time Lawn Care Inc.		105.00
	Invoice		Date	Description	Amount
	299881		04/08/2014	1396009 - fertilizer application 1	105.00
Check	04/28/2014	8495 Accounts Payable	The Emblem Authority		624.00
	Invoice		Date	Description	Amount
	16137		04/15/2014	caps	624.00
Check	04/28/2014	8496 Accounts Payable	Tifco Industries		78.51
	Invoice		Date	Description	Amount
	70939852		04/02/2014	supplies	78.51
Check	04/28/2014	8497 Accounts Payable	Tressler, LLP		29,811.20
	Invoice		Date	Description	Amount
	338591/338595		03/20/2014	Feb 2014 legal fees	14,702.60
	339565/572/573		03/31/2014	Mar 2014 legal fees	15,045.60
	335090/096/097b		04/22/2014	bal due - Dec 2013	63.00
Check	04/28/2014	8498 Accounts Payable	Unifirst Corporation		49.02

Lemont, IL
Warrant list

Bank Account: Clearing - Accounts Payable
 Batch Date: 04/28/2014

Type	Date	Number Source	Payee Name	EFT Bank/Account	Transaction Amount
	Invoice		Date	Description	Amount
	062 0070797		04/07/2014	shop towel service	49.02
Check	04/28/2014	8499 Accounts Payable	Verizon Wireless		113.47
	Invoice		Date	Description	Amount
	9722902392		04/03/2014	685282853-00001	113.47
Check	04/28/2014	8500 Accounts Payable	Vulcan Materials		519.91
	Invoice		Date	Description	Amount
	30575297		04/08/2014	gravel	519.91
Check	04/28/2014	8501 Accounts Payable	Warehouse Direct Workplace Solutions		441.14
	Invoice		Date	Description	Amount
	2283229-0		04/07/2014	supplies	82.68
	2284448-0		04/08/2014	supplies	162.73
	2294105-0		04/17/2014	supplies	195.73
Check	04/28/2014	8502 Accounts Payable	Water Products Company of Aurora, Inc.		547.75
	Invoice		Date	Description	Amount
	0247491		04/04/2014	hydrant tool	145.00
	0247492		04/04/2014	hydrant repair parts	402.75
Check	04/28/2014	8503 Accounts Payable	Water Resources Inc.		8,599.67
	Invoice		Date	Description	Amount
	28581		04/09/2014	meter reading unit	6,300.00
	28606		04/02/2014	meter reader repair	533.84
	28612		04/03/2014	meters	1,765.83
Check	04/28/2014	8504 Accounts Payable	West Side Tractor Sales		395.35
	Invoice		Date	Description	Amount
	N00673		04/04/2014	parts	395.35
Check	04/28/2014	8505 Accounts Payable	Wolfe , John		869.00
	Invoice		Date	Description	Amount
	293881		04/17/2014	parts for shop press	707.93
	289816		01/29/2014	tool	161.07

Lemont, IL
Warrant list

Bank Account: Clearing - Accounts Payable
Batch Date: 04/28/2014

Type	Date	Number Source	Payee Name	EFT Bank/Account	Transaction Amount
Check	04/28/2014	8506 Accounts Payable	Superior Corporation		1,000.00
	Invoice		Date	Description	Amount
	2014-00000036		04/10/2014	clean up bond refund -12797 Tullamore Ln	1,000.00
Clearing Accounts Payable Totals:			Transactions: 93		<u>\$206,841.43</u>
	Checks:	93	\$206,841.43		

Lemont, IL
Warrant list

Bank Account: GMAT Project - GMAT Project

Batch Date: 04/24/2014

Type	Date	Number Source	Payee Name	EFT Bank/Account	Transaction Amount
Bank Account: GMAT Project - GMAT Project					
Check	04/24/2014	15119 Accounts Payable	Hatcher , Bessie		125.00
	Invoice		Date	Description	Amount
	14-04-01		04/01/2014	Battle office cleaning	62.50
	14-04-08		04/08/2014	Battle office cleaning	62.50
GMAT Project GMAT Project Totals:			Transactions: 1		<u>\$125.00</u>
Checks:		1	\$125.00		

Lemont, IL
Warrant list

Bank Account: GMAT Grant - GMAT Grant

Batch Date: 04/24/2014

Type	Date	Number Source	Payee Name	EFT Bank/Account	Transaction Amount
Bank Account: GMAT Grant - GMAT Grant					
Check	04/24/2014	10676 Accounts Payable	AT&T Illinois		364.24
	Invoice	Date	Description		Amount
		630Z9928210314	03/16/2014	630 Z99-2821 948 3	364.24
Check	04/24/2014	10677 Accounts Payable	Battle/Greater Metropolitan Auto Theft		2,919.26
	Invoice	Date	Description		Amount
		14-04-03	04/03/2014	reimbursement	2,919.26
Check	04/24/2014	10678 Accounts Payable	Canon Financial Services, Inc.		61.05
	Invoice	Date	Description		Amount
		13612083	03/13/2014	L16081	61.05
Check	04/24/2014	10679 Accounts Payable	DuPage County Sheriff		8,500.00
	Invoice	Date	Description		Amount
		14-04-01	04/01/2014	1st qtr salary reimbursement - Leonard	8,500.00
Check	04/24/2014	10680 Accounts Payable	DuPage County States Attorney		21,240.00
	Invoice	Date	Description		Amount
		14-03-31	04/01/2014	1st qtr salary reimbursement	21,240.00
Check	04/24/2014	10681 Accounts Payable	Elk Grove Village P.D.		21,957.00
	Invoice	Date	Description		Amount
		14-03-31	03/31/2014	1st qtr salary reimbursement - Froehlich	21,957.00
Check	04/24/2014	10682 Accounts Payable	Floudas Automotive		45.20
	Invoice	Date	Description		Amount
		34314	03/25/2014	Buick Enclave maintenance	45.20
Check	04/24/2014	10683 Accounts Payable	Ice Mountain		80.14
	Invoice	Date	Description		Amount
		04C0119236503	03/12/2014	water delivery	80.14
Check	04/24/2014	10684 Accounts Payable	Illinois Department of Central Management Services		279.12
	Invoice	Date	Description		Amount
		T428477	03/17/2014	T8889174 - Feb 2014 comm svcs	279.12

Lemont, IL
Warrant list

Bank Account: GMAT Grant - GMAT Grant
 Batch Date: 04/24/2014

Type	Date	Number Source	Payee Name	EFT Bank/Account	Transaction Amount
Check	04/24/2014	10685 Accounts Payable	Kane County State's Attorney's Office		1,417.00
	Invoice		Date	Description	Amount
	14-02-28		03/18/2014	Feb 2014 salary reimbursement - Sams	1,417.00
Check	04/24/2014	10686 Accounts Payable	Menards		138.23
	Invoice		Date	Description	Amount
	39455		03/27/2014	supplies	134.25
	40425		04/24/2014	supplies	3.98
Check	04/24/2014	10687 Accounts Payable	Office Depot		711.83
	Invoice		Date	Description	Amount
	1665938420		03/13/2014	42041316	711.83
Check	04/24/2014	10688 Accounts Payable	P. F. Pettibone & Co.		57.70
	Invoice		Date	Description	Amount
	30145		03/05/2014	neck chains	57.70
Check	04/24/2014	10689 Accounts Payable	Quill Corporation		123.34
	Invoice		Date	Description	Amount
	65227746		03/18/2014	C2135669 - office supplies	23.39
	65344279		03/14/2014	C2135669 - office supplies	99.95
Check	04/24/2014	10690 Accounts Payable	Schroeder , Virgil		10.76
	Invoice		Date	Description	Amount
	14-04-03		04/04/2014	Walmart purchase - wiper blades for Impala	10.76
GMAT Grant GMAT Grant Totals:			Transactions: 15		\$57,904.87
Checks:	15	\$57,904.87			

Lemont, IL
Warrant list

Bank Account: Clearing - Accounts Payable

Batch Date: 05/12/2014

Type	Date	Number Source	Payee Name	EFT Bank/Account	Transaction Amount
Bank Account: Clearing - Accounts Payable					
Check	05/12/2014	8509 Accounts Payable	Air 1 Wireless, Inc		49.95
	Invoice	Date	Description		Amount
		AIR1OIN8692	04/11/2014	cell phone case	49.95
Check	05/12/2014	8510 Accounts Payable	Alexander Chemical Corp		1,665.00
	Invoice	Date	Description		Amount
		SLS 10017578	04/25/2014	chlorine	2,765.00
		SCL 10004562	04/29/2014	deposit refund - 14 used 150lb chlorine cylinders	(1,100.00)
Check	05/12/2014	8511 Accounts Payable	Amalgamated Bank of Chicago		10,042.50
	Invoice	Date	Description		Amount
		14-06-01 2355	06/01/2014	Series 2004 BI #2355	10,042.50
Check	05/12/2014	8512 Accounts Payable	Amalgamated Bank of Chicago		176,131.25
	Invoice	Date	Description		Amount
		14-06-01 4427	06/01/2014	Series 2010 BI #4427	176,131.25
Check	05/12/2014	8513 Accounts Payable	Amalgamated Bank of Chicago		39,102.50
	Invoice	Date	Description		Amount
		14-06-01 4984	06/01/2014	Series 2012C BI #4984	39,102.50
Check	05/12/2014	8514 Accounts Payable	Amalgamated Bank of Chicago		7,780.00
	Invoice	Date	Description		Amount
		14-06-01 2386	06/01/2014	Series 2005 BI #2386	7,780.00
Check	05/12/2014	8515 Accounts Payable	Amalgamated Bank of Chicago		21,383.75
	Invoice	Date	Description		Amount
		14-06-01 2387	06/01/2014	Series 2005 BI #2387	21,383.75
Check	05/12/2014	8516 Accounts Payable	Amalgamated Bank of Chicago		16,335.00
	Invoice	Date	Description		Amount
		14-06-01 2438	06/01/2014	Series 2005 BI #2438	16,335.00
Check	05/12/2014	8517 Accounts Payable	Amalgamated Bank of Chicago		48,512.50
	Invoice	Date	Description		Amount

Lemont, IL
Warrant list

Bank Account: Clearing - Accounts Payable
Batch Date: 05/12/2014

Type	Date	Number Source	Payee Name	EFT Bank/Account	Transaction Amount
	14-06-01	2914	06/01/2014	Series 2007 BI #2914	48,512.50
Check	05/12/2014	8518 Accounts Payable	Amalgamated Bank of Chicago		139,480.00
	Invoice		Date	Description	Amount
	14-06-01	3079	06/01/2014	Series 2007A BI #3079	139,480.00
Check	05/12/2014	8519 Accounts Payable	Amalgamated Bank of Chicago		33,805.00
	Invoice		Date	Description	Amount
	14-06-01	3109	06/01/2014	Series 2008 BI #3109	33,805.00
Check	05/12/2014	8520 Accounts Payable	Amalgamated Bank of Chicago		31,843.75
	Invoice		Date	Description	Amount
	14-06-01	3373	06/01/2014	Series 2009 BI #3373	31,843.75
Check	05/12/2014	8521 Accounts Payable	Amalgamated Bank of Chicago		33,751.25
	Invoice		Date	Description	Amount
	14-06-01	4131	06/01/2014	Series 2010 BI #4131	33,751.25
Check	05/12/2014	8522 Accounts Payable	Applied Ecological Services, Inc.		10,474.80
	Invoice		Date	Description	Amount
	28092		03/31/2014	10-0381 Long Run Creek	10,474.80
Check	05/12/2014	8523 Accounts Payable	AT&T Illinois		735.85
	Invoice		Date	Description	Amount
	63025722900414		04/30/2014	630 257-2290 820 6 well #3	126.31
	63025752720414		04/30/2014	630 257-5272 181 8 metra station	82.43
	63025704360414		04/30/2014	630 257-0436 056 6 glens of connemara l/s	69.43
	63025719820414		04/30/2014	630 257-1982 589 2 ruffled fthrs l/s	66.98
	63025795390414		04/30/2014	630 257-9539 074 6 keepataw trails l/s	70.63
	63025752710414		04/30/2014	630 257-5271 183 5 harpers grove l/s	67.14
	63025759360414		04/30/2014	630 257-5936 976 9 well #4	71.12
	63025724740414		04/25/2014	630 257-2474 474 0 p.d. phone line	181.81
Check	05/12/2014	8524 Accounts Payable	Avalon Petroleum Company		7,308.00
	Invoice		Date	Description	Amount
	552241		04/18/2014	2100 gals unl fuel	7,308.00
Check	05/12/2014	8525 Accounts Payable	Avaya Inc.		360.42

Lemont, IL
Warrant list

Bank Account: Clearing - Accounts Payable

Batch Date: 05/12/2014

Type	Date	Number Source	Payee Name	EFT Bank/Account	Transaction Amount
	Invoice		Date	Description	Amount
	2733071062		04/26/2014	Phone system for PD - 1st lease pmt	360.42
Check	05/12/2014	8526 Accounts Payable	Azavar Audit Solutions		2,252.95
	Invoice		Date	Description	Amount
	10109		05/01/2014	May 2014 utility audit contingency pmt	2,252.95
Check	05/12/2014	8527 Accounts Payable	Battery Service Corp.		189.85
	Invoice		Date	Description	Amount
	245275		04/16/2014	parts	100.35
	245389		04/17/2014	battery	89.50
Check	05/12/2014	8528 Accounts Payable	Beaver Creek Enterprises, Inc.		382.83
	Invoice		Date	Description	Amount
	26846		04/21/2014	parts	313.26
	26853		04/22/2014	parts	69.57
Check	05/12/2014	8529 Accounts Payable	Bristol Hose & Fitting		91.00
	Invoice		Date	Description	Amount
	00349824		04/24/2014	parts	91.00
Check	05/12/2014	8530 Accounts Payable	Burris Equipment Co.		419.74
	Invoice		Date	Description	Amount
	PS84817		04/29/2014	parts	419.74
Check	05/12/2014	8531 Accounts Payable	C.E.S. (City Electric Supply Co-MA)		356.20
	Invoice		Date	Description	Amount
	ROM/022273		04/07/2014	street light parts	356.20
Check	05/12/2014	8532 Accounts Payable	Car Reflections		860.00
	Invoice		Date	Description	Amount
	14-229		04/29/2014	vehicle striping	860.00
Check	05/12/2014	8533 Accounts Payable	Card Imaging		5,539.25
	Invoice		Date	Description	Amount
	89364		04/02/2014	ID card equipment	5,539.25
Check	05/12/2014	8534 Accounts Payable	Carey C. Cosentino, PC		2,000.00

Lemont, IL
Warrant list

Bank Account: Clearing - Accounts Payable

Batch Date: 05/12/2014

Type	Date	Number Source	Payee Name	EFT Bank/Account	Transaction Amount
	Invoice		Date	Description	Amount
	14-05-01		05/01/2014	April 2014 legal	2,000.00
Check	05/12/2014	8535 Accounts Payable	CDW Government, LLC		192.07
	Invoice		Date	Description	Amount
	LK73372		04/24/2014	printer	192.07
Check	05/12/2014	8536 Accounts Payable	Chicago Badge & Insignia Co.		127.21
	Invoice		Date	Description	Amount
	12854		04/26/2014	badge - M Cagle	59.41
	12846		04/26/2014	badge - M Cagle	67.80
Check	05/12/2014	8537 Accounts Payable	Chipain's Finer Foods		71.49
	Invoice		Date	Description	Amount
	14-05-24		05/04/2014	0066 - Apr 2014 purchases - kitchen supplies	71.49
Check	05/12/2014	8538 Accounts Payable	Comcast Cable		206.20
	Invoice		Date	Description	Amount
	14-04-8896		04/22/2014	8771 20 147 0138896 p.w. cable/internet	206.20
Check	05/12/2014	8539 Accounts Payable	ComEd		242.78
	Invoice		Date	Description	Amount
	14/04-8014		04/29/2014	3909078014 - street lights - illinois, e of stephen	20.07
	14/04-0007		04/29/2014	1173160007 - street lights - talcott, e of stephen	152.83
	14/04-4052		04/29/2014	2163104052 - street lights - stephen st 1 S river	69.88
Check	05/12/2014	8540 Accounts Payable	De Lage Landen Public Finance		602.00
	Invoice		Date	Description	Amount
	41188449		04/28/2014	629642 - Canon copier leases - May-Jun	602.00
Check	05/12/2014	8541 Accounts Payable	Dustcatchers, Inc.		38.88
	Invoice		Date	Description	Amount
	80835		05/01/2014	2055 - v.h. carpet mat service	38.88
Check	05/12/2014	8542 Accounts Payable	Emergency Vehicle Technologies		3,300.00
	Invoice		Date	Description	Amount
	2989		04/22/2014	remove & install new SWCD computers	3,300.00

Lemont, IL
Warrant list

Bank Account: Clearing - Accounts Payable

Batch Date: 05/12/2014

Type	Date	Number Source	Payee Name	EFT Bank/Account	Transaction Amount
Check	05/12/2014	8543 Accounts Payable	Fastenal Company		414.02
	Invoice		Date	Description	Amount
		ILROM43060	04/15/2014	parts	329.56
		ILROM43187	04/21/2014	parts	84.46
Check	05/12/2014	8544 Accounts Payable	FedEx		26.90
	Invoice		Date	Description	Amount
		2-631-01868	04/23/2014	shipping	26.90
Check	05/12/2014	8545 Accounts Payable	Fleet Safety Supply		76.12
	Invoice		Date	Description	Amount
		60127	04/18/2014	flashing light	76.12
Check	05/12/2014	8546 Accounts Payable	Frank Novotny & Associates, Inc.		21,139.48
	Invoice		Date	Description	Amount
		06028.GE-37	04/09/2014	general engineering services	912.00
		05382-20	04/09/2014	Glens of Connemara subd	2,530.00
		13040-3	04/09/2014	Gateway TIF	2,481.50
		13047-2	04/09/2014	Plat of annexation/10970 Archer Ave (Gateway TIF)	304.00
		13083-4	04/09/2014	Division St water main loop	796.50
		13142-3	04/09/2014	MWRDGC lease parcel surveys	7,875.00
		13186-4	04/09/2014	Bell Rd and First Church of the Nazarene utility extension	1,320.75
		02115-50	04/09/2014	NPDES-Phase 2 CSO Flow Monitoring	1,318.98
		13347-2	04/09/2014	Archer Ave @ 135th St IDOT improvements	1,140.00
		14034-1	04/09/2014	Archer Ave/Old Bell Rd/Rt 83/Main St (Gateway TIF)	228.00
		14061-1	04/09/2014	IMTT Emergency Water Supply meeting	228.00
		14078-1	04/09/2014	IMTT culvert replacement	912.00
		14088-1	04/09/2014	Cook Co Hazard Mitigation Survey	228.00
		14113-1	04/09/2014	Bell Rd ComEd easement #4	28.75
		14145-1	04/09/2014	MWRDGC O & M report	228.00
		14149-1	04/09/2014	I & M Canal wall repair	304.00
		13358-2	04/09/2014	2014 Capital Projects budget estimates	304.00
Check	05/12/2014	8547 Accounts Payable	G2 Consulting Group, LLC		2,100.00
	Invoice		Date	Description	Amount

Lemont, IL
Warrant list

Bank Account: Clearing - Accounts Payable
Batch Date: 05/12/2014

Type	Date	Number Source	Payee Name	EFT Bank/Account	Transaction Amount
		140639	04/23/2014	environmental consult - 10980 Archer	2,100.00
Check	05/12/2014	8548 Accounts Payable	Guaranteed Technical Services And Consulting, Inc.		640.00
		Invoice	Date	Description	Amount
		2011841	04/25/2014	I.T. Support	640.00
Check	05/12/2014	8549 Accounts Payable	Homer Industries, LLC		1,045.00
		Invoice	Date	Description	Amount
		S62372	04/22/2014	mulch	247.00
		S62472	04/23/2014	mulch	266.00
		S62576	04/24/2014	mulch	266.00
		S62707	04/25/2014	mulch	266.00
Check	05/12/2014	8550 Accounts Payable	Hoppy's Landscaping		3,138.47
		Invoice	Date	Description	Amount
		6587	02/12/2014	road salt	3,138.47
Check	05/12/2014	8551 Accounts Payable	Illinois Department of Agriculture		75.00
		Invoice	Date	Description	Amount
		14-05-01	05/01/2014	pest control licenses	75.00
Check	05/12/2014	8552 Accounts Payable	Illinois Municipal League		1,238.00
		Invoice	Date	Description	Amount
		14-06-01	04/21/2014	membership dues	1,238.00
Check	05/12/2014	8553 Accounts Payable	Illinois Secretary Of State		10.00
		Invoice	Date	Description	Amount
		14-04-17	04/17/2014	DL suspension fee 1844381	10.00
Check	05/12/2014	8554 Accounts Payable	Illinois State Treasurer		2,693.70
		Invoice	Date	Description	Amount
		41333	04/15/2014	25528 - traffic signal maintenance	2,693.70
Check	05/12/2014	8555 Accounts Payable	Imperial Service Systems Inc		1,009.00
		Invoice	Date	Description	Amount
		75592	05/01/2014	May 2014 monthly cleaning service	1,009.00

Lemont, IL
Warrant list

Bank Account: Clearing - Accounts Payable

Batch Date: 05/12/2014

Type	Date	Number Source	Payee Name	EFT Bank/Account	Transaction Amount
Check	05/12/2014	8556 Accounts Payable	Inkwell, Ltd.		94.49
	Invoice		Date	Description	Amount
		64758	04/30/2014	office supplies	94.49
Check	05/12/2014	8557 Accounts Payable	IPELRA		475.00
	Invoice		Date	Description	Amount
		14-05-15	04/24/2014	supervisory training	475.00
Check	05/12/2014	8558 Accounts Payable	Jones , Charity		106.15
	Invoice		Date	Description	Amount
		14-04-24	04/24/2014	reimbursement	106.15
Check	05/12/2014	8559 Accounts Payable	Lemont Ace Hardware		2,533.13
	Invoice		Date	Description	Amount
		14-04-30	04/30/2014	3960 - Apr 2014 purchases (incl 50 Weed & Feed)	2,533.13
Check	05/12/2014	8560 Accounts Payable	Lina Embroidery		4,457.50
	Invoice		Date	Description	Amount
		S12324	04/10/2014	Quarryman Challenge t-shirts	4,457.50
Check	05/12/2014	8561 Accounts Payable	Macke Water Systems, Inc.		114.32
	Invoice		Date	Description	Amount
		919105	05/01/2014	146998 - coffee service supplies	114.32
Check	05/12/2014	8562 Accounts Payable	Menards		84.38
	Invoice		Date	Description	Amount
		40291	04/17/2014	maintenance supplies	24.40
		40650	04/23/2014	tools	59.98
Check	05/12/2014	8563 Accounts Payable	Metropolitan Industries Inc		828.00
	Invoice		Date	Description	Amount
		0000284328	04/25/2014	Smith Farms lift station	828.00
Check	05/12/2014	8564 Accounts Payable	Molitor , Linda		613.20
	Invoice		Date	Description	Amount
		14-05-05	05/05/2014	reimbursement	613.20
Check	05/12/2014	8565 Accounts Payable	Morris Engineering, Inc.		400.00

Lemont, IL
Warrant list

Bank Account: Clearing - Accounts Payable
 Batch Date: 05/12/2014

Type	Date	Number Source	Payee Name	EFT Bank/Account	Transaction Amount	
			Invoice	Date	Description	Amount
			14-04137	04/29/2014	Main St retaining wall monitoring	400.00
Check	05/12/2014	8566 Accounts Payable	Napa Auto Parts			357.36
			Invoice	Date	Description	Amount
			074233	04/16/2014	parts	208.36
			079590	04/24/2014	parts subscription service	149.00
Check	05/12/2014	8567 Accounts Payable	New World Systems Corporation			900.00
			Invoice	Date	Description	Amount
			035043	04/17/2014	LEM1640-N-14-01-M-01 Notes List for Permits modification	900.00
Check	05/12/2014	8568 Accounts Payable	NiCor Gas			48.36
			Invoice	Date	Description	Amount
			14/04-87001	04/21/2014	93-56-54-8700 1 smith farms l/s	25.04
			14/04-9589 2	04/22/2014	37-62-87-9589 2 target-kohls l/s	23.32
Check	05/12/2014	8569 Accounts Payable	North American Salt Co.			2,164.85
			Invoice	Date	Description	Amount
			71158967	04/16/2014	salt - well 4	2,164.85
Check	05/12/2014	8570 Accounts Payable	P. F. Pettibone & Co.			149.05
			Invoice	Date	Description	Amount
			30586	04/29/2014	RP-2000 file sticker printing	149.05
Check	05/12/2014	8571 Accounts Payable	P. T. Ferro Construction Co.			19,116.69
			Invoice	Date	Description	Amount
			43854	04/21/2014	Derby Rd guardrail repair	2,025.00
			63557	04/29/2014	IDOT contract - triangle project	17,091.69
Check	05/12/2014	8572 Accounts Payable	Pelen , Laura			5,850.00
			Invoice	Date	Description	Amount
			VOL 2014-102	04/28/2014	consulting	5,850.00
Check	05/12/2014	8573 Accounts Payable	Rag's Electric			413.28
			Invoice	Date	Description	Amount
			9371	04/14/2014	light parts	413.28

Lemont, IL
Warrant list

Bank Account: Clearing - Accounts Payable

Batch Date: 05/12/2014

Type	Date	Number Source	Payee Name	EFT Bank/Account	Transaction Amount
Check	05/12/2014	8574 Accounts Payable	Rainbow Printing		1,085.95
	Invoice		Date	Description	Amount
		410415	04/18/2014	#10 utility bill envelopes	175.95
		410423	04/25/2014	Mayor's Drive sponsor sign	135.00
		410441	05/01/2014	OAN report booklets	775.00
Check	05/12/2014	8575 Accounts Payable	Reed's Automotive Enterprises		425.00
	Invoice		Date	Description	Amount
		14-04-29	04/29/2014	hood replacement	425.00
Check	05/12/2014	8576 Accounts Payable	Romanowski , Paul		125.00
	Invoice		Date	Description	Amount
		4282014	04/28/2014	website maintenance	125.00
Check	05/12/2014	8577 Accounts Payable	Schomig Land Surveyors, Ltd		2,000.00
	Invoice		Date	Description	Amount
		8949-20	04/01/2014	Talcot lot survey	2,000.00
Check	05/12/2014	8578 Accounts Payable	ServiceMaster By Bouck		2,671.00
	Invoice		Date	Description	Amount
		A761954	05/01/2014	May 2014 janitorial service	2,671.00
Check	05/12/2014	8579 Accounts Payable	South Suburban Association of Chiefs of Police		50.00
	Invoice		Date	Description	Amount
		2014 (3)	05/01/2014	annual membership dues renewal - D Tully	50.00
Check	05/12/2014	8580 Accounts Payable	Southwest Central Dispatch		25,431.99
	Invoice		Date	Description	Amount
		14-04-20	04/20/2014	10-1201-513 - May 2014 assessment	25,431.99
Check	05/12/2014	8581 Accounts Payable	Southwest Digital Printing, Inc.		24.67
	Invoice		Date	Description	Amount
		4-650mr	04/22/2014	plotter usage	24.67
Check	05/12/2014	8582 Accounts Payable	Surefire Auto Parts		534.78
	Invoice		Date	Description	Amount

Lemont, IL
Warrant list

Bank Account: Clearing - Accounts Payable

Batch Date: 05/12/2014

Type	Date	Number Source	Payee Name	EFT Bank/Account	Transaction Amount
		347284	04/04/2014	parts	15.30
		348348	04/11/2014	parts	23.12
		348748	04/14/2014	parts	41.13
		349008	04/15/2014	parts	5.99
		349466	04/18/2014	parts	17.70
		351078	04/29/2014	parts	371.84
		351279	04/30/2014	parts	52.29
		351343	04/30/2014	parts	7.41
Check	05/12/2014	8583 Accounts Payable		Tee Jay Service Company	953.00
	Invoice		Date	Description	Amount
		118929	04/22/2014	building maintenance	953.00
Check	05/12/2014	8584 Accounts Payable		TigerDirect, Inc.	1,239.35
	Invoice		Date	Description	Amount
		J66253320101	02/10/2014	computer	921.80
		J66147160105	02/06/2014	monitors	237.28
		J66147160102	02/12/2014	computer warranty	80.27
Check	05/12/2014	8585 Accounts Payable		Total Parking Solutions Inc.	304.00
	Invoice		Date	Description	Amount
		102555	04/22/2014	receipt printer paper	304.00
Check	05/12/2014	8586 Accounts Payable		Tressler, LLP	2,420.90
	Invoice		Date	Description	Amount
		339565/572/573b	04/30/2014	bal due - Mar 14	2,420.90
Check	05/12/2014	8587 Accounts Payable		Vision Service Plan	1,166.56
	Invoice		Date	Description	Amount
		14-04-17	04/17/2014	May 2014 vision benefits	1,166.56
Check	05/12/2014	8588 Accounts Payable		Warehouse Direct Workplace Solutions	174.02
	Invoice		Date	Description	Amount
		2291939-0	04/15/2014	office supplies	174.02
Check	05/12/2014	8589 Accounts Payable		Water Products Company of Aurora, Inc.	915.40
	Invoice		Date	Description	Amount

Lemont, IL
Warrant list

Bank Account: Clearing - Accounts Payable
 Batch Date: 05/12/2014

Type	Date	Number Source	Payee Name	EFT Bank/Account	Transaction Amount
	0248032		04/24/2014	hydrant repair parts	915.40
Check	05/12/2014	8590 Accounts Payable	Wentworth Tire Service, Inc.		645.80
	Invoice		Date	Description	Amount
	432648		04/29/2014	parts	322.90
	432705		05/01/2014	parts	322.90
Check	05/12/2014	8591 Accounts Payable	WEX Fleet Universal		729.70
	Invoice		Date	Description	Amount
	36615880		04/30/2014	Apr 2014 retail fuel purchases	729.70
Check	05/12/2014	8592 Accounts Payable	Zee Medical Inc.		478.71
	Invoice		Date	Description	Amount
	0100142907		04/11/2014	first aid supplies	26.98
	0100183022		04/28/2014	safety supplies	107.88
	0100183004		04/24/2014	safety supplies	343.85
Check	05/12/2014	8593 Accounts Payable	410 Main St Property		217.02
	Invoice		Date	Description	Amount
	14-03-31		03/31/2014	escrow refund - Case # 2014-01	217.02
Check	05/12/2014	8594 Accounts Payable	Dabney , Doreen		48.02
	Invoice		Date	Description	Amount
	14-04-25		04/30/2014	Dunkin Donuts coffee for Recycle event volunteers/police	48.02
Clearing Accounts Payable Totals:			Transactions: 86		\$709,586.29
	Checks:	86		\$709,586.29	

Lemont, IL
Warrant list

Bank Account: Clearing - Accounts Payable
 Batch Date: 05/06/2014

Type	Date	Number Source	Payee Name	EFT Bank/Account	Transaction Amount
Bank Account: Clearing - Accounts Payable					
Check	05/06/2014	8507 Accounts Payable	IRMA		125.00
	Invoice		Date	Description	Amount
	14-05-06		05/06/2014	5/10/14 Quarryman Challenge race liquor liability insurance	125.00
Check	05/06/2014	8508 Accounts Payable	Petty Cash		2,000.00
	Invoice		Date	Description	Amount
	14-05-06		05/06/2014	5/10/14 Quarryman Challenge Race prize money	2,000.00
Clearing Accounts Payable Totals:			Transactions: 2		\$2,125.00
Checks:		2	\$2,125.00		

Payment Register

From Payment Date: 4/1/2014 - To Payment Date: 5/9/2014

Number	Date	Status	Void Reason	Reconciled/ Voided Date	Source	Payee Name	Transaction Amount	Reconciled Amount	Difference
Clearing - Accounts Payable									
<u>EFT</u>									
23	04/23/2014	Open			Accounts Payable	Southwest Agency for Health Management	\$83,551.36		
24	04/28/2014	Open			Accounts Payable	Chase Cardmember Service	\$6,982.83		
25	04/30/2014	Open			Accounts Payable	Illinois Municipal Retirement Fund	\$35,722.79		
Type EFT Totals:									
Clearing - Accounts Payable Totals								\$126,256.98	

EFTs	Status	Count	Transaction Amount	Reconciled Amount
	Open	3	\$126,256.98	\$0.00
	Reconciled	0	\$0.00	\$0.00
	Voided	0	\$0.00	\$0.00
	Total	3	\$126,256.98	\$0.00

All	Status	Count	Transaction Amount	Reconciled Amount
	Open	3	\$126,256.98	\$0.00
	Reconciled	0	\$0.00	\$0.00
	Voided	0	\$0.00	\$0.00
	Stopped	0	\$0.00	\$0.00
	Total	3	\$126,256.98	\$0.00

Grand Totals:

EFTs	Status	Count	Transaction Amount	Reconciled Amount
	Open	3	\$126,256.98	\$0.00
	Reconciled	0	\$0.00	\$0.00
	Voided	0	\$0.00	\$0.00
	Total	3	\$126,256.98	\$0.00

All	Status	Count	Transaction Amount	Reconciled Amount
	Open	3	\$126,256.98	\$0.00
	Reconciled	0	\$0.00	\$0.00
	Voided	0	\$0.00	\$0.00
	Stopped	0	\$0.00	\$0.00
	Total	3	\$126,256.98	\$0.00

**Village Board
Agenda Memorandum**

To: Mayor & Village Board

From: Chief Kevin W. Shaughnessy

Date: April 18, 2014

Re: **Parking Restrictions on East side of Eagle Crest, Adjacent to
Centennial Pool**

BACKGROUND/HISTORY

Last year we temporarily restricted parking on the East side of Eagle Crest and it was very successful. The Police Department is recommending this change become permanent from May 1st – October 1st.

PROS/CONS/ALTERNATIVES (IF APPLICABLE)

RECOMMENDATIONS

Restrict parking on Eagle Crest adjacent to Centennial Pool on East side of Eagle Crest.

ATTACHMENTS

Ordinance

SPECIFIC VILLAGE BOARD ACTION REQUIRED

Ordinance Approval

**VILLAGE OF LEMONT
ORDINANCE NO. _____**

**An Ordinance Amending Title 10 of the Lemont, Illinois
Municipal Code Relating to Parking**

**ADOPTED BY THE
PRESIDENT AND THE BOARD OF TRUSTEES
OF THE VILLAGE OF LEMONT
THIS 12th DAY OF MAY, 2014**

**Published in pamphlet form by
Authority of the President and
Board of Trustees of the Village of
Lemont, Counties of Cook, Will and
DuPage, Illinois, this 12th day of May, 2014.**

ORDINANCE NO. _____

**An Ordinance Amending Title 10 of the Lemont, Illinois
Municipal Code Relating to Parking**

WHEREAS, the Village of Lemont (“Village”) is an Illinois Municipal Corporation pursuant to the Illinois Constitution of 1970 and the Statutes of the State of Illinois; and

WHEREAS, the Village has in the past restricted parking along Eagle Crest Drive adjacent to the Centennial Outdoor Aquatic Center on a temporary basis; and

WHEREAS, the Village has determined that it is necessary and in the best interests of the public health, safety and welfare to implement permanent parking restrictions along Eagle Crest Drive and to make certain other changes to the parking restrictions in the Village; and

WHEREAS, the Village President and Board of Trustees desire to amend Sections 10.16.050 and 10.16.061 of the Lemont, Illinois Municipal Code (“Village Code”) to reflect these changes in the manner set forth below.

NOW, THEREFORE, BE IT ORDAINED BY THE PRESIDENT and BOARD OF TRUSTEES OF THE VILLAGE OF LEMONT, COOK, DUPAGE AND WILL COUNTIES, ILLINOIS, as follows:

SECTION 1: The statements set forth in the preamble to this Ordinance are found to be true and correct and are incorporated into this Ordinance as if set forth in full.

SECTION 2: The Village Code, as amended, is hereby further amended in Title 10, VEHICLES AND TRAFFIC, by amending Section 10.16.050 No Parking Areas Designated, by striking subparagraph (9) in its entirety and replacing it with a new subparagraph (9) so that the same shall be read as follows:

- (9) Eagle Crest Drive, eastside, from W. 127th Street to W. Deer Lane, from May 1st through and including October 1st of each calendar year.

SECTION 3: The Village Code, as amended, is hereby further amended in Title 10, VEHICLES AND TRAFFIC, by striking Section 10.16.061 Resident Parking in its entirety.

SECTION 4: Appropriate signs shall be erected informing the public that parking is prohibited as provided herein.

SECTION 5: The Village Clerk of the Village of Lemont be and is directed hereby to publish this Ordinance in pamphlet form, pursuant to the Statutes of the State of Illinois, made and provided.

SECTION 6: This Ordinance shall be in full force and effect from and after its passage, approval, and publication as provided by law.

PASSED AND APPROVED BY THE PRESIDENT AND BOARD OF TRUSTEES OF THE VILLAGE OF LEMONT, COUNTIES OF COOK, WILL, AND DUPAGE, ILLINOIS, on this 12th day of MAY, 2014.

PRESIDENT AND VILLAGE BOARD MEMBERS:

	AYES:	NAYS:	ABSENT:	ABSTAIN
Debby Blatzer	_____	_____	_____	_____
Paul Chialdikas	_____	_____	_____	_____
Clifford Miklos	_____	_____	_____	_____
Rick Sniegowski	_____	_____	_____	_____
Ron Stapleton	_____	_____	_____	_____
Jeanette Virgilio	_____	_____	_____	_____

BRIAN K. REAVES, President

ATTEST:

CHARLENE M. SMOLLEN
Village Clerk



Village of Lemont
Planning & Economic Development Department

418 Main Street · Lemont, Illinois 60439
phone 630-257-1595 · fax 630-257-1598

TO: Mayor Reaves
Village Board of Trustees

FROM: Martha M. Glas, Village Planner

THRU: Charity Jones, AICP, Planning & Economic Development Director

SUBJECT: Case 14-02 931 Singer Ave. Variation

DATE: May 8, 2014

SUMMARY

Tracey Nappier, acting on behalf of owner Leslie Zalewski, is seeking a variation from §17.07.020.F.2 of the Unified Development Ordinance. The variation would allow a proposed detached garage to be accessed from the street as opposed to the alley as required by code in the R-4A district. The subject property is a corner lot and is currently vacant. The applicant intends on constructing a home and a detached garage on the property. Access to the garage is proposed off of Peiffer Ave. Staff and PZC recommended approval.

The Committee of the Whole reviewed the application at its April 21, 2014 meeting and concurred with the recommendation of the PZC.

BOARD ACTION

Vote on the attached ordinance.

ATTACHMENTS

An Ordinance Granting A Variation To Allow A Detached Garage Access From A Street (Peiffer Ave.) As Opposed To An Alley As Required In The R-4a District For The Property Located At 931 Singer Ave. In Lemont, Il

**VILLAGE OF LEMONT
ORDINANCE NO. _____**

**AN ORDINANCE GRANTING A VARIATION TO ALLOW A DETACHED GARAGE
ACCESS FROM A STREET (PEIFFER AVE.) AS OPPOSED TO AN ALLEY AS
REQUIRED IN THE R-4A DISTRICT FOR THE PROPERTY LOCATED AT 931
SINGER AVE. IN LEMONT, IL**

(931 Singer Ave.)

**Adopted by the President
and Board of Trustees
of the Village of Lemont
This 12th Day of May, 2014.**

**Published in pamphlet form by
authority of the President and
Board of Trustees of the Village
of Lemont, Cook, DuPage, and Will
Counties, Illinois this 12th day of
May, 2014.**

ORDINANCE NO. _____

AN ORDINANCE GRANTING A VARIATION TO ALLOW A DETACHED GARAGE ACCESS FROM A STREET (PEIFFER AVE.) AS OPPOSED TO AN ALLEY AS REQUIRED IN THE R-4A DISTRICT FOR THE PROPERTY LOCATED AT 931 SINGER AVE. IN LEMONT, IL

(931 Singer Ave.)

WHEREAS, Leslie Zalewski, herein after referred to as “the Petitioner” is the owner of the property at 931 Singer Ave. in Lemont (PIN 22-29-119-010) hereinafter referred to as “the subject property,” legally described and depicted in Exhibit A; and

WHEREAS, the Petitioner is seeking a variation to the Unified Development Ordinance, §17.07.020F(2) to allow a detached garage access from a street (Peiffer Ave.) as opposed to the alley that provides access to the subject property, as required in the R-4A District; and

WHEREAS, the Planning and Zoning Commission of the Village of Lemont, Illinois conducted a Public Hearing on March 19, 2014 and voted 5-0 to recommend approval of the requested variation; and

WHEREAS, a notice of the aforesaid Public Hearing was made in the manner provided by law and was published in the *Lemont Reporter-Met*, a newspaper of general circulation within the Village; and

WHEREAS, the President and Board of Trustees of the Village have reviewed the matter herein and have determined that the same is in the best interest of the public health, safety and welfare of the residents of the Village of Lemont, and hereby adopt the finding of facts as set forth in Exhibit B.

NOW, THEREFORE, BE IT ORDAINED BY THE PRESIDENT AND BOARD OF TRUSTEES OF THE VILLAGE OF LEMONT, COUNTIES OF COOK, DUPAGE, AND WILL, ILLINOIS:

SECTION 1: Incorporation of Recitals. The foregoing findings and recitals are hereby adopted as Section 1 of this Ordinance and are incorporated by reference as if set forth verbatim herein.

SECTION 2: Variation. A variation is granted from the Unified Development Ordinance, §§17.07.020F(2) to allow for access to a detached garage located on the subject property from Peiffer Ave.

SECTION 3: Nothing in this Ordinance shall be construed to be a waiver or a grant of authority to any other section of the Lemont, Illinois Municipal Code, or any other federal, state, or local law, rule or regulation.

SECTION 4: That the Village Clerk of the Village of Lemont be and is directed hereby to publish this Ordinance in pamphlet form, pursuant to the Statutes of the State of Illinois, made and provided.

SECTION 5: That this Ordinance shall be in full force and effect from and after its passage, approval and publication provided by law.

**PASSED AND APPROVED BY THE PRESIDENT AND BOARD OF TRUSTEES
OF THE VILLAGE OF LEMONT, COUNTIES OF COOK, DUPAGE AND WILL,
ILLINOIS, ON THIS 12th DAY OF May, 2014.**

	<u>AYES</u>	<u>NAYS</u>	<u>ABSENT</u>	<u>ABSTAIN</u>
Debby Blatzer				
Paul Chialdikas				
Clifford Miklos				
Ron Stapleton				
Rick Sniegowski				
Jeanette Virgilio				

Approved by me this 12th day of May, 2014

BRIAN K. REAVES, Village President

Attest:

CHARLENE M. SMOLLEN, Village Clerk

EXHIBIT A

PLAT OF SURVEY

LOTS 11 IN BLOCK 3 IN NORTON AND WARNER'S SUBDIVISION OF THE SOUTHEAST QUARTER OF THE NORTHWEST QUARTER OF SECTION 29, TOWNSHIP 37 NORTH, RANGE 11 EAST OF THE THIRD PRINCIPAL MERIDIAN, IN COOK COUNTY, ILLINOIS.

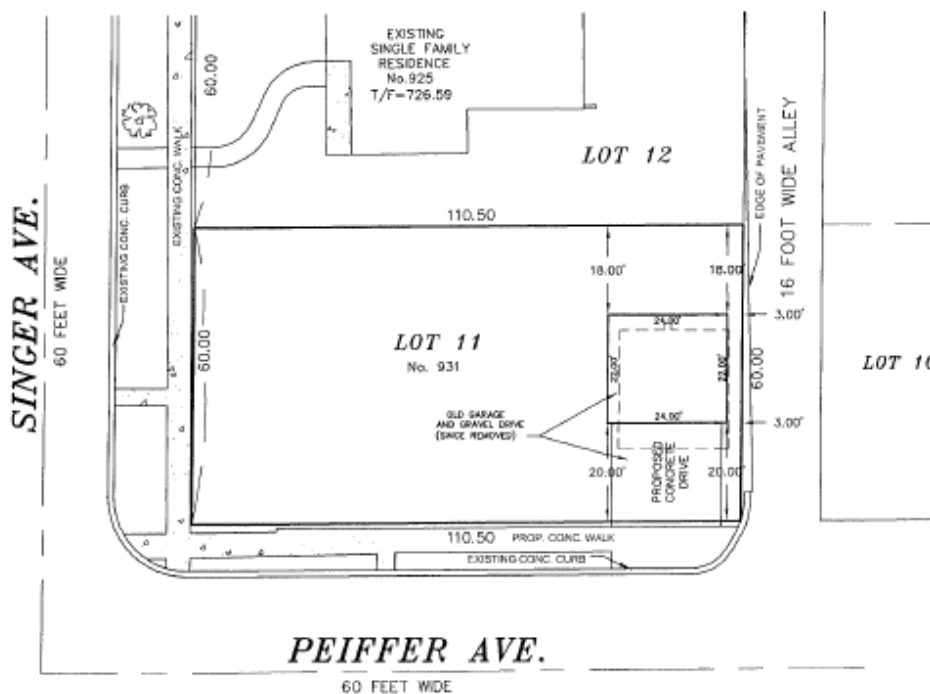

Proposed

NO DATA HEREIN SHOULD BE USED FOR CONSTRUCTION OR ESTABLISHING BOUNDARY OF FENCE LINES. FOR BUILDING RESTRICTIONS AND/OR EASEMENTS, REFER TO THE DEED, CONTRACT, TITLE POLICY OR LOCAL ZONING REGULATIONS.

BOUNDARY DIMENSIONS ARE BASED ON THE PUBLIC RECORDS AND/OR THE LEGAL DESCRIPTION. LEGAL DESCRIPTION ABOVE HAS BEEN PROVIDED BY THE CLIENT AND MUST BE COMPARED WITH DEED AND/OR TITLE POLICY. NO DIMENSIONS SHALL BE ASSUMED BY SCALE MEASUREMENTS ON THIS DOCUMENT.

DISCREPANCIES FOUND BETWEEN FIELD CONDITIONS AND DIMENSIONS SHOWN ON THIS DOCUMENT SHALL BE REPORTED TO THIS OFFICE IMMEDIATELY. LIABILITY OF LANDTECH CONSULTANTS ASSOCIATED WITH THIS DOCUMENT AND THE WORK IT REPRESENTS IS LIMITED TO THE COST OF PRODUCING IT.

LANDTECH CONSULTANTS LTD. AN ILLINOIS PROFESSIONAL DESIGN FIRM, SURVEY AND PROFESSIONAL ENGINEERING CORP. # 184-001289 HEREBY CERTIFIES THAT THE ABOVE DESCRIBED PROPERTY HAS BEEN MEASURED IN THE FIELD AND THAT THIS DOCUMENT IS A TRUE AND CORRECT REPRESENTATION OF SAID FIELD WORK. ALL DIMENSIONS ARE GIVEN IN FEET AND DECIMAL PARTS THEREOF. LANDTECH CONSULTANTS' CORPORATE LICENSE EXPIRES APRIL 30, 2015.

THIS PROFESSIONAL SERVICE CONFORMS TO THE CURRENT ILLINOIS MINIMUM STANDARDS FOR A BOUNDARY SURVEY.

DATED THIS 14TH DAY OF FEB., 2014. CORP. LIC. # 184-001289
 BY ILLINOIS LICENSED PROFESSIONAL LAND SURVEYOR, MATTHEW D. DUNN
 ILLINOIS SURVEYORS LICENSE # 3107, MY LICENSE EXPIRES 11/30/14

JOB NUMBER 140202
 ORDERED BY KEN PASIEWICZ
 COPYRIGHT 2005 LANDTECH CONSULTANTS INC. SCALE: 1" = 20'



ENGINEERING · SURVEYING · LAND PLANNING
 13711 W. 159th STREET LOCKPORT, IL 60441
 PHONE (708)301-6200 FAX (708)301-6204

EXHIBIT B

FINDINGS. Based upon the evidence and testimony presented in the public hearing, the Planning & Zoning Commission finds the following:

1. The variation is consistent with general purpose and intent of the Unified Development Ordinance in that it will not have a negative impact on surrounding properties, or the Village in general. The subject lot is a vacant corner lot and the new home is proposed to face Singer Ave. The driveway will not exit onto Singer Ave. and will therefore not negatively impact the Singer Ave. Block face.
2. A majority of homes along the north side of Peiffer Ave. have driveways that exit onto Peiffer Ave. Therefore, the proposed driveway access will not negatively impact the Peiffer Ave. block face.
3. The property has a utility pole and guy wire on the east lot line adjacent to the alley. The location of the pole and wire limits driveway access from the alley and makes access from this area impractical and creates a hardship for the owner.



Village of Lemont
Planning & Economic Development Department

418 Main Street · Lemont, Illinois 60439
phone 630-257-1595 · fax 630-257-1598

TO: Mayor Reaves
Village Board of Trustees

FROM: Charity Jones, AICP, Planning & Economic Development Director

SUBJECT: Case 14-06 UDO Amendments

DATE: May 8, 2014

SUMMARY

In 2013 staff processed amendments to the UDO, including a proposal to update the Village tree planting specifications. During the drafting of that ordinance, staff decided to review all of the engineering specifications within the UDO, as well as the full list of approved parkway tree species and update all as necessary. Since several items are being updated to reflect current best management practices, the UDO Table F-1 (the approved parkway tree list) and UDO Appendix G (the Engineering Details) are being replaced in their entirety. This approach will minimize the chance of errors occurring with the Village's codifier service.

BOARD ACTION

Vote on the attached ordinance.

ATTACHMENTS

1. An Ordinance Amending Title 17 of the Lemont Municipal Code, the Lemont Unified Development Ordinance of 2008.

**VILLAGE OF LEMONT
ORDINANCE NO. _____**

**AN ORDINANCE AMENDING TITLE 17 OF THE LEMONT MUNICIPAL CODE, THE
LEMONT UNIFIED DEVELOPMENT ORDINANCE OF 2008**

(UDO Amendments)

**ADOPTED BY THE
PRESIDENT AND BOARD OF TRUSTEES
OF THE VILLAGE OF LEMONT
THIS 12th DAY OF MAY, 2014**

**Published in pamphlet form by
authority of the President and
Board of Trustees of the Village
of Lemont, Cook, DuPage, and Will
Counties, Illinois this 12th
day of May, 2014.**

ORDINANCE NO. _____

**AN ORDINANCE AMENDING TITLE 17 OF THE LEMONT MUNICIPAL CODE, THE
LEMONT UNIFIED DEVELOPMENT ORDINANCE OF 2008
(UDO Amendments)**

WHEREAS, the Village of Lemont approved Ordinance O-07-08 adopting the Lemont Unified Development Ordinance of 2008 (hereinafter “the Unified Development Ordinance”) with an effective date of March 15, 2008; and

WHEREAS, the Unified Development Ordinance contains engineering details and other provisions governing the construction and installation of public improvements; and

WHEREAS, such guidelines require periodic updates to remain current with industry best management practices; and

WHEREAS, the Village Board of Trustees hereby finds that the proposed amendments are consistent with the purposes of the Unified Development Ordinance;

NOW, THEREFORE, BE IT ORDAINED by the President and Board of Trustees of the Village of Lemont that:

SECTION 1: Incorporation of Recitals. The foregoing findings and recitals are hereby adopted as Section 1 of this Ordinance and are incorporated by reference as if set forth verbatim herein.

SECTION 2: UDO Text Amendments – Appendix F. Chapter 17 of the Lemont Municipal Code, the Lemont Unified Development Ordinance, Appendix F, is hereby amended by deleting Table F-1 “Trees Approved for Parkway Planting” in its entirety and replacing it with a new Table F-1, attached hereto and incorporated herein as Exhibit A.

SECTION 3: UDO Text Amendments – Appendix G. Chapter 17 of the Lemont Municipal Code, the Lemont Unified Development Ordinance, is hereby amended by deleting Appendix G in its entirety and replacing it with a new Appendix G, attached hereto and incorporated herein as Exhibit B.

SECTION 4: That the Village Clerk of the Village of Lemont be and is directed hereby to publish this Ordinance in pamphlet form, pursuant to the Statutes of the State of Illinois, made and provided.

SECTION 5: Should any Section or provision of this Ordinance be declared by a Court of competent jurisdiction to be invalid, such decision shall not affect the validity of the Ordinance as a whole or any part thereof other than the part declared to be invalid.

SECTION 5: This Ordinance shall be in full force and effect from and after its passage, approval and publication as provided by law.

**PASSED AND APPROVED BY THE PRESIDENT AND BOARD OF TRUSTEES
OF THE VILLAGE OF LEMONT, COUNTIES OF COOK, WILL, AND DUPAGE,
ILLINOIS, on this 12th day of May, 2014.**

PRESIDENT AND VILLAGE BOARD MEMBERS:

	AYES:	NAYS:	ABSENT:	ABSTAIN
Debby Blatzer	_____	_____	_____	_____
Paul Chialdikas	_____	_____	_____	_____
Clifford Miklos	_____	_____	_____	_____
Rick Sniegowski	_____	_____	_____	_____
Ron Stapleton	_____	_____	_____	_____
Jeanette Virgilio	_____	_____	_____	_____

BRIAN K. REAVES
President

ATTEST:

CHARLENE M. SMOLLEN
Village Clerk

Exhibit A

TABLE F-1 Trees Approved for Parkway Planting

SMALL TREES*	
Species	Common Name
<i>Crataegus</i> spp	Hawthorn (thornless)
<i>Maulus</i> 'Prairiefire'	Prairiefire Crabapple
<i>Pyrus calleryana</i> 'Aristocrat'	Aristocrat Pear
LARGE TREES**	
<i>Acer x freemanii</i> 'Autumn Blaze'	Autumn Blaze maple
<i>Acer x freemanii</i> 'Marmo'	Marmo maple
<i>Aesculus glabra</i>	Ohio Buckeye
<i>Catalpa speciosa</i>	Catalpa
<i>Celtis occidentalis</i>	Hackberry
<i>Cercidiphyllum japonicum</i>	Katsuratree
<i>Ginkgo biloba</i> (male)	Ginkgo
<i>Gleditsia triacanthos</i> var. <i>inermis</i> 'Shademaster'	Shademaster Honeylocust
<i>Gleditsia triacanthos</i> var. <i>inermis</i> 'Skyline'	Skyline Honeylocust
<i>Platanus X acerifolia</i> 'Morton Circle'	Exclamation! London Planetree
<i>Gymnocladus dioicus</i>	Kentucky Coffeetree
<i>Quercus alba</i>	White Oak
<i>Quercus bicolor</i>	Swamp White Oak
<i>Quercus ellipsoidalis</i>	Hill's Oak
<i>Quercus macrocarpa</i>	Bur Oak
<i>Quercus muehlenbergii</i>	Chinquapin Oak
<i>Quercus rubra</i>	Red Oak
<i>Taxodium disticum</i>	Baldcypress
<i>Tilia Americana</i>	American Linden (Basswood)
<i>Tilia americana</i> 'Redmond'	Redmond Linden
<i>Tilia cordata</i> 'Glenleven'	Glenleven Littleleaf Linden
<i>Tilia cordata</i> 'Greenspire'	Greenspire Littleleaf Linden
<i>Ulmus</i> 'Morton' <i>accolade</i>	Morton Elm
<i>Ulmus</i> 'Morton Glossy'	Morton Triumph Elm
<i>Ulmus carpinifolia</i>	Homestead Elm

* Small trees only permitted for use where overhead restrictions exist, e.g. utility lines

** No more than 10% of trees planted within a development can be of the same species

Exhibit B

APPENDIX G

ENGINEERING DETAILS

This appendix contains the following detail sheets, which are hereby made part of this Unified Development Ordinance:

Typical Pavement Section	LS – 1a
Minimum Pavement Cross-Sections	LS – 1b
Curb and Gutter	LS – 2
Driveway Approach	LS – 3
Curb Ramps	LS – 4
Driveway Aprons and Alley Returns	LS – 5
Residential Driveway	LS – 6
Parking Lot	LS – 7
Silt Fence	LS – 8
Residential Right-of-Way	LS – 10
Bedding and Backfill	LS – 20
Thrust Blocks	LS – 21
Water Valve Vault	LS – 22
Valve Box	LS – 23
Water Service Connection	LS – 24
Hydrant and Valve	LS – 25
Sanitary Sewer Service Connection	LS – 40
Sanitary Service Riser	LS – 41
Sanitary Manhole	LS – 42
Drop Pipe Assembly	LS – 43
Inlet, Type A	LS – 60
Catch Basin, Type A	LS – 61
Storm Manhole	LS – 62
Storm Water Manhole (sewers larger than 42”)	LS – 63
Flat Slab Manhole Top	LS – 64
Storm Water Restrictor	LS – 65
Typical Residential Grouping	LS – 66
Typical Detention Pond	LS – 67
Catch Basin, Type C	LS – 68
Grating for Concrete Flared End Section	LS – 69
Utility Street Cuts	LS – 70
Catch Basin Frame & Storm Grates	LS – 71
Street Lighting	LS – 80
Connection Pedestals	LS – 81
Tree Planting	LS – 90
Mail Box	LS – 91
Down Spout Gravity Sewer Connection	LS – 92
Sidewalk Vaults	LS – 93

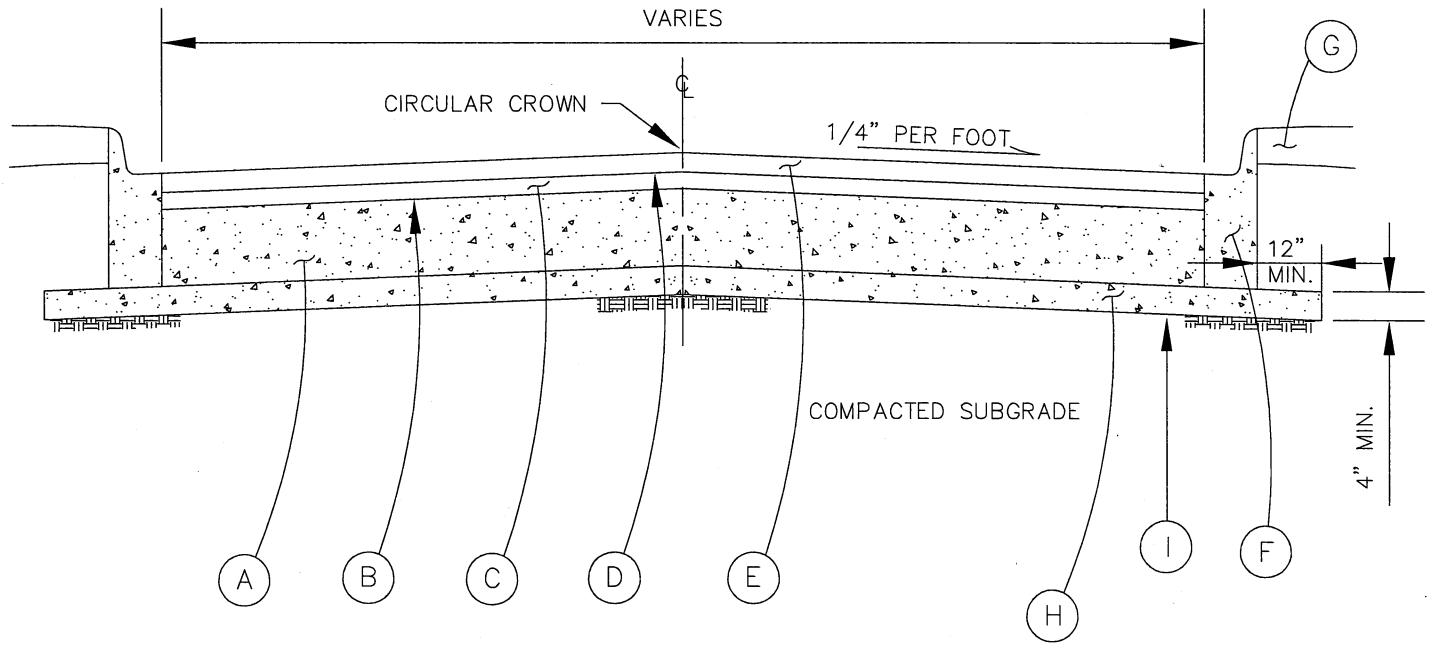

FLEXIBLE PAVEMENT SECTION

SCHEDULE

- A HOT MIX ASPHALT BASE COURSE, N50
- B BITUMINOUS MATERIALS PRIME COAT (0.10 GAL./S.Y.)
- C HOT MIX ASPHALT BINDER COURSE, N50
- D TACK COAT (0.15 GAL./ S.Y.)
- E HOT MIX ASPHALT SURFACE COURSE, MIX C, N50
- F PORTLAND CEMENT CONCRETE CURB AND GUTTER (SEE DETAIL LS-2)
- G TOPSOIL (4" MINIMUM)
- H SUBGRADE GRANULAR MATERIAL, TYPE B, 4"
- I GEOTECHNICAL FABRIC FOR SOIL STABILIZATION

SEE STANDARDS LS-1B FOR PAVEMENT THICKNESS

VILLAGE OF LEMONT

TYPICAL PAVEMENT SECTION

REV. 6/23/08

12/10/01

NO. LS-1a

REV. 3

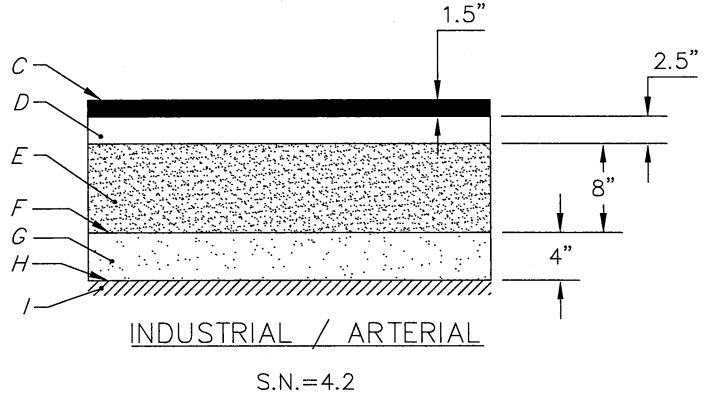
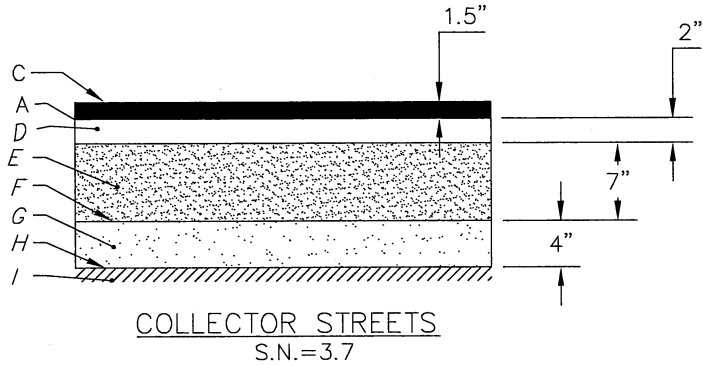
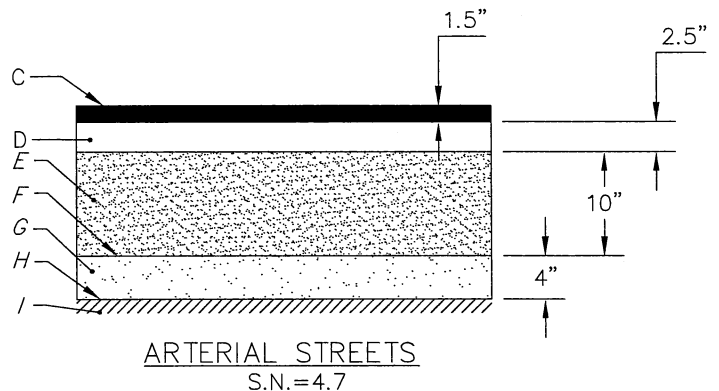
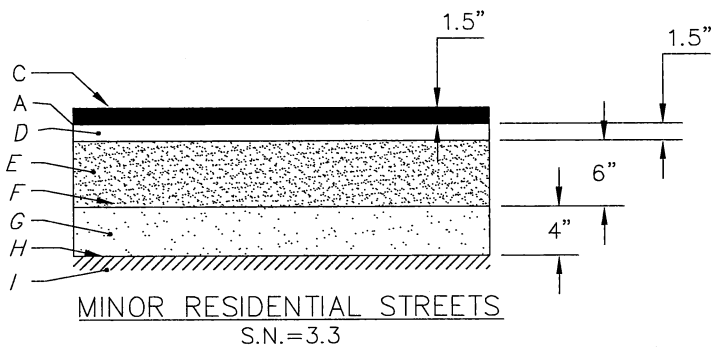

SCHEDULE

- A. 0.10 GAL./S.Y. Bituminous Materials (Prime Coat)
- B. P.C.C., Min. 6-Bag Mix
- C. Hot Mix Asphalt Surface Course, Mix C, N50
- D. Hot Mix Asphalt Binder Course, N50
- E. Hot Mix Asphalt Base Course N50
- F. 0.15 Gal./SY Bit. Materials (Prime Coat)
- G. Aggr. Base Course, Type B, CA-6
- H. Geotechnic Fabric for Soil Stabilization. See Note 4
- I. Approved Subgrade

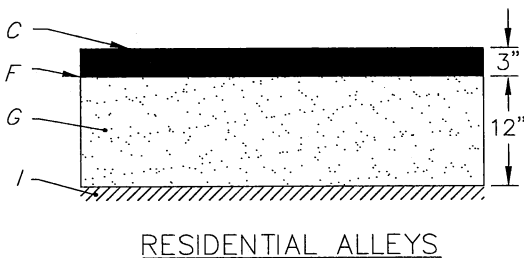
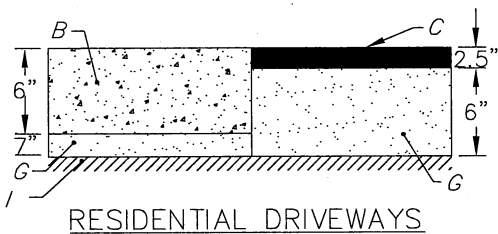
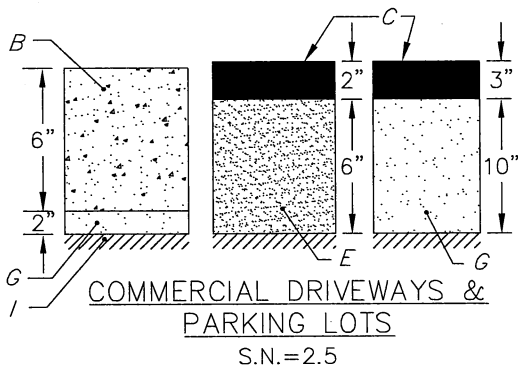

NOTES

1. These Are Minimum Standards Only. Structural Design of Streets Shall be Determined Using State Highway Standards, (With These Minimums) Except Where Approved by Village Engineer.
2. 2% Circular Crown to be Installed on All Streets
3. 2% Inverted Crown to be Installed in Alleys.
4. Geotechnic Fabric Over Subgrade shall be Minimum 4 oz. per Square Yard. Woven or Non-Woven Engineering Fabric, Meeting State Standards.

VILLAGE OF LEMONT		
MINIMUM PAVEMENT CROSS SECTIONS		
12/10/01	NO. LS-1b	REV. 2

REV. 6/23/08

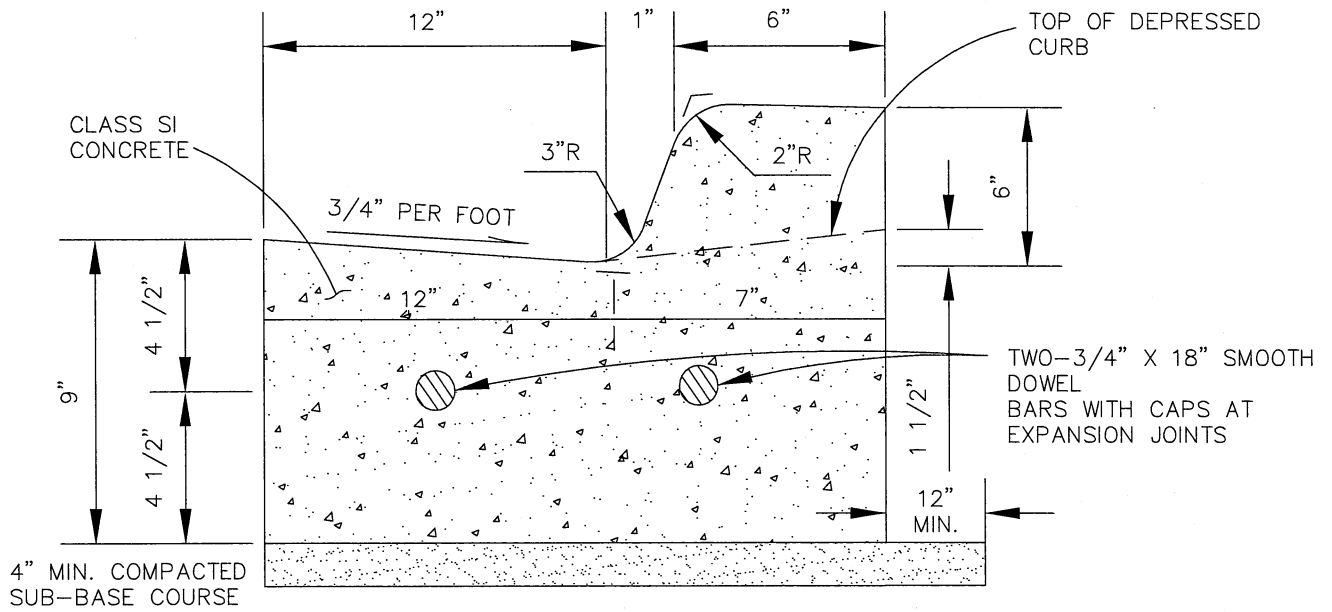

STANDARD BARRIER AND DEPRESSED CURB AND GUTTER

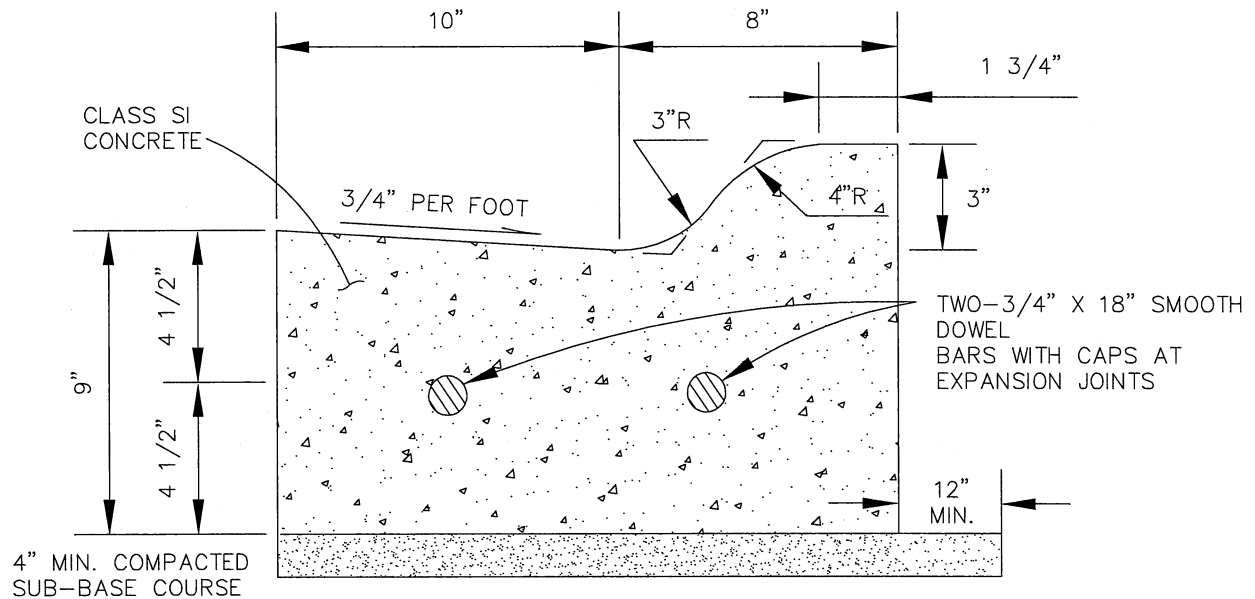

TYPICAL ROLLED CURB AND GUTTER

NOTES:

1. CONSTRUCT CONTRACTION JOINTS AT 20' MAXIMUM SPACING
2. CONSTRUCT EXPANSION JOINTS AND CONTRACTION JOINTS ACCORDING TO IDOT STANDARD SPECIFICATIONS, LATEST EDITION
3. EXPANSION JOINTS SHALL BE PROVIDED AT POINTS OF CURVATURE ON ALL CURVES
4. CURING AND SEALING COMPOUND SHALL BE W.R. MEADOWS INC. "LIN-SEAL" EMULSION, OR APPROVED EQUAL

VILLAGE OF LEMONT

CURB AND GUTTER

REV. 6/23/08

12/10/01

NO. LS-2

REV. 3

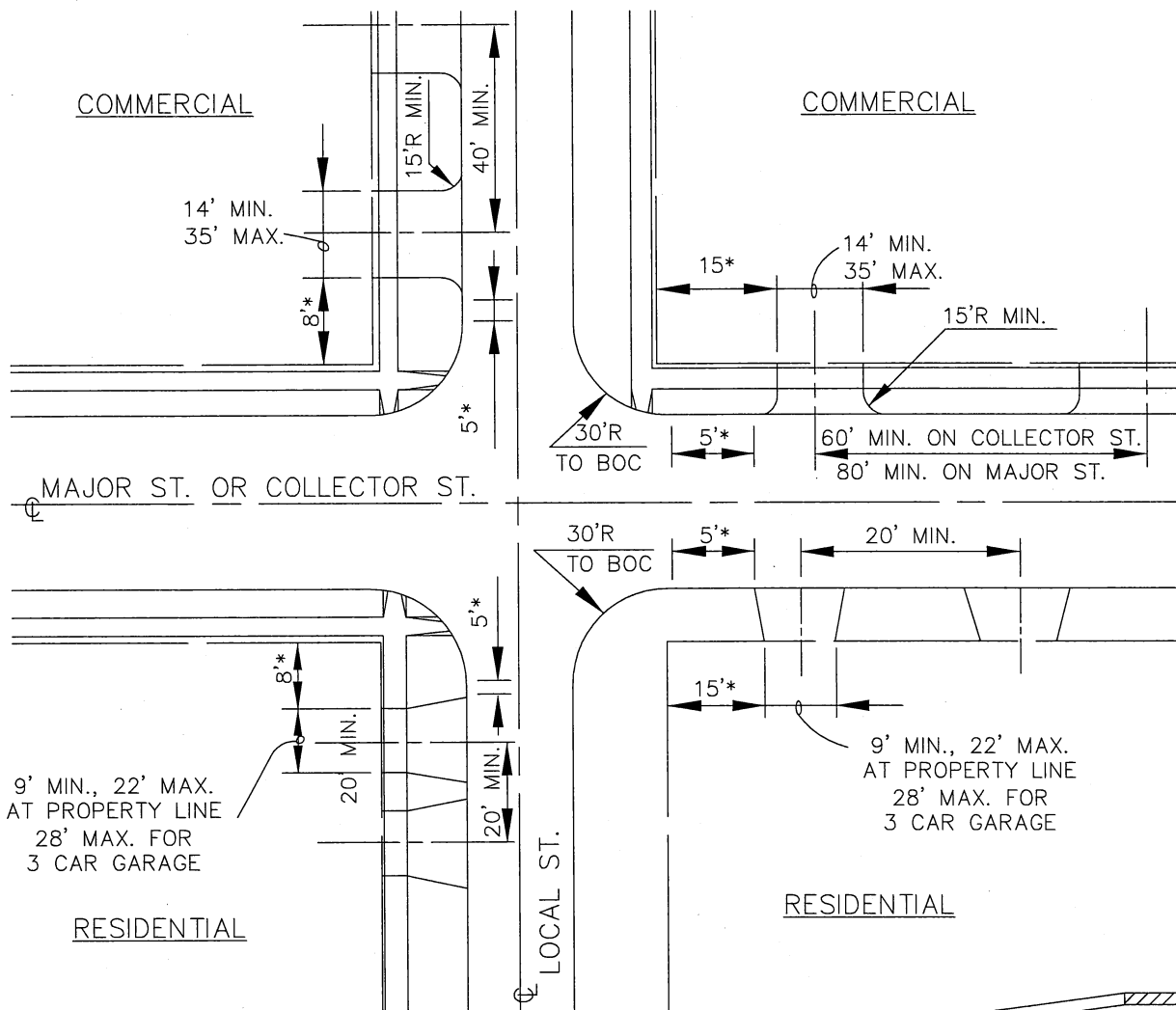

NOTES:

1. EXPANSION MATERIAL IS REQUIRED BETWEEN CONCRETE DRIVES AND CURB OR SIDEWALK
2. WHERE NEW CONCRETE WORK MEETS OR ABUTS EXISTING CONCRETE, THE EXISTING CONCRETE SHALL BE SAWCUT TO A STRAIGHT AND CLEAN EDGE AND EXPANSION MATERIAL PLACED BETWEEN THE NEW AND EXISTING WORK.
3. ALL CURB REPLACEMENTS MUST BE AT LEAST 3 FEET IN LENGTH.
4. DRIVEWAY COMPOSITION SHALL BE PER LEMONT STANDARDS NO. LS-16.
5. CONTRACTION JOINTS SHALL BE IN ACCORDANCE WITH SECTION 3.04 OF THE LEMONT STANDARD SPECIFICATIONS WHERE DRIVEWAYS ARE LARGER THAN 12 FEET IN ANY DIRECTION, JOINTS SHALL BE EVENLY SPACED.

*WHICH EVER IS GREATER

DEPRESSED CURB SIDEWALK AND GUTTER

MAXIMUM DRIVEWAY/PARKWAY SLOPE 8%

TYPICAL SECTION

VILLAGE OF LEMONT

DRIVEWAY APPROACH

REV. 6/23/08

12/10/01

NO. LS-3

REV. 2

REV. 2/27/13

12/10/01

NO. LS-4d

REV. 4

CURB RAMPS

VILLAGE OF LEMONT

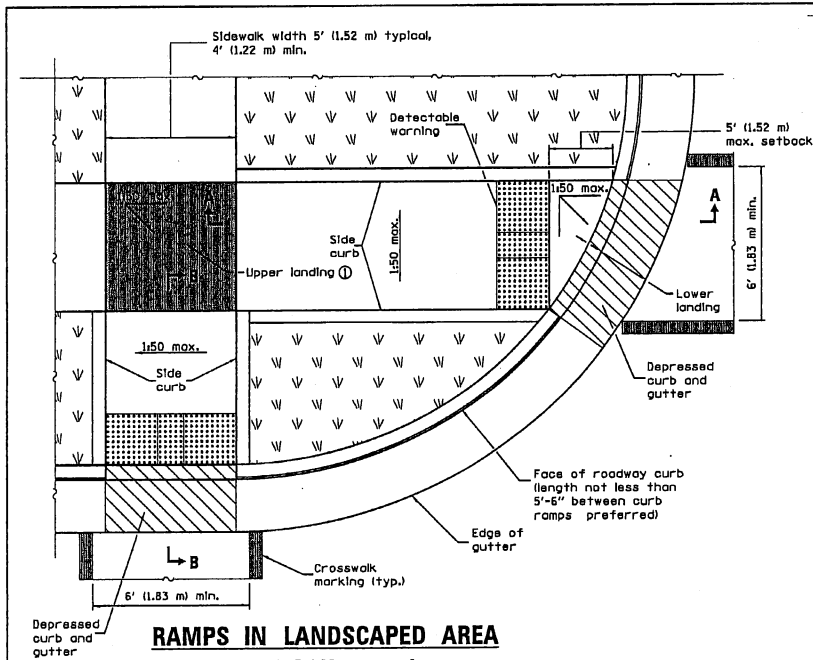

RAMPS IN LANDSCAPED AREA
SETBACK ≤ 5'

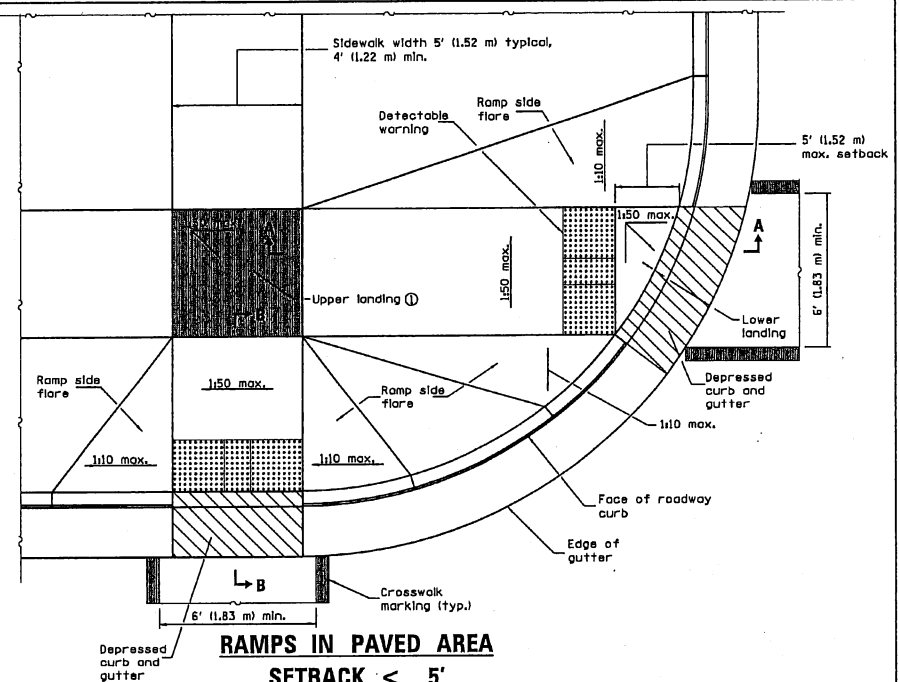

RAMPS IN PAVED AREA
SETBACK ≤ 5'

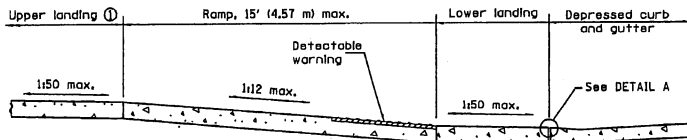

SECTION A-A

① Upper landing not required for ramp slopes flatter than 1:20.

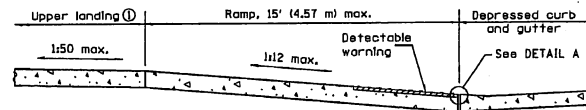

SECTION B-B

① Upper landing not required for ramp slopes flatter than 1:20.

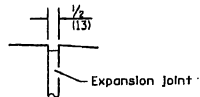

DETAIL A

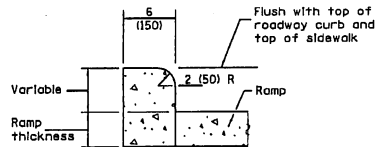

SIDE CURB DETAIL

GENERAL NOTES

All slope ratios are expressed as units of vertical displacement to units of horizontal displacement (V:H).

Where 1:50 maximum slope is shown, 1:64 is preferred.

See Standard 506001 for details of depressed curb adjacent to curb ramp.

All dimensions are in inches (millimeters) unless otherwise shown.

Illinois Department of Transportation
PASSED January 1, 2013
Michael Board
ENGINEER OF POLICY AND PROCEDURES
APPROVED January 1, 2013
ENGINEER OF DESIGN AND ENVIRONMENT

ISSUED 1-1-97

DATE	REVISIONS
1-1-13	Widened crosswalk markings to 6' (1.83 m) min. inside dimension. Rev. Gen. Notes.
1-1-12	Completely revised and renamed standard.

PERPENDICULAR CURB RAMPS FOR SIDEWALKS

(Sheet 1 of 2)

STANDARD 424001-07

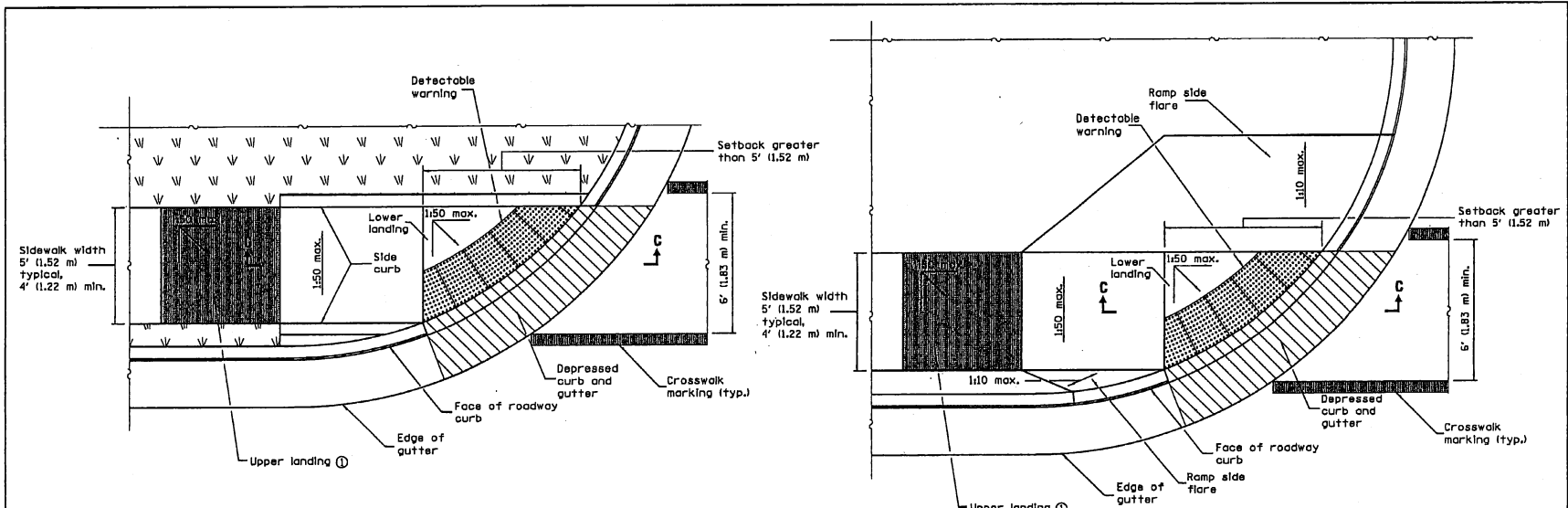

**RAMP IN LANDSCAPED AREA
SETBACK > 5'**

**RAMP IN PAVED AREA
SETBACK > 5'**

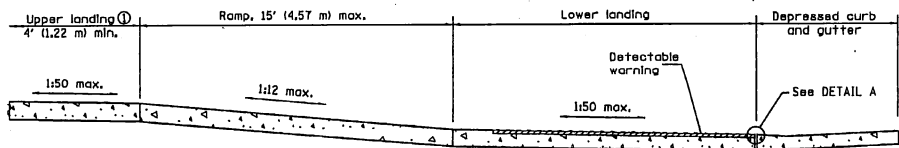

SECTION C-C

① Upper landing not required for ramp slopes flatter than 1:20.

Illinois Department of Transportation
 PASSED January 1, 2013
 Michael B. [Signature]
 ENGINEER OF POLICY AND PROCEDURES
 APPROVED January 1, 2013
 [Signature]
 ENGINEER OF DESIGN AND ENVIRONMENT

**PERPENDICULAR CURB RAMPS
FOR SIDEWALKS**
 (Sheet 2 of 2)
 STANDARD 424001-07

REV. 2/27/13

12/10/01

NO. LS-4b

REV. 4

CURB RAMPS

VILLAGE OF LEMONT

REV. 2/27/13

12/10/01 NO. LS-4c

REV. 4

CURB RAMPS

VILLAGE OF LEMONT

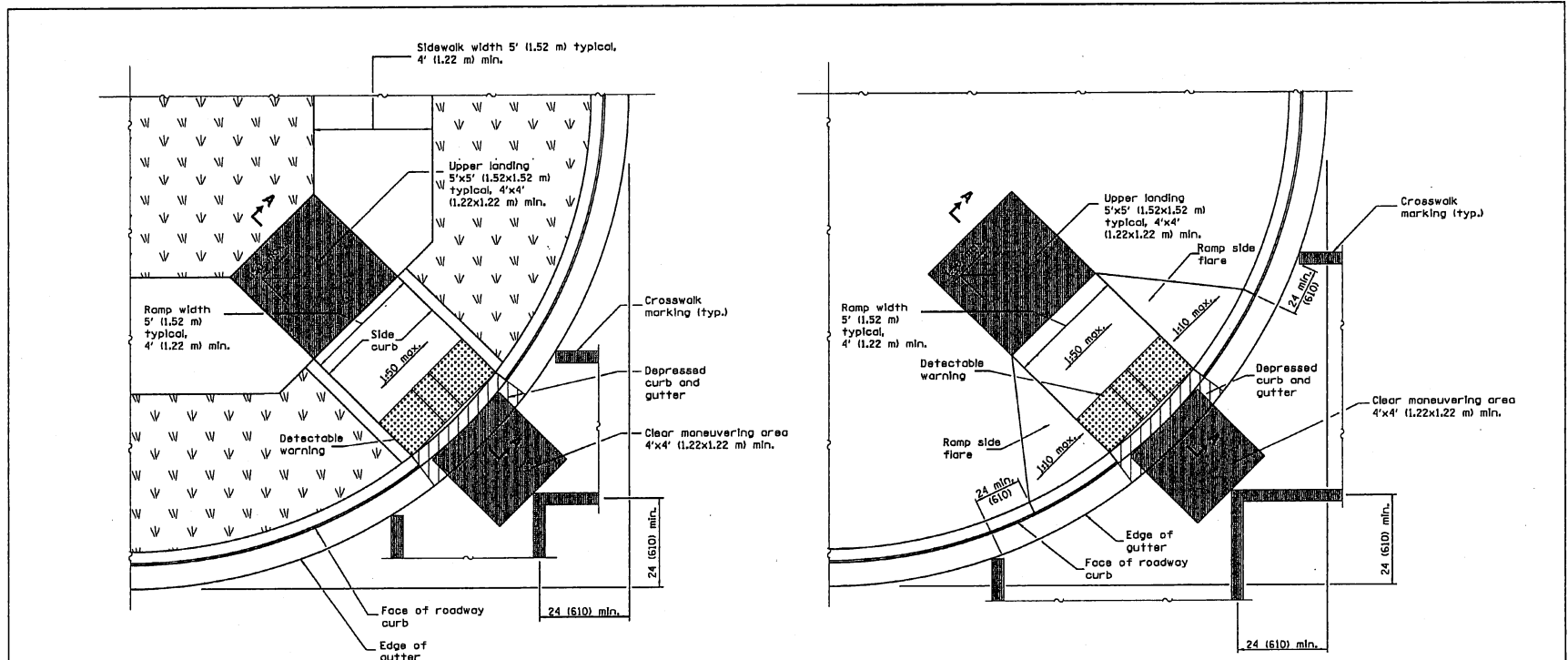

RAMP IN LANDSCAPED AREA

RAMP IN PAVED AREA

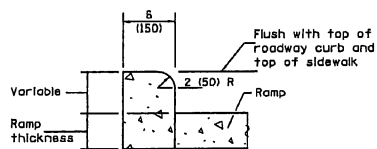

SIDE CURB DETAIL

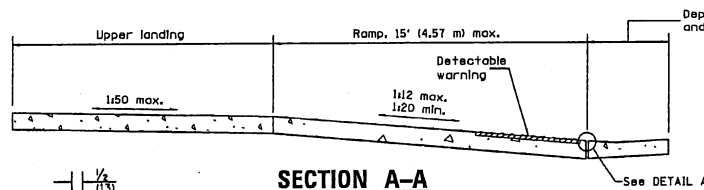

SECTION A-A

DETAIL A

GENERAL NOTES

This Standard shall only be used for curb radii of 20 ft. (6.1 m) or greater.

Where 1:50 maximum slope is shown, 1:64 is preferred.

All slope ratios are expressed as units of vertical displacement to units of horizontal displacement (V:H).

See Standard 606001 for details of depressed curb adjacent to curb ramp.

All dimensions are in inches (millimeters) unless otherwise shown.

Illinois Department of Transportation
 PASSED January 1, 2013
 Michael Beard
 ENGINEER OF POLICY AND PROCEDURES
 APPROVED January 1, 2013
 ENGINEER OF DESIGN AND ENVIRONMENT

ISSUED 1-1-12

DATE	REVISIONS
1-1-13	Revised General Notes.
1-1-12	New standard.

**DIAGONAL CURB RAMPS
 FOR SIDEWALKS**

STANDARD 424006-01

REV. 2/27/13

12/10/01 NO. LS-4d

REV. 4

CURB RAMPS

VILLAGE OF LEMONT

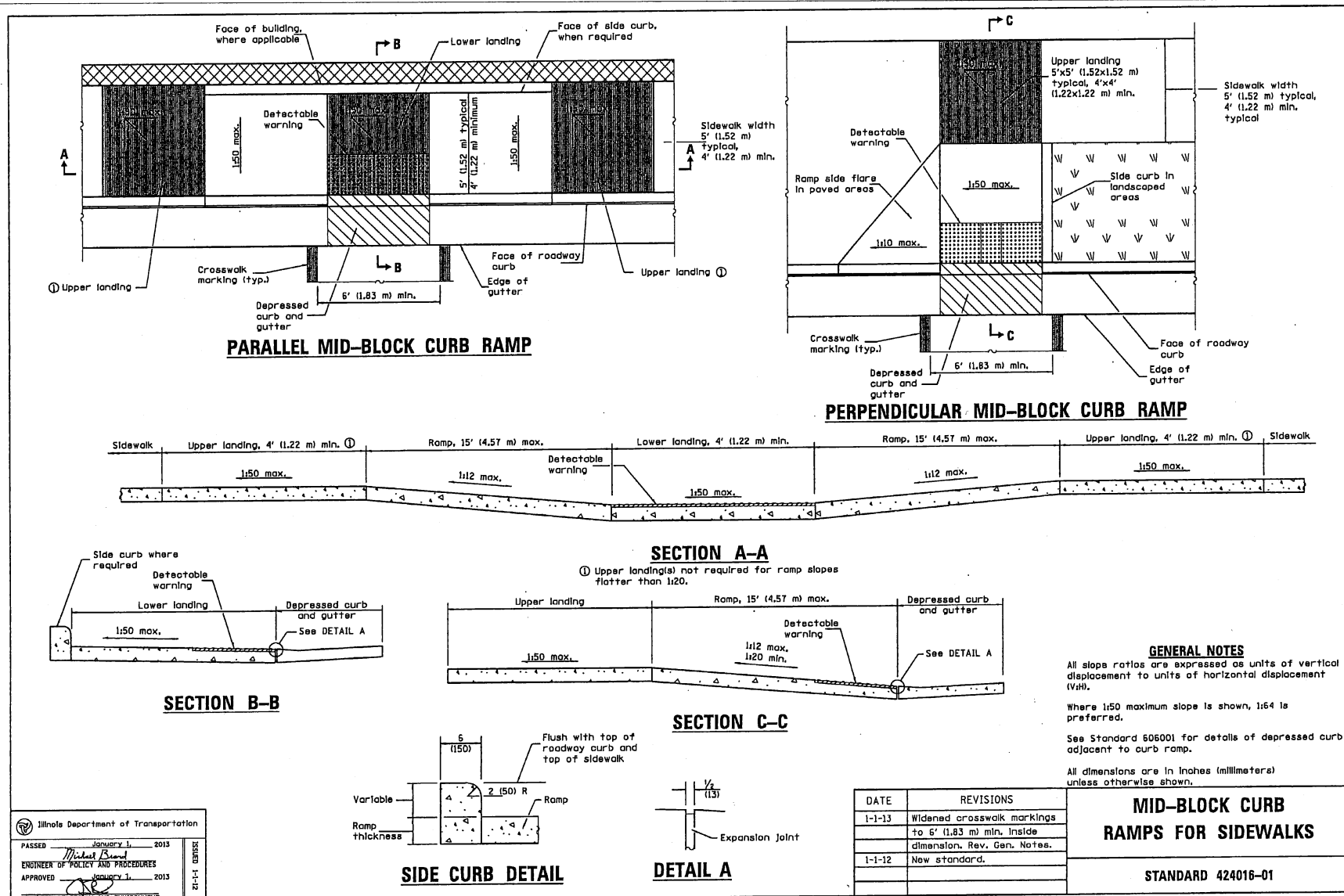

Illinois Department of Transportation
 PASSED January 1, 2013
 Michael Beard
 ENGINEER OF POLICY AND PROCEDURES
 APPROVED January 1, 2013
 ENGINEER OF DESIGN AND ENVIRONMENT

SEAL NO. 1-1-12

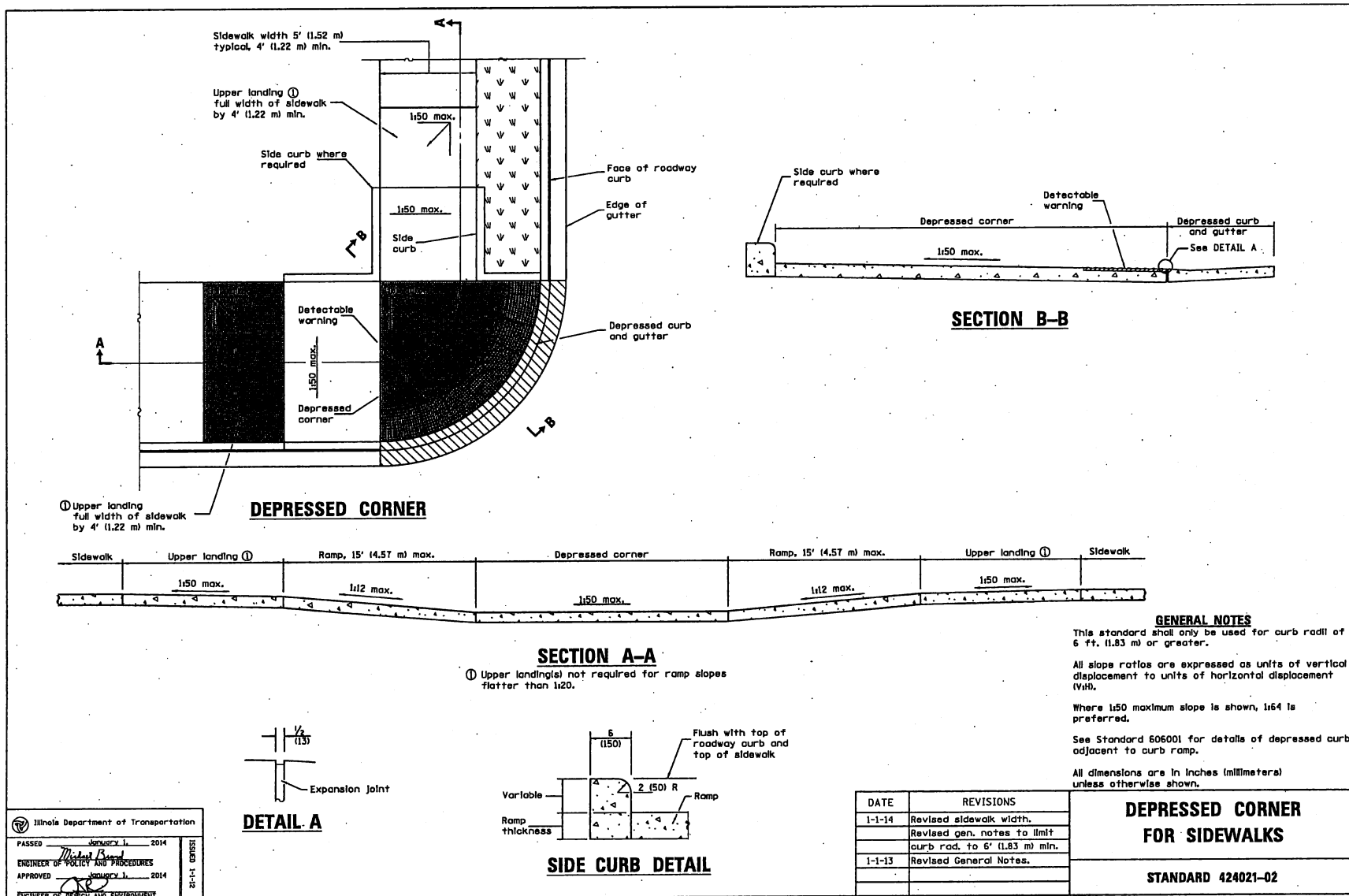

Illinois Department of Transportation

PASSED SENIORITY 1, 2014

ENGINEER OF POLICY AND PROCEDURES

APPROVED SENIORITY 1, 2014

ENGINEER OF DESIGN AND ENVIRONMENT

ISSUED 1-1-13

REV. 2/27/13
REV. 12/20/13

VILLAGE OF LEMONT

CURB RAMPS

12/10/01 NO. LS-4e

REV. 5

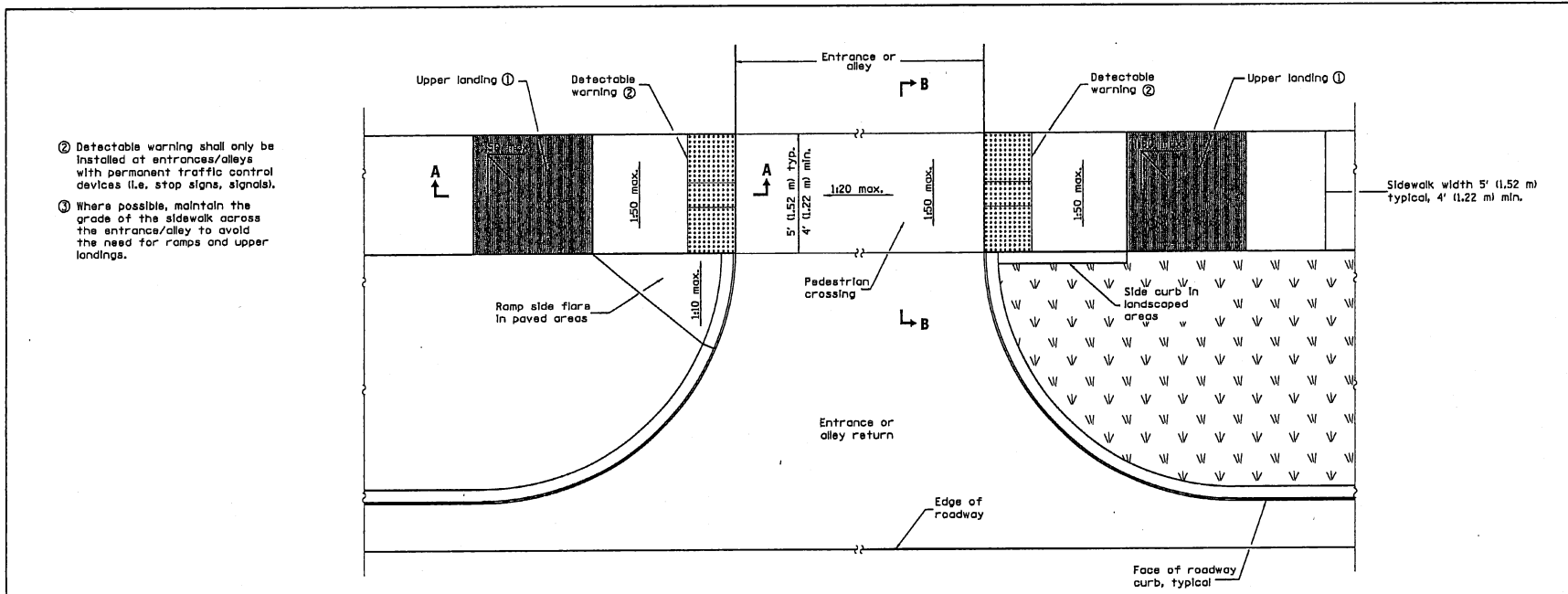

- ② Detectable warning shall only be installed at entrances/alleys with permanent traffic control devices (i.e. stop signs, signals).
- ① Where possible, maintain the grade of the sidewalk across the entrance/alley to avoid the need for ramps and upper landings.

ENTRANCE /ALLEY PEDESTRIAN CROSSING

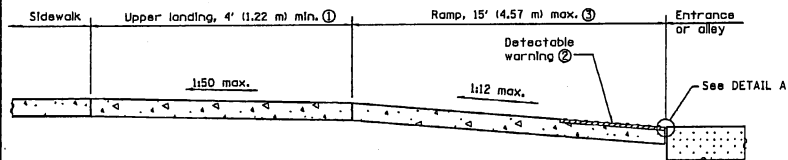

SECTION A-A

① Upper landing not required for ramp slopes flatter than 1:20.

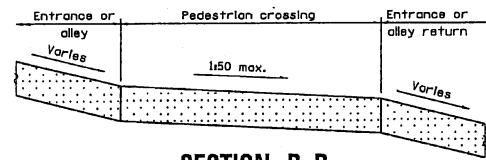

SECTION B-B

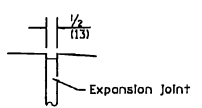

DETAIL A

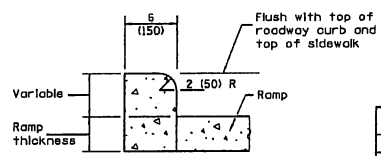

SIDE CURB DETAIL

GENERAL NOTES

All slope ratios are expressed as units of vertical displacement to units of horizontal displacement (V/H).
 Where 1:50 maximum slope is shown, 1:64 is preferred.
 All dimensions are in inches (millimeters) unless otherwise shown.

DATE	REVISIONS
1-1-13	Revised General Notes.
1-1-12	New standard.

ENTRANCE /ALLEY PEDESTRIAN CROSSINGS

STANDARD 424026-01

REV. 2/27/13

12/10/01

NO. LS-4f

REV. 4

VILLAGE OF LEMONT
 CURB RAMPS

Illinois Department of Transportation
 PASSED January 1, 2013
 Michael Beard
 ENGINEER OF POLICY AND PROCEDURES
 APPROVED January 1, 2013
 ENGINEER OF DESIGN AND ENVIRONMENT

REV. 2/27/13

12/10/01 NO. LS-4g

REV. 4

CURB RAMPS

VILLAGE OF LEMONT

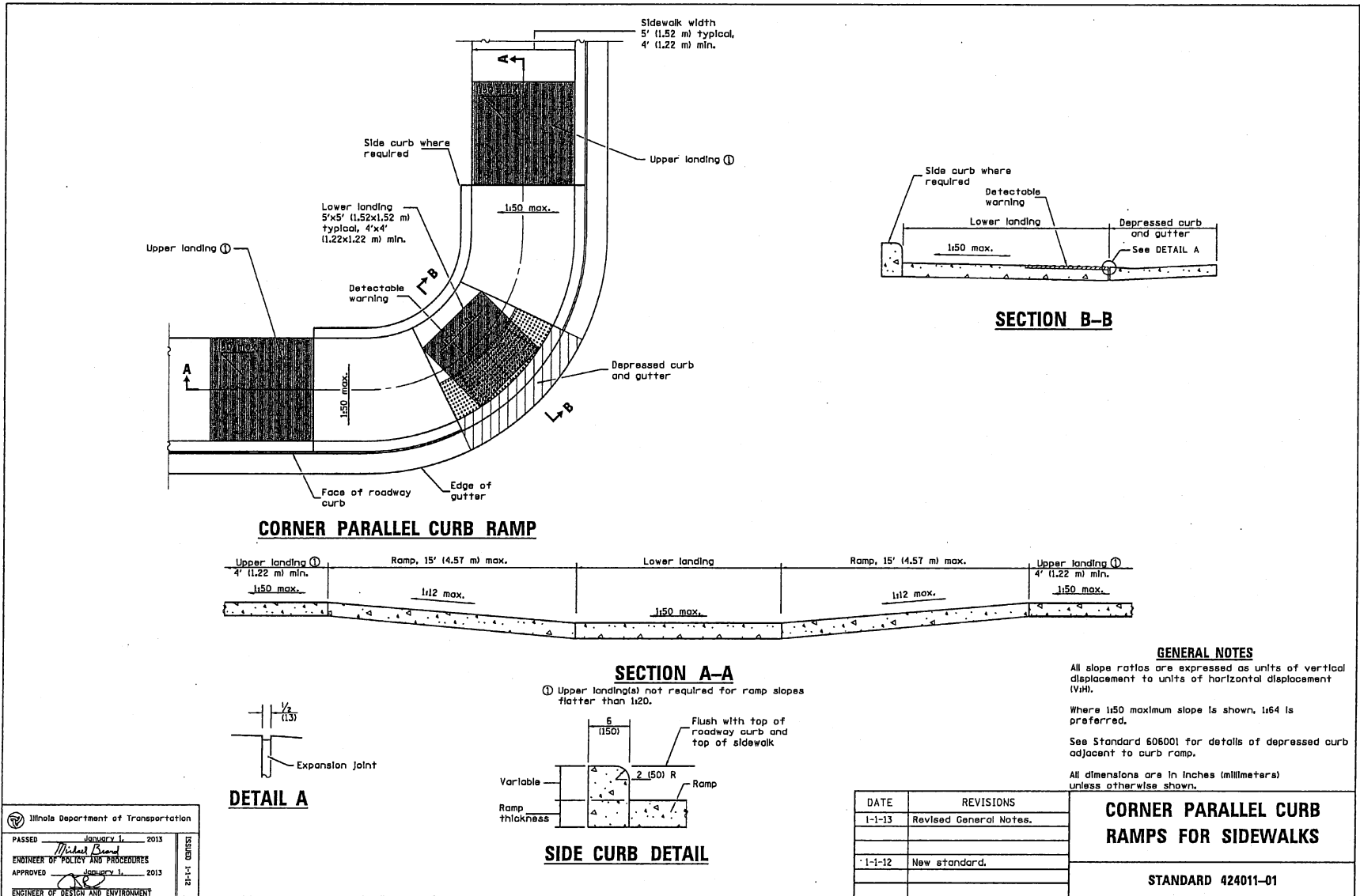

Illinois Department of Transportation	
PASSED	January 1, 2013
ENGINEER OF POLICY AND PROCEDURES	
APPROVED	
ENGINEER OF DESIGN AND ENVIRONMENT	

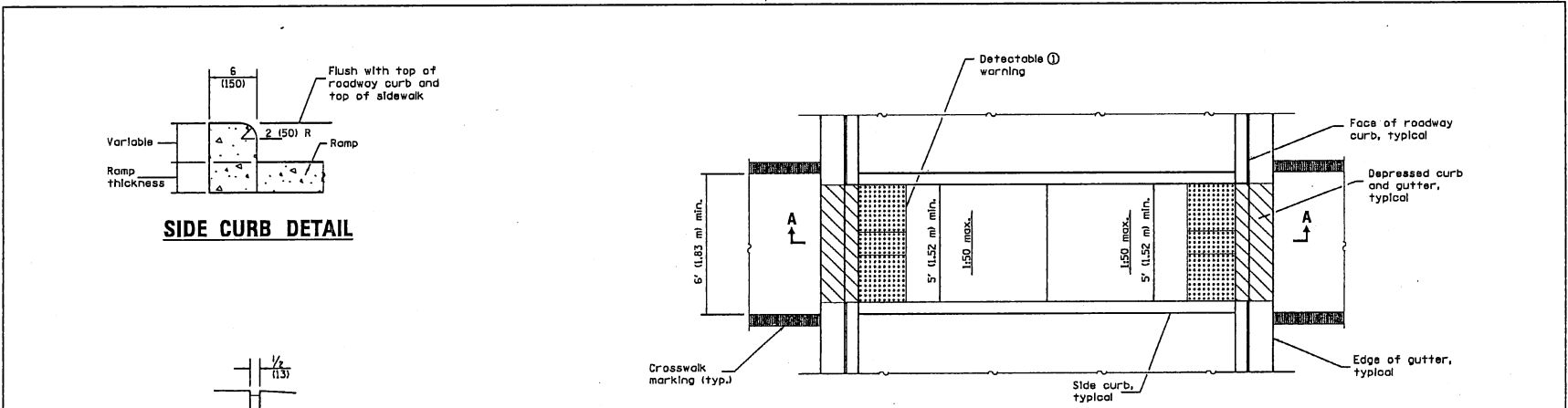

SIDE CURB DETAIL

MEDIAN PEDESTRIAN CROSSING

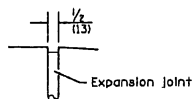

DETAIL A

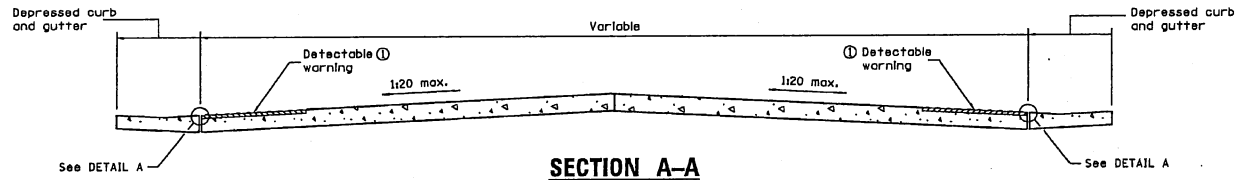

SECTION A-A

⓪ Omit detectable warnings when distance between back of curbs is less than 6' (1.83 m).

GENERAL NOTES

All slope ratios are expressed as units of vertical displacement to units of horizontal displacement (V:H).
 Where 1:50 maximum slope is shown, 1:64 is preferred.
 See Standard 606001 for details of depressed curb adjacent to curb ramp.
 All dimensions are in inches (millimeters) unless otherwise shown.

Illinois Department of Transportation

PASSED January 1, 2013
Michael Beard
 ENGINEER OF POLICY AND PROCEDURES

APPROVED January 1, 2013
[Signature]
 ENGINEER OF DESIGN AND ENVIRONMENT

ISSUED 1-1-12

DATE	REVISIONS
1-1-12	Widened crosswalk to 6'
	(1.83 m) min. inside dimension.
	Revised General Notes.
1-1-12	New standard.

MEDIAN PEDESTRIAN CROSSINGS
STANDARD 424031-01

REV. 2/27/13

VILLAGE OF LEMONT
 CURB RAMPS
 12/10/01 NO. LS-4h REV. 4

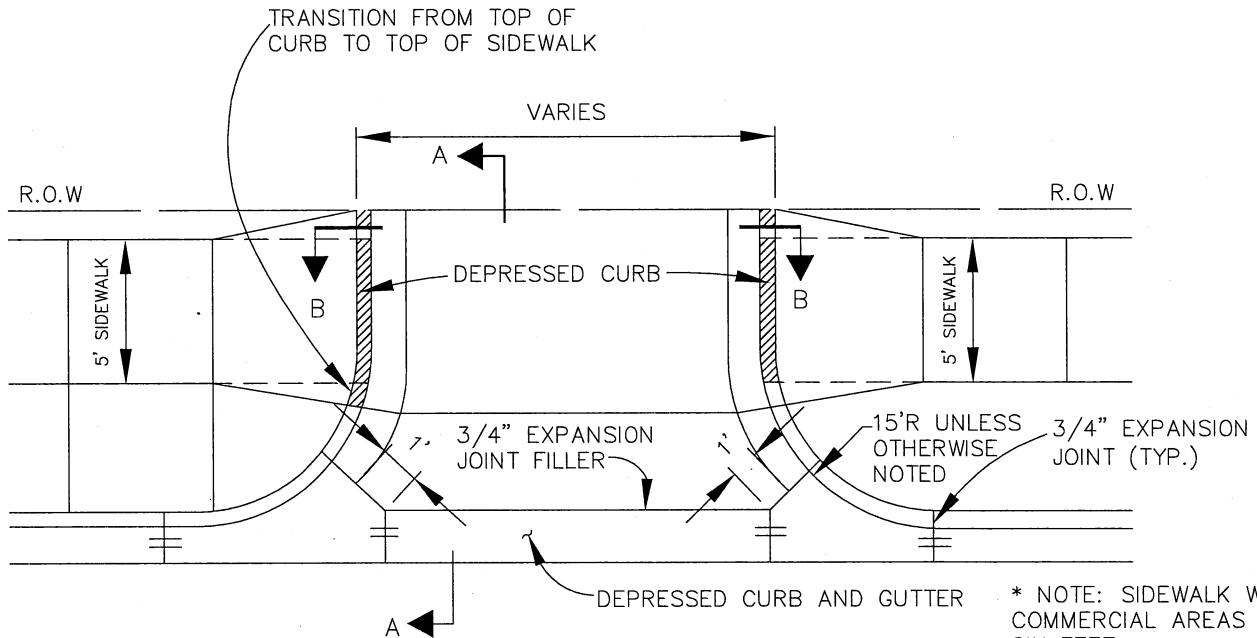

TYPICAL DRIVEWAY APRON AND ALLEY RETURN

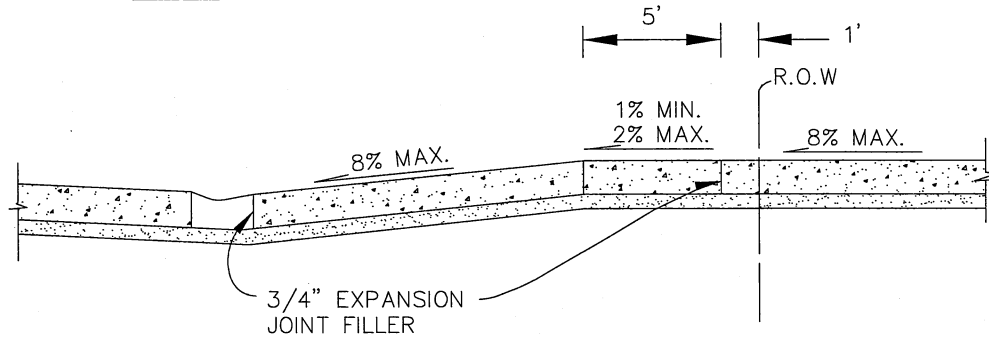

SECTION A-A

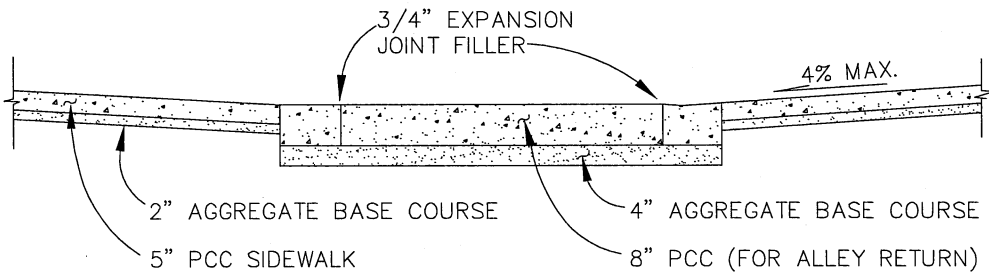

SECTION B-B

* SEE STANDARD LS 6 RESIDENTIAL FOR DRIVEWAY PAVEMENT COMPOSITION

VILLAGE OF LEMONT		
DRIVEWAY APRONS AND ALLEY RETURNS		
REV. 6/23/08	12/10/01	NO. LS-5
		REV. 2

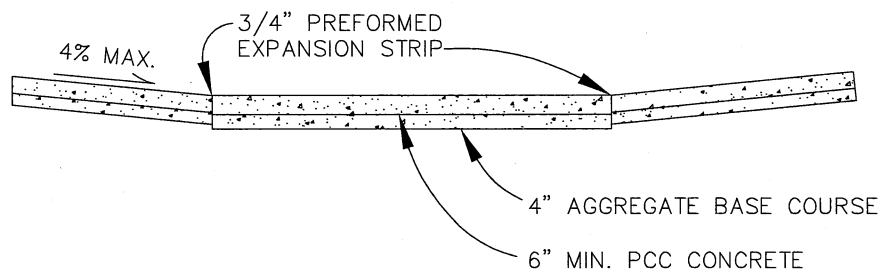
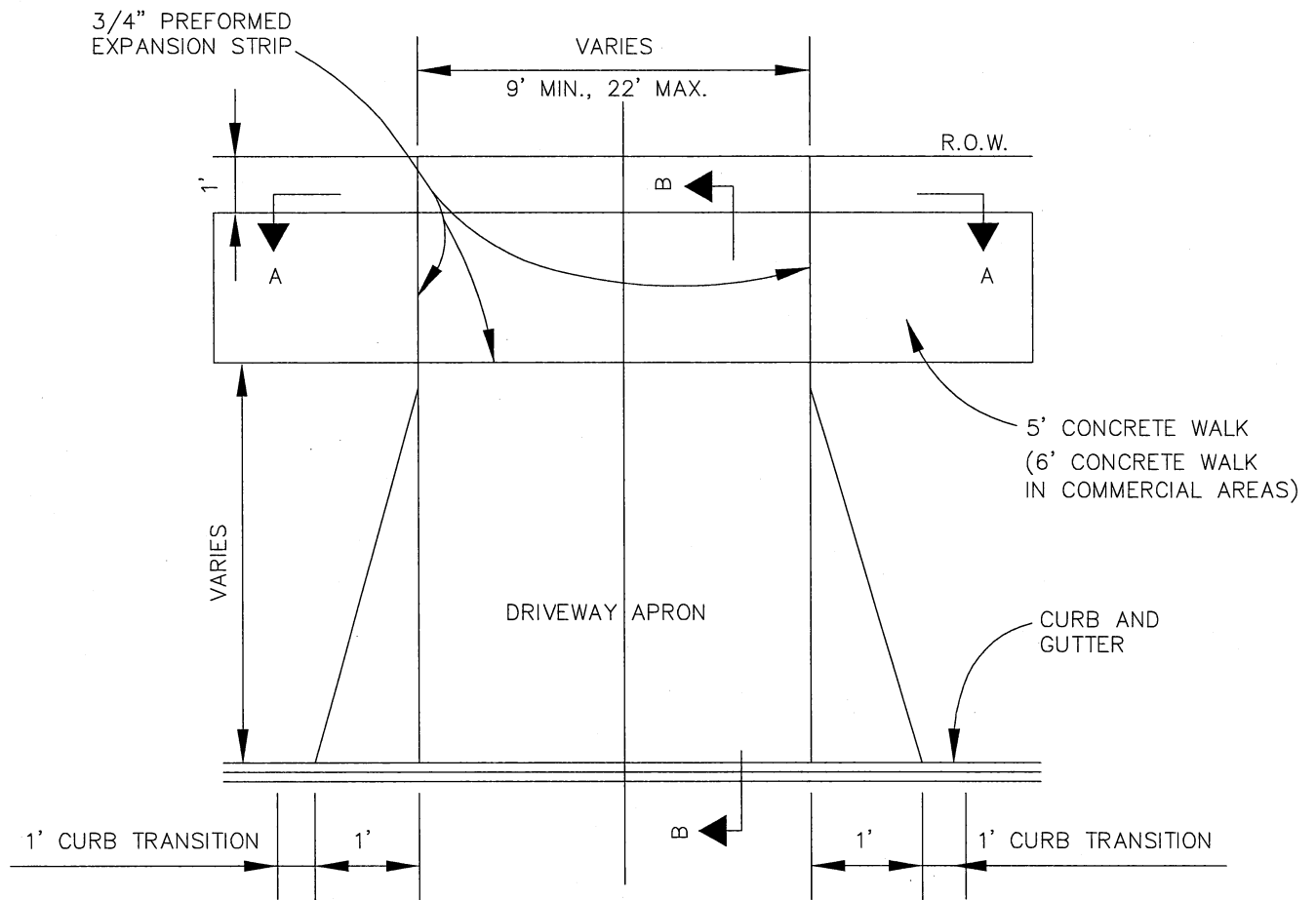

SECTION A-A

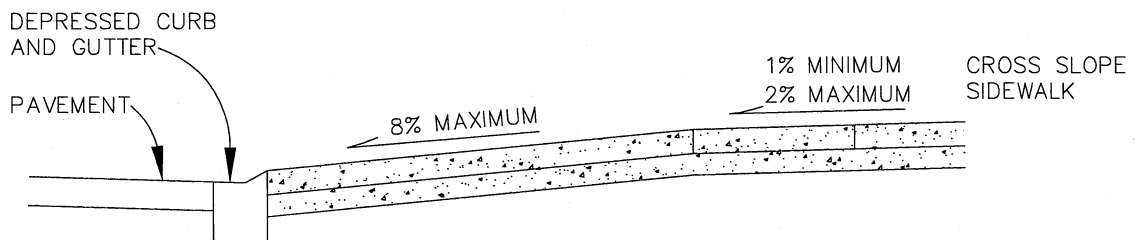

SECTION B-B

NOTES:

DRIVEWAY PAVEMENT ALTERNATES:

- (A) 6" PC CONCRETE
4" COMPACTED AGGREGATE BASE COURSE (CA6)
- (B) 2.5" BITUMINOUS CONCRETE SURFACE, CLASS I
6" COMPACTED AGGREGATE BASE COURSE (CA6)

VILLAGE OF LEMONT

RESIDENTIAL DRIVEWAY

REV. 6/23/08

12/10/01

NO. LS-6

REV. 2

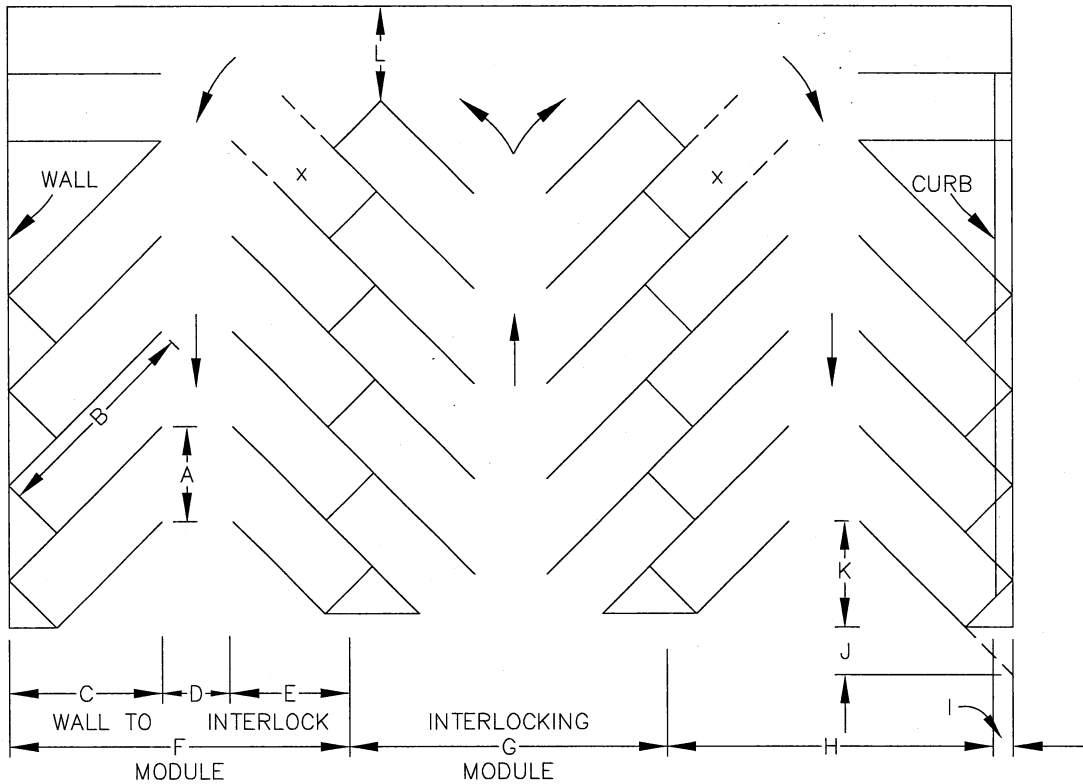

DIMENSIONS (FT.)	ON DIAGRAM	STANDARD U.S. VEHICLE STALL ANGLE*			
		45	60	75	90
STALL WIDTH, PARALLEL TO AISLE	A	12.7	10.4	9.3	9.0
STALL LENGTH OF LINE	B	25.0	22.0	20.0	18.0
STALL DEPTH TO WALL	C	17.5	19.0	19.5	18.0
AISLE WIDTH BETWEEN STALL LINES	D	14.0	18.0	23.0	24.0
STALL DEPTH, INTERLOCK	E	15.3	17.5	18.8	18.0
MODULE, WALL TO INTERLOCK	F	47.8	54.5	61.3	62.0
MODULE, INTERLOCKING	G	45.6	53.0	61.0	62.0
MODULE, INTERLOCK TO CURB FACE	H	46.8	53.5	60.3	61.0
TYPICAL BUMPER OVERHANG	I	1.0	1.0	1.0	1.0
CROSS AISLE, ONE-WAY	L	14.0	14.0	14.0	14.0
CROSS AISLE, TWO-WAY	L	24.0	24.0	24.0	24.0

* STALL WIDTH 9.0 FT.

VILLAGE OF LEMONT

PARKING LOT

REV. 6/23/08

12/10/01

NO. LS-7

REV. 1

SILT FENCE PLAN

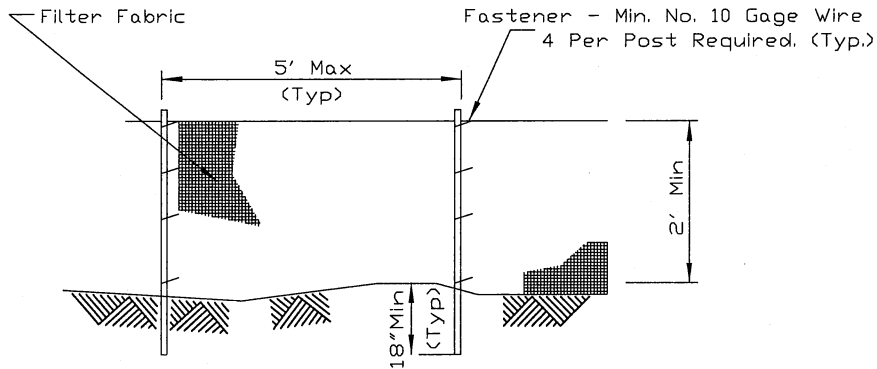

ELEVATION

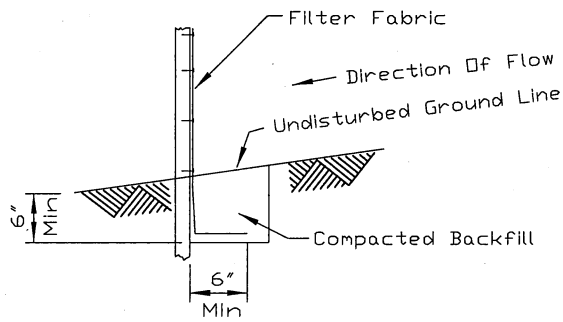

FABRIC ANCHOR DETAIL

NOTES:

1. Temporary sediment fence shall be installed prior to any grading work in the area to be protected. They shall be maintained throughout the construction period and removed in conjunction with the final grading and site stabilization.
2. Filter fabric shall meet the requirements of material specification 592 Geotextile Table 1 or 2, Class with equivalent opening size of at least 30 for nonwoven and 50 for woven.
3. Fence posts shall be either standard steel post or wood post with a minimum cross-sectional area of 3.0 sq. in.

REFERENCE	Project _____
Designed	_____ Date _____
Checked	_____ Date _____
Approved	_____ Date _____



STANDARD DWG. NO.	IL-620
SHEET	1 OF 2
DATE	11-20-01

SILT FENCE

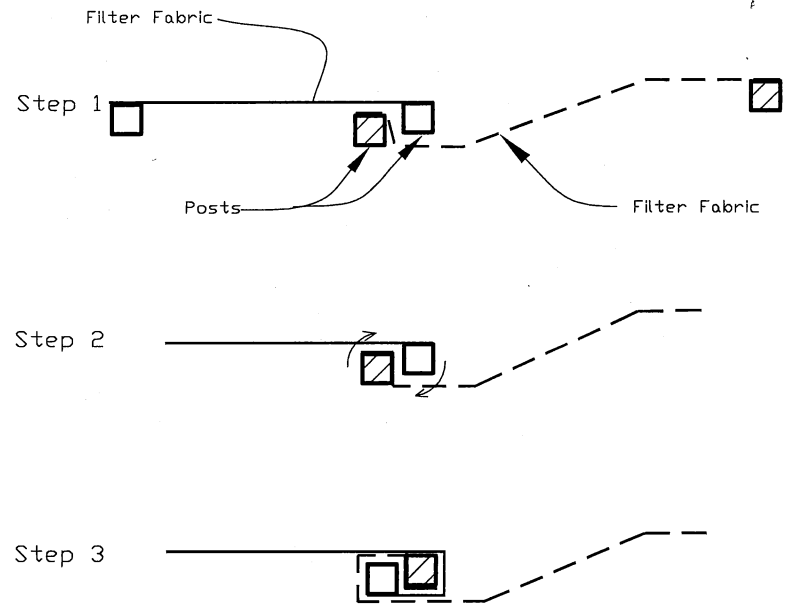

ATTACHING TWO SILT FENCES

NOTES:

1. Place the end post of the second fence inside the end post of the first fence.
2. Rotate both posts at least 180 degrees in a clockwise direction to create a tight seal with the fabric material.
3. Drive both posts a minimum of 18 inches into the ground and bury the flap.

REFERENCE	Project _____
Designed	_____ Date _____
Checked	_____ Date _____
Approved	_____ Date _____



STANDARD DWG. NO.	IL-620(W)
SHEET	2 OF 2
DATE	1-29-99

REV. 2/27/13

12/10/01

NO. LS-8

REV. 2

SILT FENCE

VILLAGE OF LEMONT

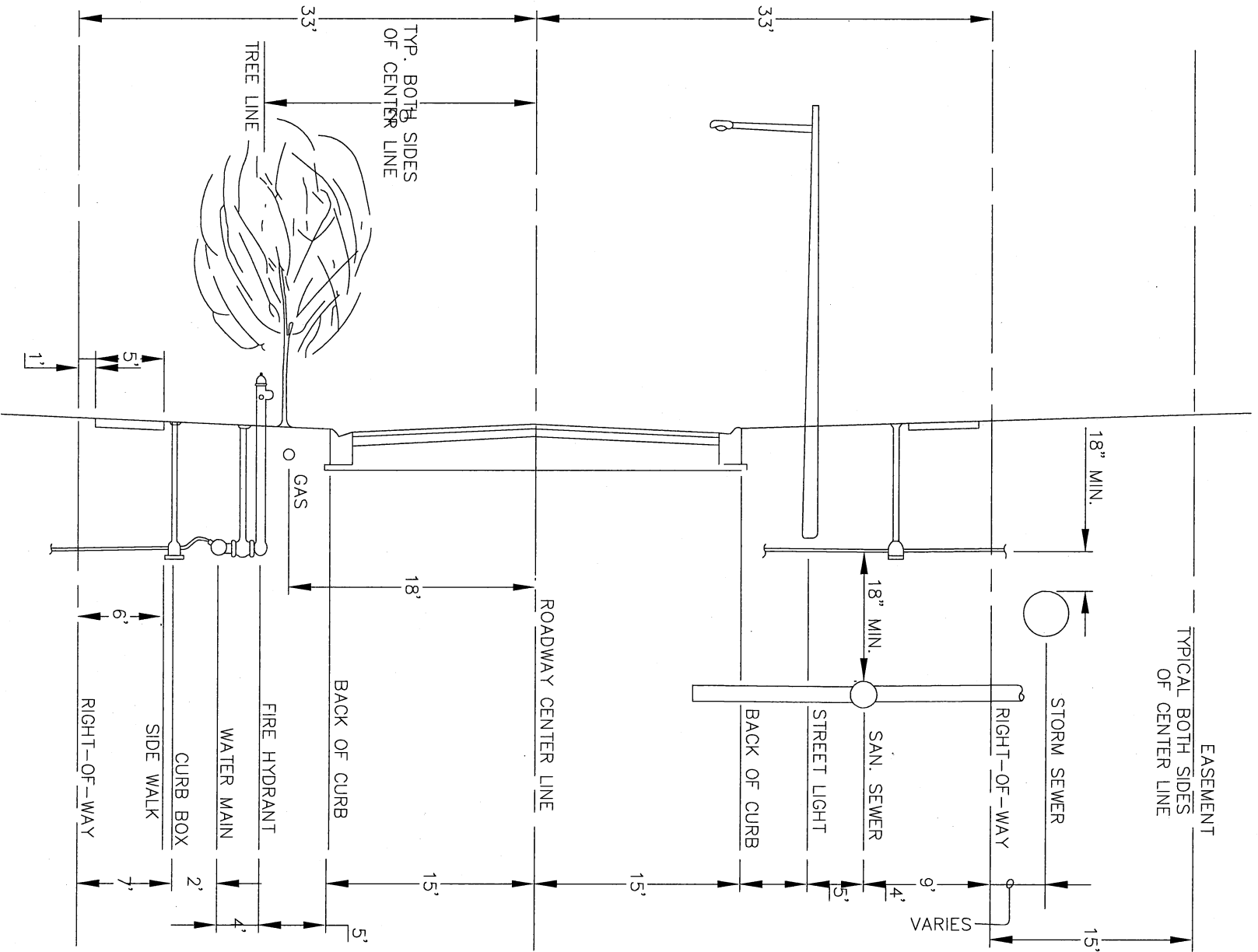

TYPICAL RESIDENTIAL RIGHT OF WAY CROSS SECTION
NOT TO SCALE

VILLAGE OF LEMONT
RESIDENTIAL RIGHT-OF-WAY

REV. 6/23/08

12/10/01

NO. LS-10

REV. 2

BACKFILL WITH EXCAVATED MATERIAL EXCEPT WHERE GRANULAR MATERIAL IS REQUIRED PROVIDE CA-6

FINISHED GRADE

ANGLE OF REPOSE SEE NOTE #3

ACTUAL TRENCH WALL

IF ENCOUNTERED, REMOVE UNSUITABLE MATERIAL AND REPLACE WITH GRANULAR MATERIAL

INSTALL WATER MAIN ON VIRGIN CLAY, WITH BELL HOLES CUT OUT.

TRENCH WIDTH SEE NOTE #2

TRENCH SECTION FOR WATER MAIN PRESSURE PIPE

(WATER MAIN)

FINISHED GRADE

BACKFILL WITH EXCAVATED MATERIAL EXCEPT WHERE GRANULAR MATERIAL IS REQUIRED PROVIDE CA-6

BEDDING 4" MINIMUM VARIES OR 1/4 PIPE DIAMETER, WHICHEVER IS GREATER

ANGLE OF REPOSE SEE NOTE #3

ACTUAL TRENCH WALL

CAREFULLY PLACED GRANULAR HAUNCHING TO SPRINGLINE

IF ENCOUNTERED, REMOVE UNSUITABLE MATERIAL AND REPLACE WITH GRANULAR MATERIAL

TRENCH WIDTH SEE NOTE #2

TRENCH SECTION FOR RIGID SEWER PIPE

(R.C.C.P. or D.I.)

NOTES:

1. BEDDING, HAUNCHING AND COVER TO BE (CA-11 or CA-13)
2. TRENCH WIDTH SHALL BE AS NARROW AS POSSIBLE, WITH MINIMUM WIDTH OF PIPE O.D. PLUS 8" EACH SIDE
3. ANGLE OF REPOSE AS CALCULATED BY OSHA FOR SLOPING EXCAVATIONS OF VARIOUS TYPES OF SOIL (AVG. SOIL OF SLOPE). NOTE THAT PORTABLE TRENCH BOXES OR SLIDING TRENCH SHIELDS MAY BE USED IN LIEU OF SLOPING.

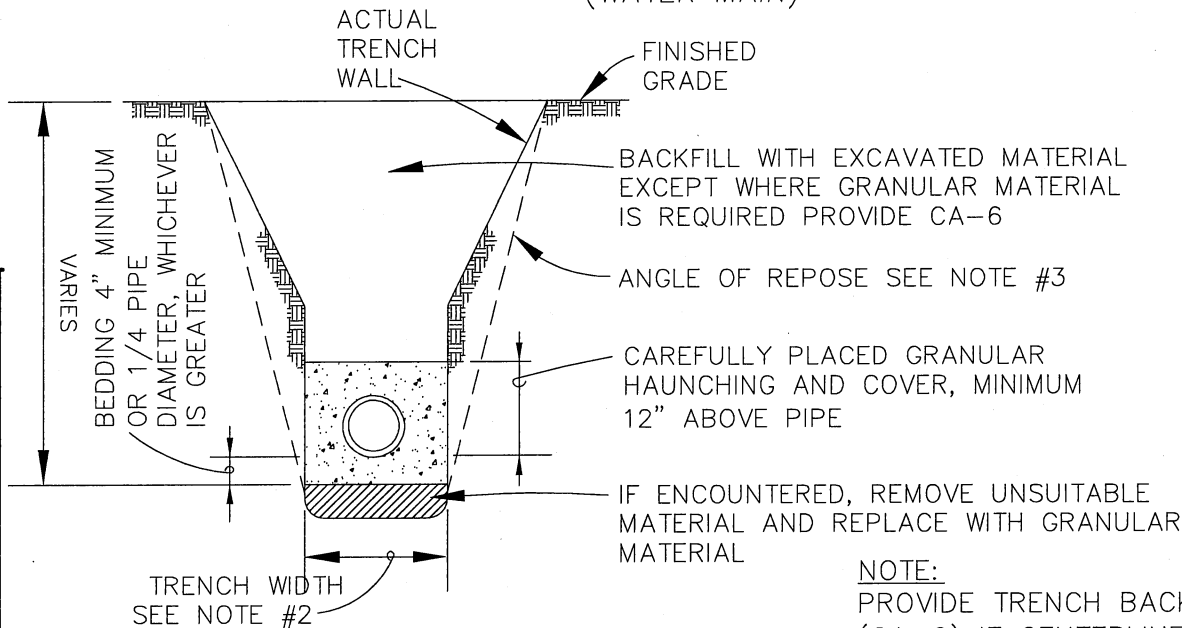

TRENCH SECTION FOR FLEXIBLE SEWER PIPE

(P.V.C. OR HDPE)

NOTE:
 PROVIDE TRENCH BACKFILL (CA-6) IF CENTERLINE OF PIPE IS WITHIN 5 FEET OF BACK OF CURB OR OTHER PAVED AREAS. INCLUDING SIDEWALK

REV. 6/23/08

12/10/01 NO. LS-20

REV. 2

**VILLAGE OF LEMONT
 BEDDING AND BACKFILL**

2-#8 THRU 12"
 2-#10 FOR 14" THRU 18"
 SPECIAL DESIGN FOR
 LARGER THAN 18"

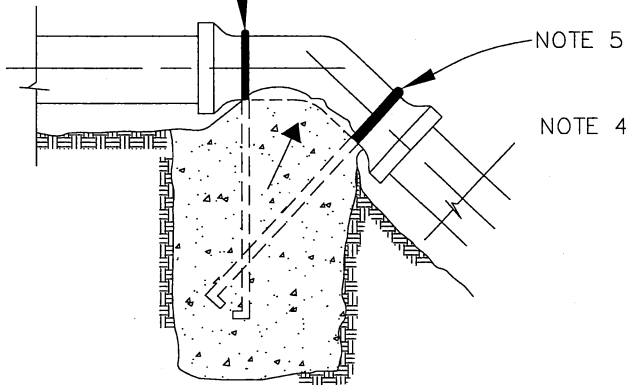

VERTICAL BEND

NOTE 5

NOTE 4

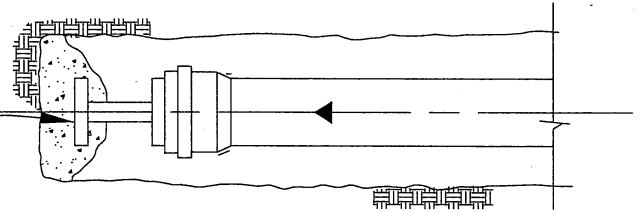

DEAD END

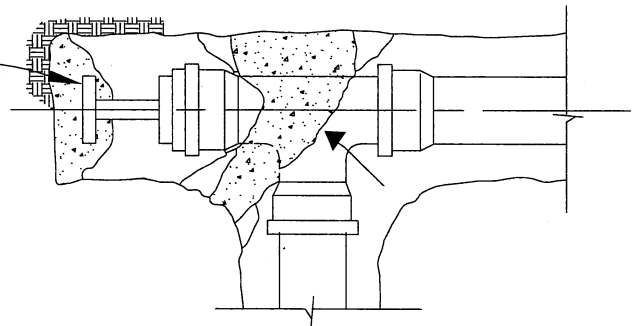

PLUGGED TEE

NOTE 4

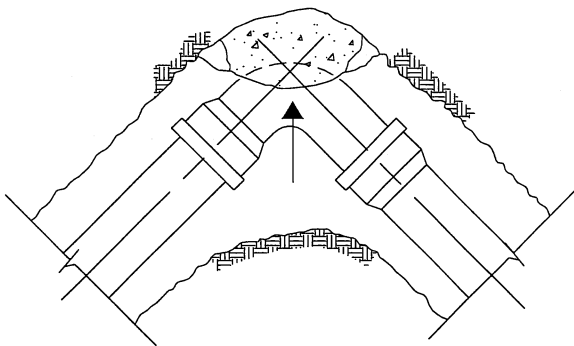

HORIZONTAL BEND

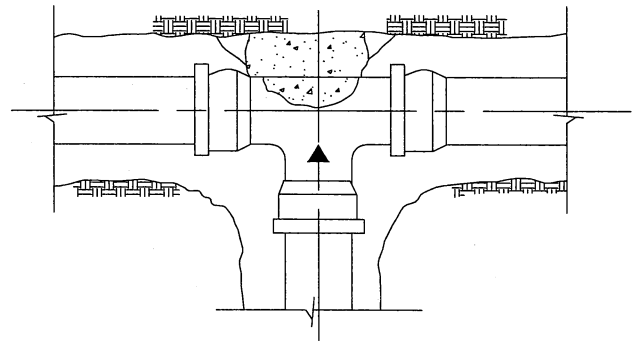

TEE

MEGALUG 1000 OR 1000SD SERIES RESTRAINING SYSTEM SHALL ALSO BE REQUIRED AT ALL THRUST BLOCK LOCATIONS, AS SUPPLEMENTAL PROTECTION

NOTES:

1. ALL BLOCKS TO BE SOLID CAST-IN-PLACE CONCRETE EXCEPT AT VERTICAL BEND.
2. ALL BLOCKS TO BEAR AGAINST UNDISTURBED EARTH, AND BE 12" MINIMUM THICKNESS
3. ARROWS INDICATE DIRECTION OF THRUST.
4. 3" STANDARD WEIGHT STEEL PIPE W/ 3/8"x6"X0'-6 STEEL PLATES.
5. COAT EXPOSED PORTION OF BARS WITH BITUMASTIC COMPOUND.

VILLAGE OF LEMONT

THRUST BLOCKS

REV. 6/23/08

12/10/01

NO. LS-21

REV. 2

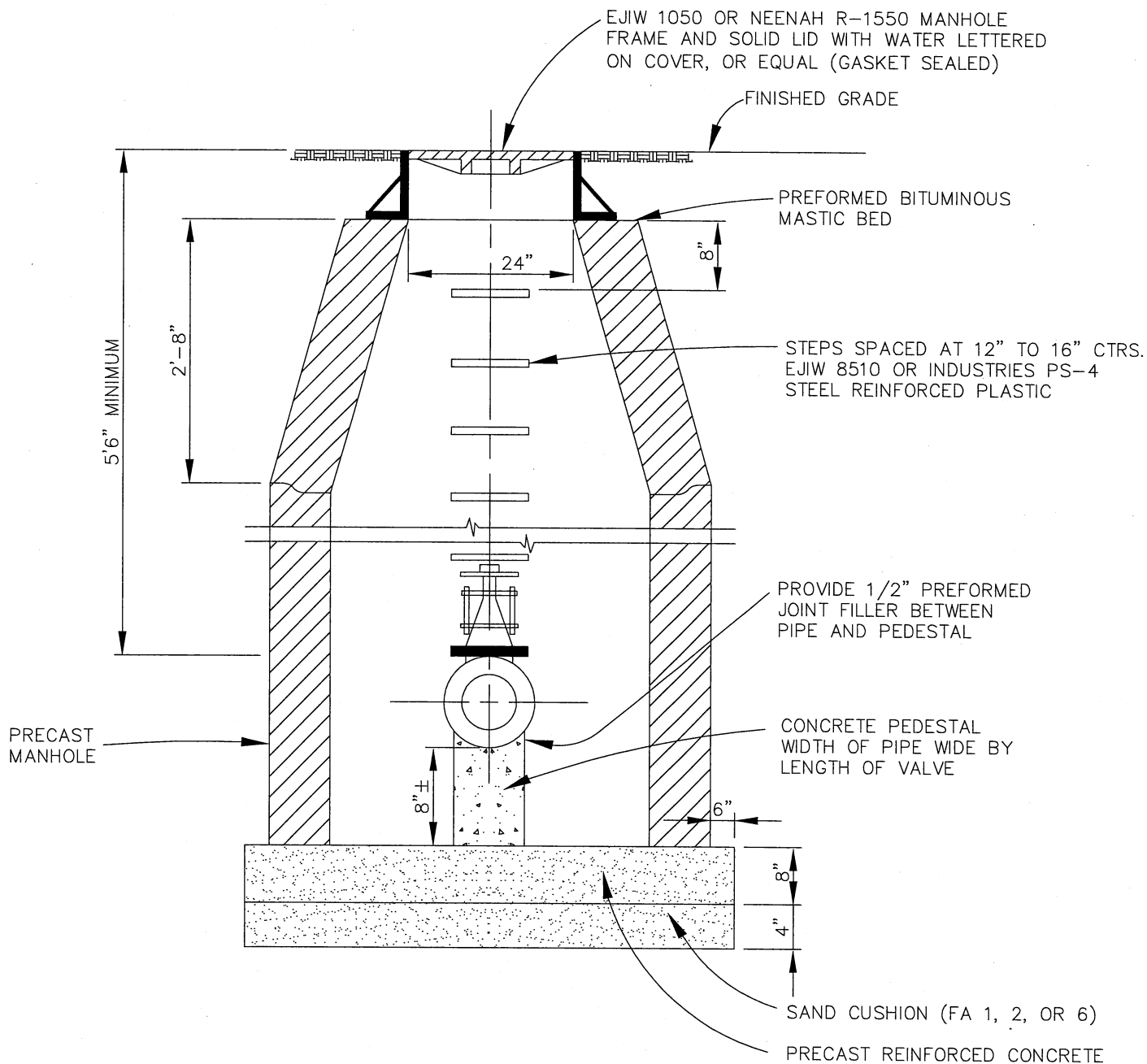

NOTES:

1. NO MORE THAN TWO ADJUSTING RINGS FOR A TOTAL 6" OF ADJUSTMENT MAY BE USED
2. VALVES MUST ALIGN WITH CENTER OF VAULT OPENING
3. VALVE VAULT DIAMETER SHALL BE 5 FOOT FOR 12" VALVES AND PRESSURE CONNECTIONS OF 8" DIAMETER AND LARGER
4. CONES MUST BE CONCENTRIC

VILLAGE OF LEMONT

WATER VALVE VAULT

REV. 6/23/08

12/10/01

NO. LS-22

REV. 1

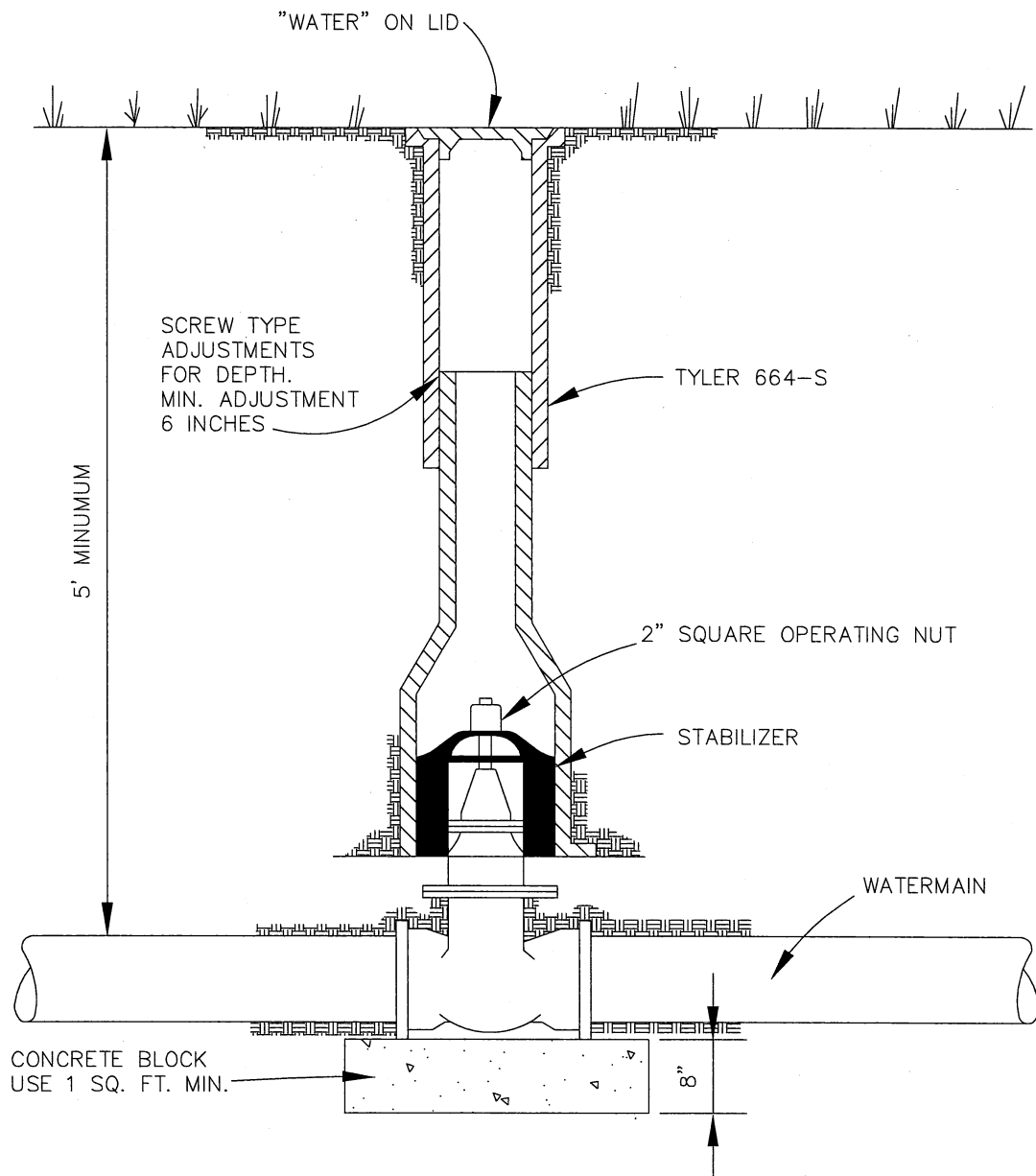

VILLAGE OF LEMONT		
VALVE BOX		
REV. 6/23/08	12/10/01	NO. LS-23
		REV. 2

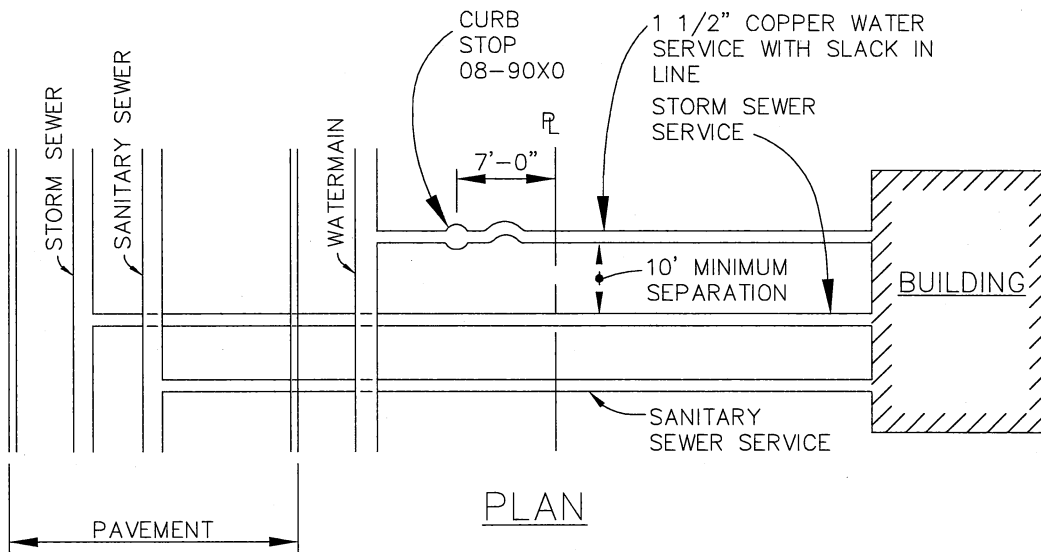

PLAN

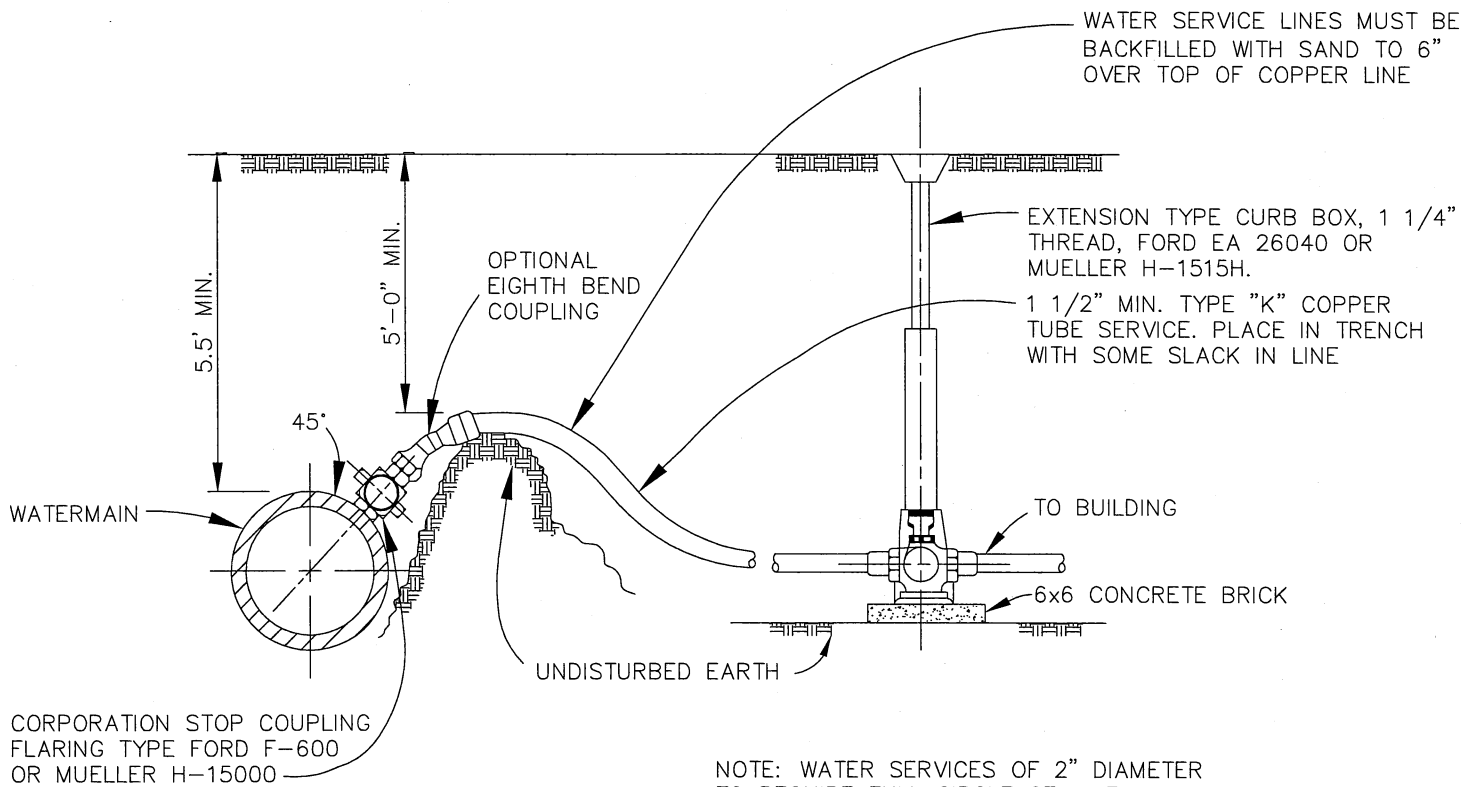

NOTE: WATER SERVICES OF 2" DIAMETER TO REQUIRE FULL CIRCLE STAINLESS STEEL TAPPING SADDLES, MUELLER "SS" SERIES OR APPROVED EQUAL

NOTES:

1. TAPS AT ANGLES UP TO 90° WILL BE PERMITTED IF CONDITIONS DO NOT ALLOW TAPPING AT 45°.
2. TAPS MUST BE MADE 3 FEET FROM THE BELL OF THE PIPE WHERE TWO OR MORE TAPS ARE MADE, THEY MUST BE 18" APART.
3. SEWER SEPARATION REQUIREMENTS MUST BE SATISFIED IN ALL CASES.
4. CURB STOP COVER SHALL BE FLUSH WITH FINISHED GRADE.
5. CURB STOP SHALL NOT BE IN DRIVEWAY.
6. CURB STOP IS WITH COMPRESSION COUPLING FORD B44-444 FOR 1 1/2" FLARED COPPER, OR MUELLER EQUAL.
7. CURB STOP LID HAS 1 1/2" THREADED BRASS PENTAGON PLUG WITH WORD "WATER" IN RAISED LETTERS.

VILLAGE OF LEMONT

WATER SERVICE CONNECTION

REV. 6/23/08

12/10/01

NO. LS-24

REV. 2

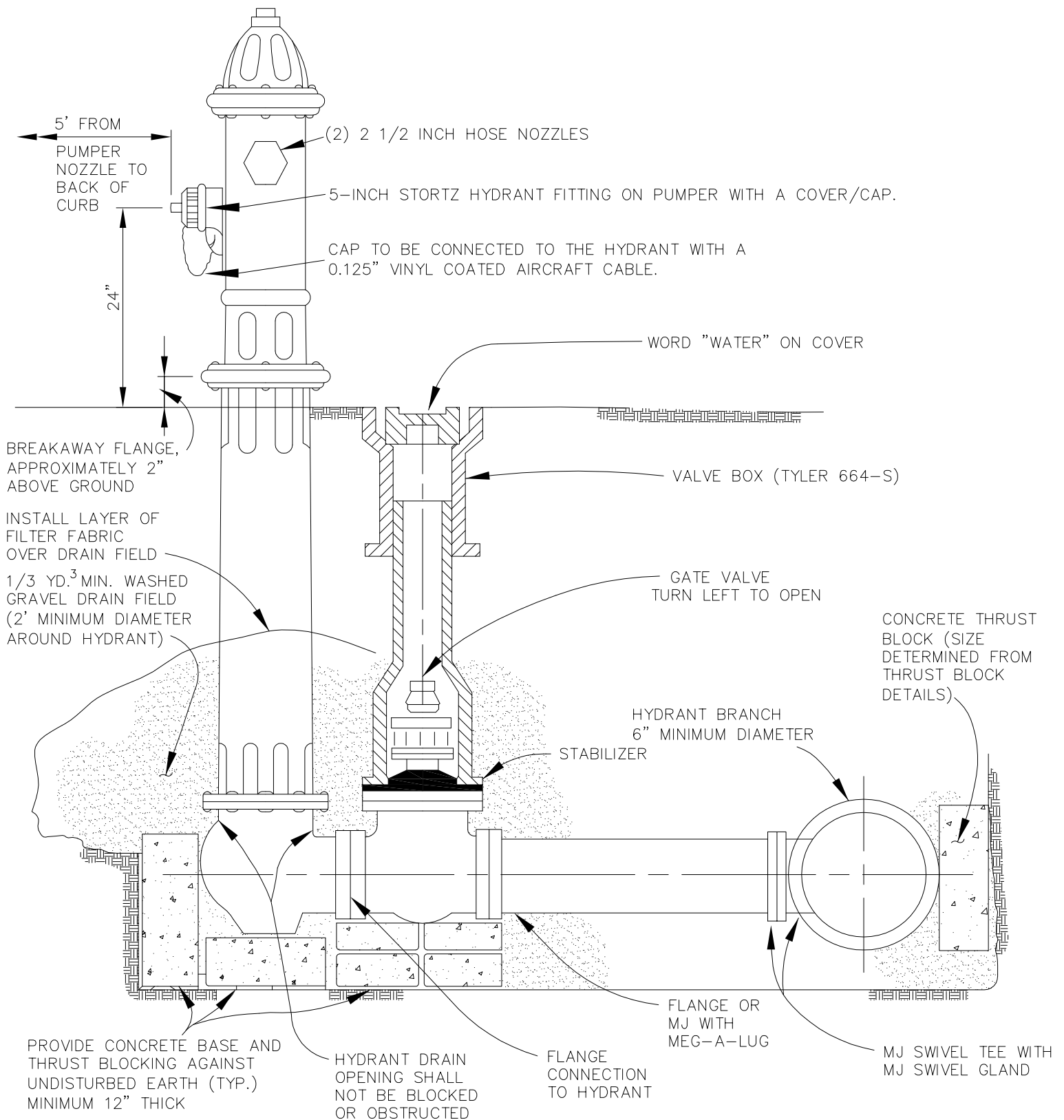

NOTES:

1. HYDRANT TO HAVE A BREAKAWAY FLANGE
2. HYDRANT TO BE PAINTED TNE MEC GLOSS SAFETY GREEN
3. CONFORM TO AWWA C-502 EAST JORDAN 5BR-250, OR CLOW MEDALLION
4. HYDRANT VALVE TO BE SAME MANUFACTURER AS HYDRANT

REV. 4/07/14
 REV. 1/08/10
 REV. 5/12/09
 REV. 6/23/08

VILLAGE OF LEMONT		
HYDRANT AND VALVE		
12/10/01	NO. LS-25	REV. 4

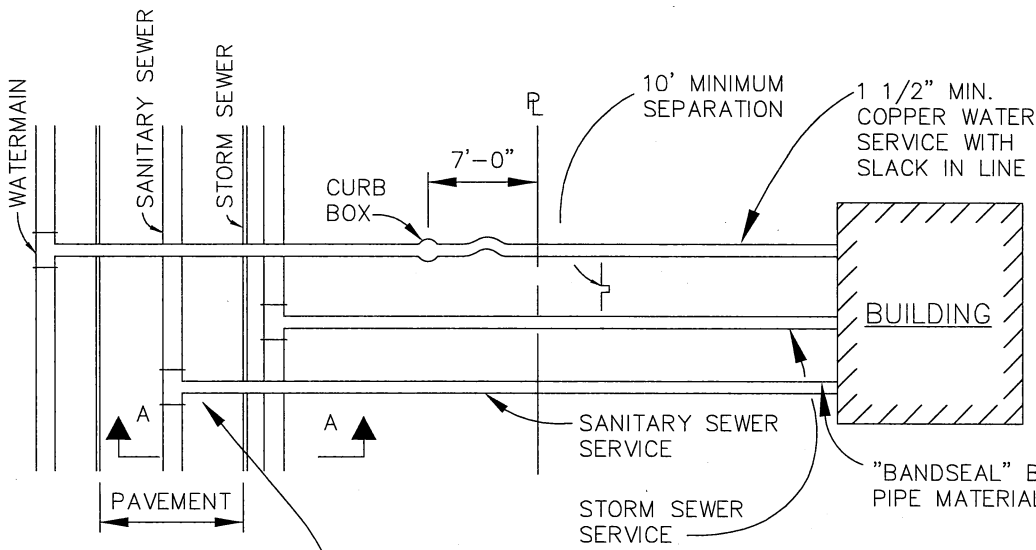

PLAN VIEW

NOTE: 10" MINIMUM SEPARATION TO BE MAINTAINED IN ALL CASES. NO EXCEPTIONS ALLOWED.

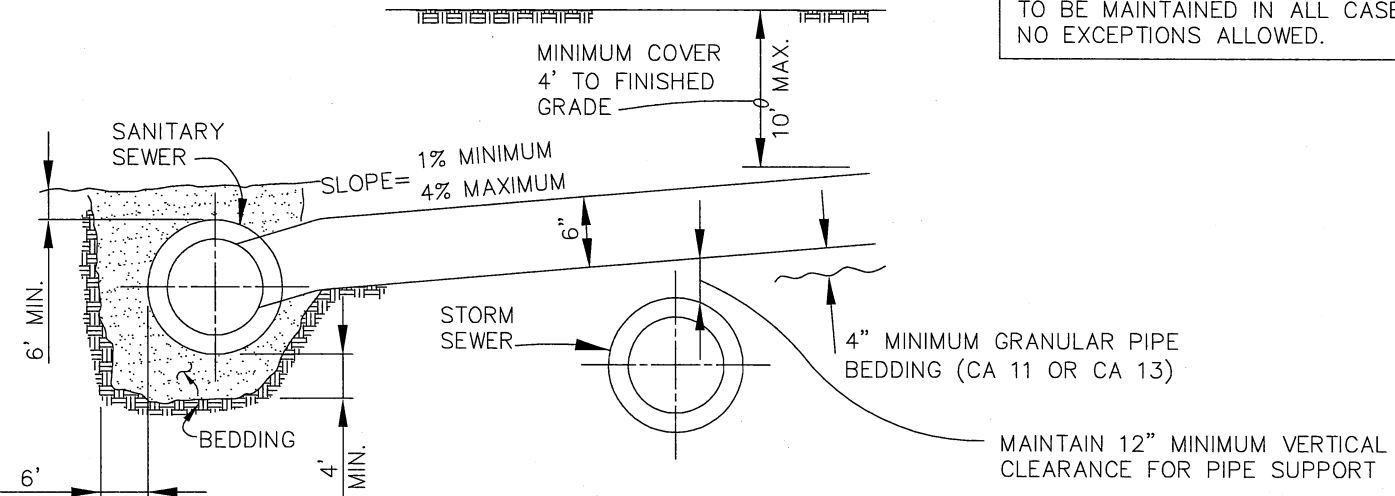

SECTION A-A

NOTES:

1. NO SEWER CONECTION THAT WOULD INTRODUCE STORM WATER, RAIN WATER, SURFACE OR ROOF RUNOFF, GROUND WATER SEEPAGE FROM TILE DRAIN, LIQUID PETROLEUM PRODUCTS OR FLAMMABLE LIQUIDS INTO THE SANITARY SEWER WILL BE ALLOWED.
2. ALL CROSSINGS OF WATER AND SEWER MUST BE IN ACCORDANCE WITH SEWER AND WATER SEPERATION REQUIREMENTS OF THE ILLINOIS EPA.
3. TRENCH CUTS TO BE RESTORED TO EXISTING CONDITIONS. DRIVEWAY, STREET OR SIDEWALK CROSSINGS TO BE FILLED TO THE SURFACE WITH COMPACTED GRANULAR MATERIAL, CA6. SEE TRENCH CUT RESTORATION DETAIL.
4. CONNECTION TO MAIN BY WYE OR SEWER TAP WITH METAL SLEEVE.
5. FERNCO (OR EQUAL) TYPE COUPLING SHALL BE USED IN THE CONNECTION OF SEWER PIPES OF DISSIMILAR MATERIALS.

MATERIAL ALLOWED

MATERIAL	PIPE SPEC.	JOINT SPEC.
6" P.V.C. PIPE SDR 26, PR	ASTM D-2241	ASTM D-3139
6" DUCTILE IRON PIPE CLASS 52, COATED OR CEMENT LINED	AWWA C151	AWWA C-111

VILLAGE OF LEMONT
SANITARY SEWER SERVICE
CONNECTION

REV. 6/23/08

12/10/01

NO. LS-40

REV. 2

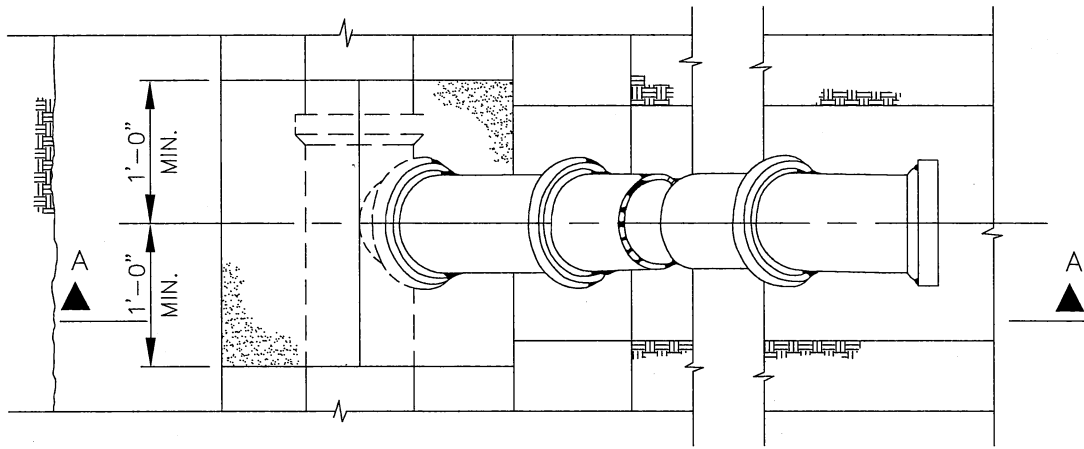

PLAN

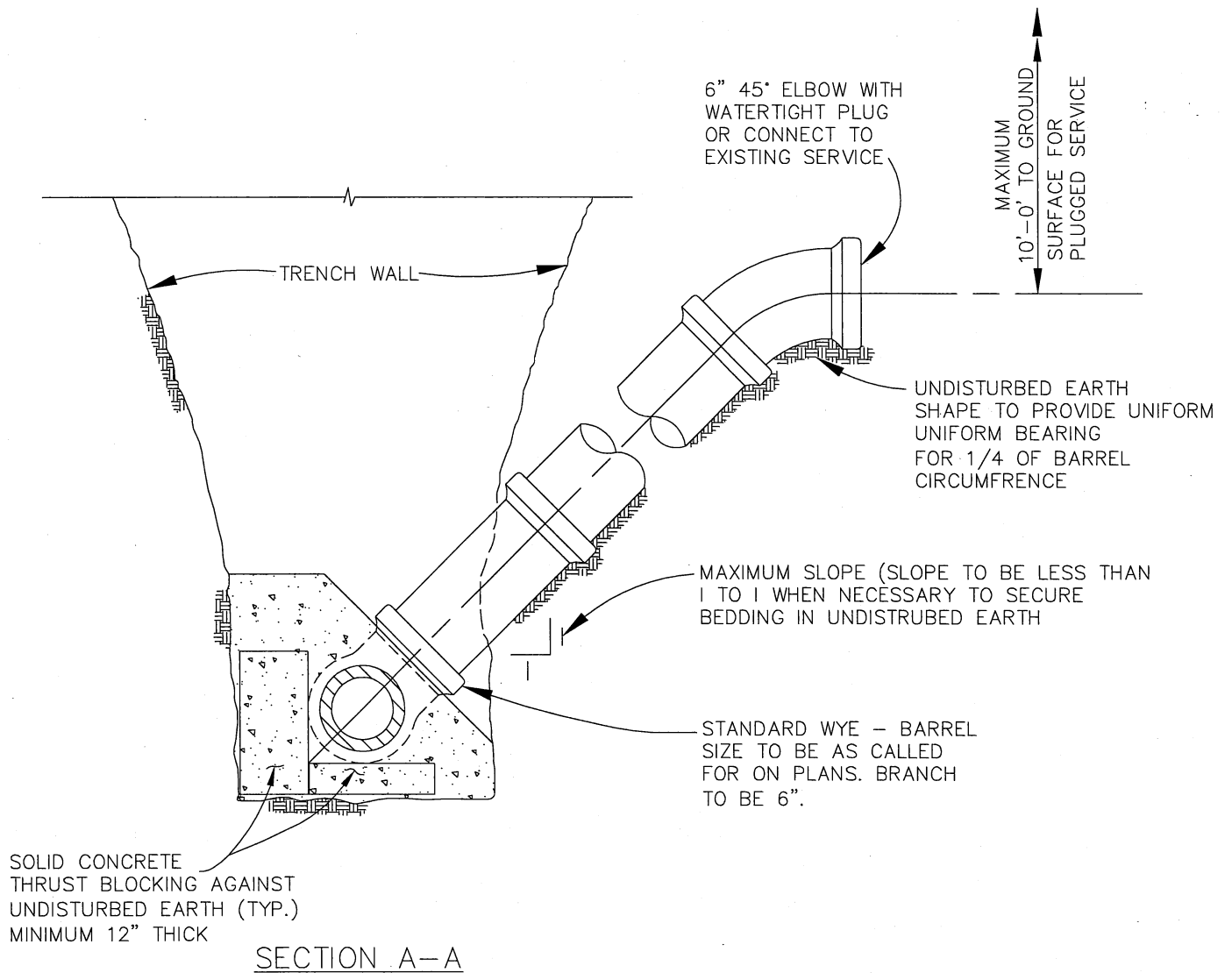

VILLAGE OF LEMONT

SANITARY SERVICE RISER

REV. 6/23/08

12/10/01

NO. LS-41

REV. 1

NOTES:

1. STEPS SHALL CONFORM TO THE REQUIREMENTS OF THE IDOT STANDARD SPECIFICATIONS.
2. PROVIDE CA-6 AGGREGATE BACKFILL AROUND MANHOLE TO SUBGRADE ELEVATION IN PAVED AREAS.
3. CASTINGS TO BE AS SPECIFIED IN THE STANDARD SPECIFICATIONS.
4. MANHOLE COVER SHALL BE EJIW NO. 1050 OR NEENAH R-1550 AND HAVE 2" RAISED LETTERS:
"SANITARY" AND "VILLAGE OF LEMONT"

NOTE: PROVIDE INTERIOR CHIMNEY SEALS (CRETEX OR EQUAL) AT ALL SANITARY SEWER MANHOLES TO PREVENT INFILTRATION. USE 3/16" RUBBER SLEEVE (ASTM C923) WITH 1 1/4" STAINLESS STEEL COMPRESSION BANDS (ASTM C240)

R-1550 WITH SELF SEALING TYPE A HEAVY DUTY LID AND GASKET SEALED WITH CONCEALED PICKHOLES

PRECAST CONC. OR RUBBER COMPOSITE ADJUSTING RINGS (2 MAXIMUM)

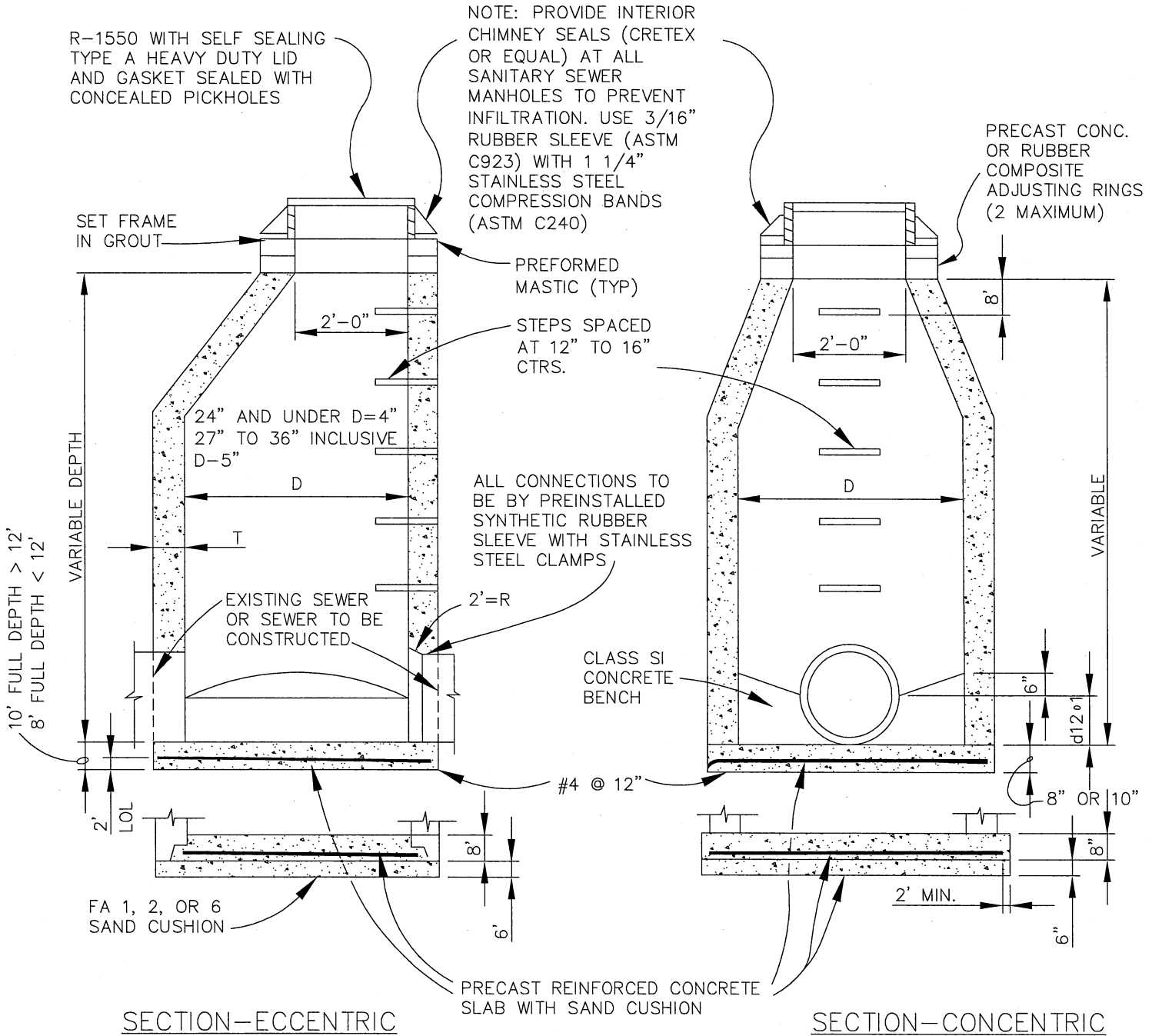

SECTION-ECCENTRIC

SECTION-CONCENTRIC

FOR DIAMETER, D= 4 ft. THICKNESS, T= 5 in.
 5 ft. 6 in.
 6 ft. 6 in.

VILLAGE OF LEMONT		
SANITARY MANHOLE		
12/10/01	NO. LS-42	REV. 2

REV. 6/23/08

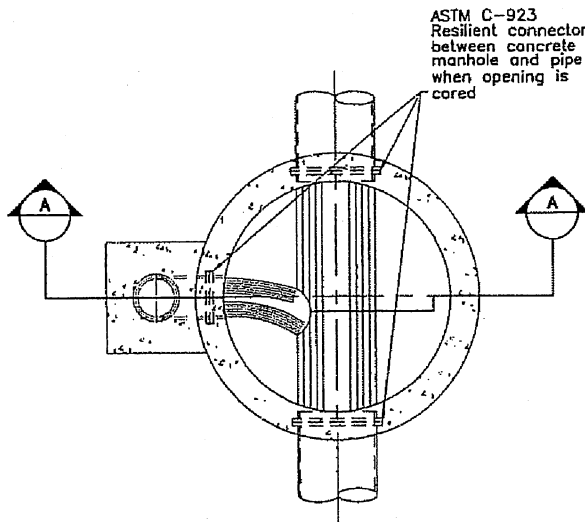

Section C-C

D ₁ (inches)	D ₂ (inches)
6	8
8	8
10	8
12	8
15	10
18	12
21	15
24	18

Notes:

D₂ shall be no smaller than two (2) nominal diameters less than D₁, but not less than 8".

Details and material for drop manhole shall be same as for standard manhole except for lateral sewer connection as shown.

Manhole to be cast-in-place concrete or Type "A" w/ precast concrete sections and bottom (as shown).

Invert of elbow to be placed even with the level of the bench.

Minimum wall thickness "t" for for drop manhole:
 a. 6" for cast-in-place concrete
 b. 1/12 manhole diameter for precast concrete.

Concrete for encasement shall be 3000 psi @ 28 days, minimum.

Manhole steps are omitted for clarity.

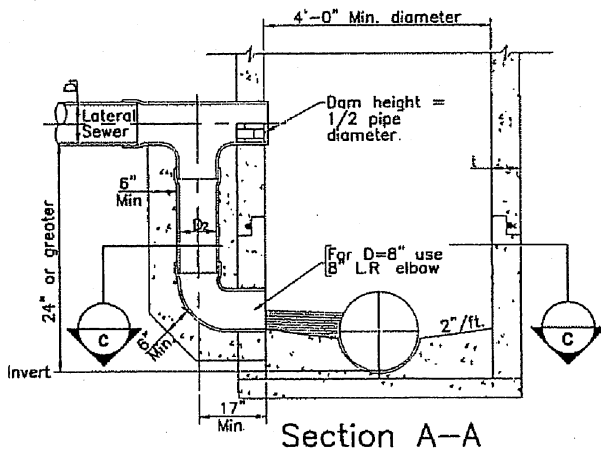

Section A-A

Standard Drop Manhole

METROPOLITAN WATER RECLAMATION
 DISTRICT OF GREATER CHICAGO
 ENGINEERING DEPARTMENT
 10-02 Local Sewer Systems JRR:SDO

VILLAGE OF LEMONT

DROP PIPE ASSEMBLY

REV. 6/23/08

12/10/01

NO. LS-43

REV. 1

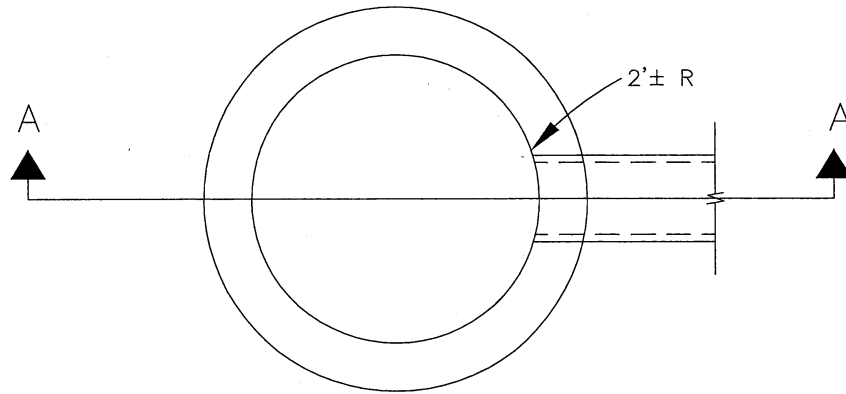

PLAN

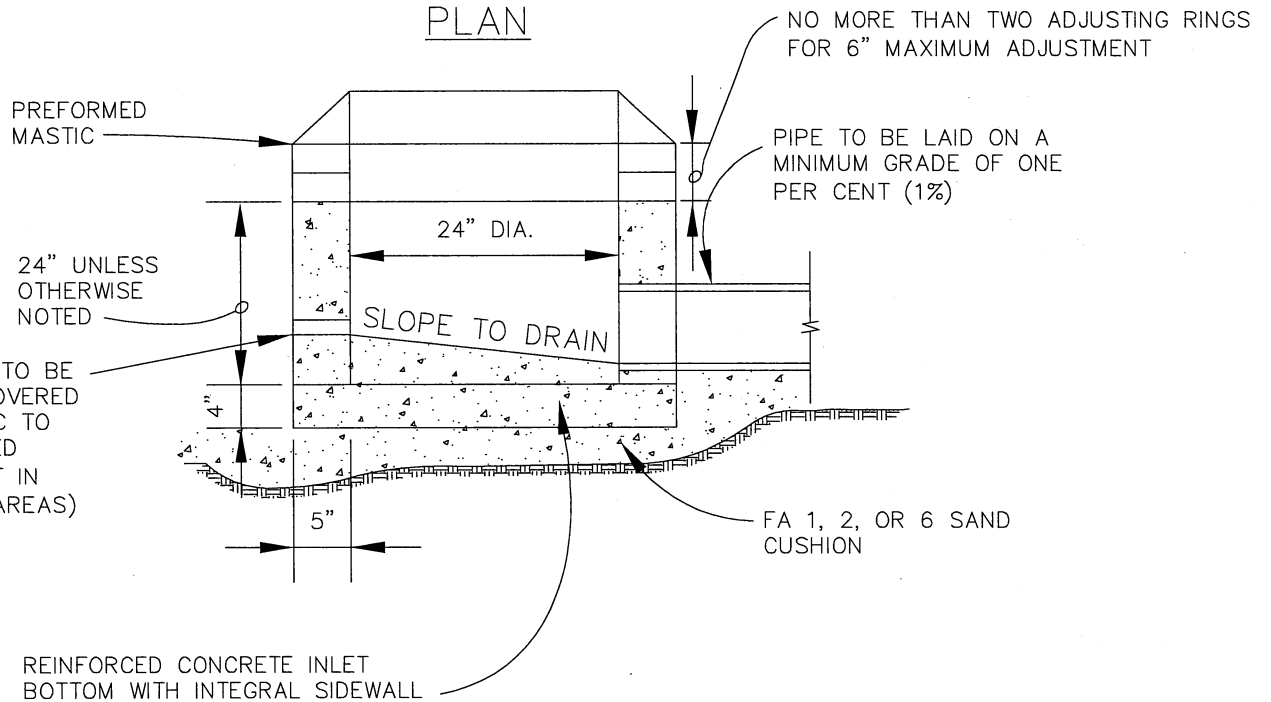

SECTION A-A

NOTE:

1. PROVIDE CA-6 AGGREGATE BACKFILL AROUND INLET TO SUBGRADE ELEVATION IN PAVED AREAS AND DETENTION AREAS
2. ALL CASTINGS SHALL INCORPORATE THE "DRAINS TO RIVERS" LOGO PER STANDARD NO. LS-71 OR LS-73 (OR APPLICABLE)

VILLAGE OF LEMONT

INLET, TYPE A

REV. 6/23/08

12/10/01

NO. LS-60

REV. 2

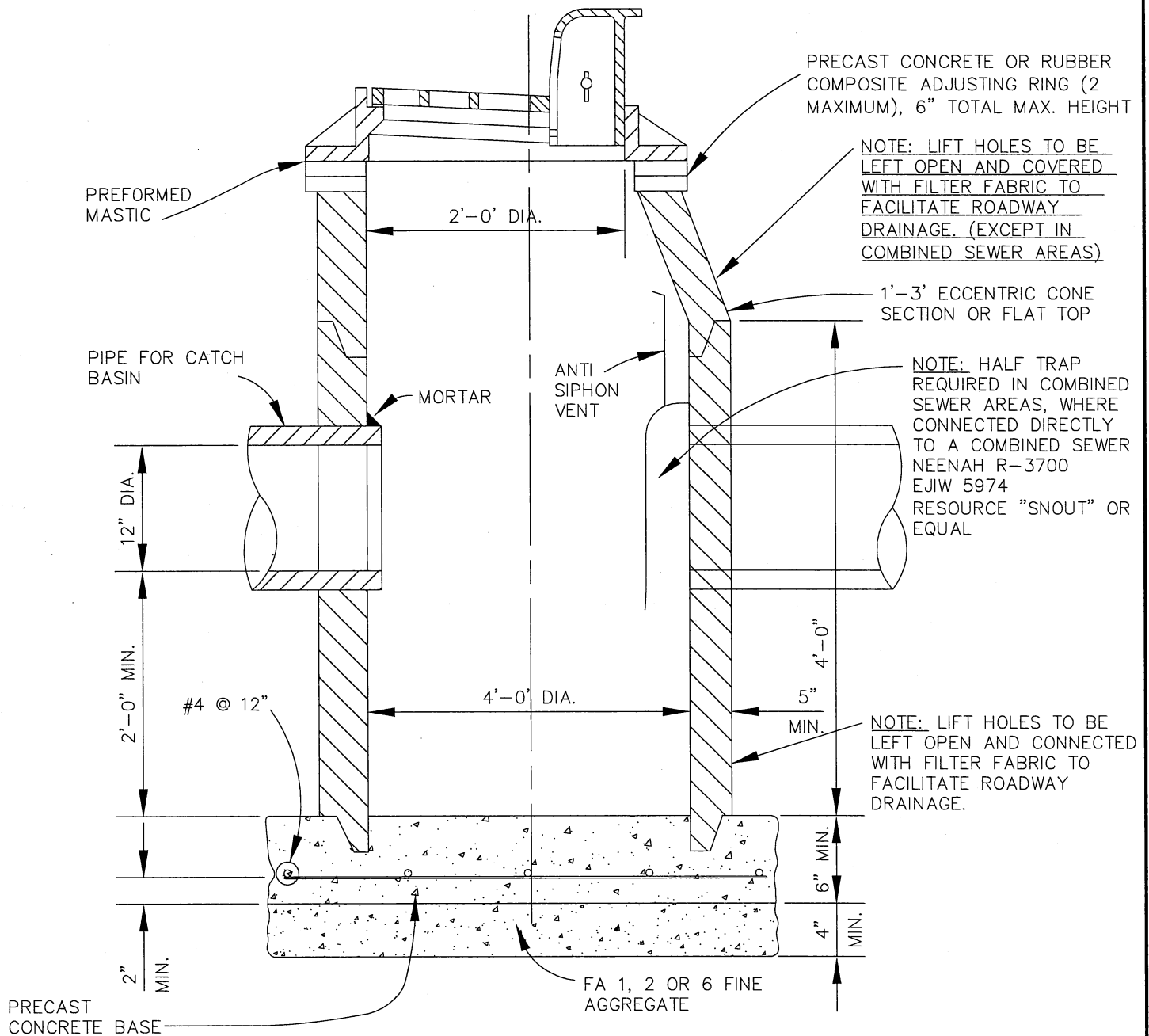

NOTES:

1. PROVIDE CA-6 AGGREGATE BACKFILL AROUND CATCH BASIN TO SUBGRADE ELEVATION.
2. CATCH BASINS ARE TO BE USED IN PAVED AREAS ONLY. FOR PRECAST REINFORCING FOR FLAT SLAB TOPS SEE I.D.O.T. STANDARD 2354-1.
3. FRAME AND GRATE EAST JORDAN 7210, NEENAH R-3281 A OR EQUAL FOR STANDARD BARRIER CURB AND EAST JORDAN 7525 OR NEENAH R-3501 P, OR EQUAL FOR ROLLED CURB. NEENAH R-3281-AL FOR VANED GRATE USE.
4. ALL CASTINGS SHALL INCORPORATE THE "DRAINS TO RIVERS" LOGO PER STANDARD NO. LS-71

VILLAGE OF LEMONT		
CATCH BASIN TYPE A		
12/10/01	NO. LS-61	REV. 1

REV. 6/23/08

NOTES:

PROVIDE CA-6 AGGREGATE BACKFILL AROUND MANHOLE TO SUBGRADE ELEVATION IN PAVED AREAS.
LIFT HOLES ON MANHOLES TO BE SEALED WITH CONCRETE PLUG AND MASTIC.

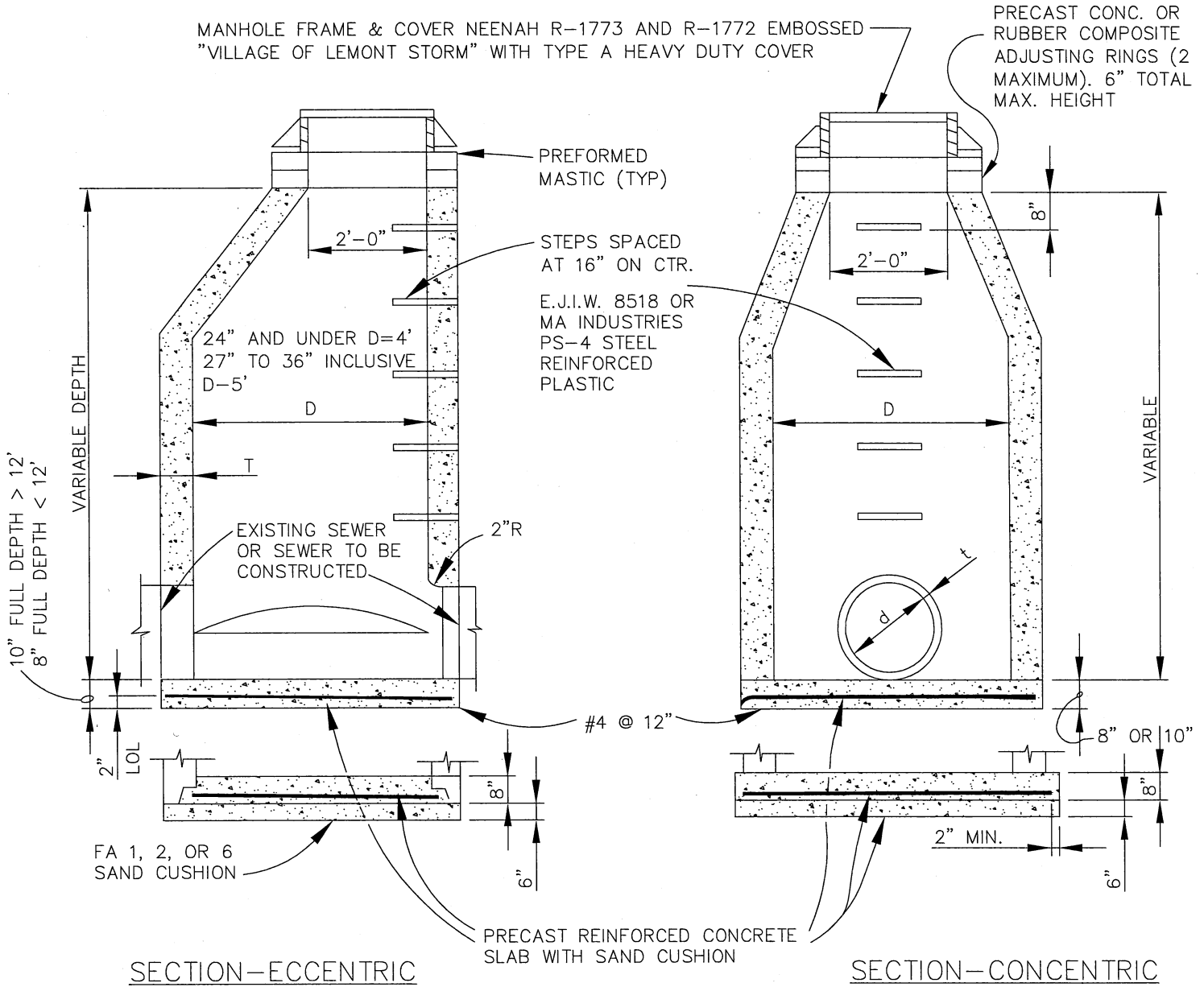

FOR DIAMETER, D= 4 ft. THICKNESS, T= 5 in.
5 ft. 6 in.
6 ft. 6 in.

VILLAGE OF LEMONT		
STORM MANHOLE		
12/10/01	NO. LS-62	REV. 1

REV. 6/23/08

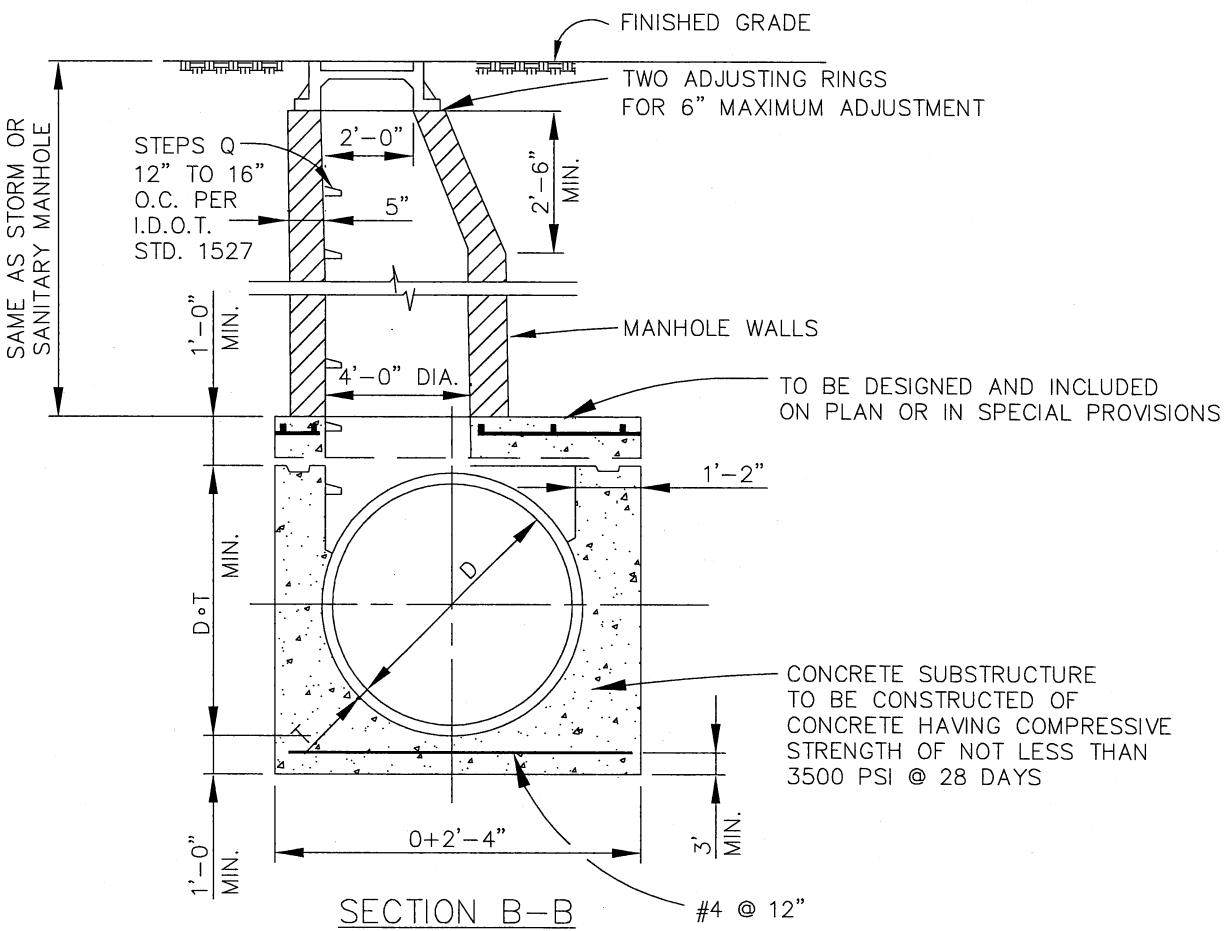
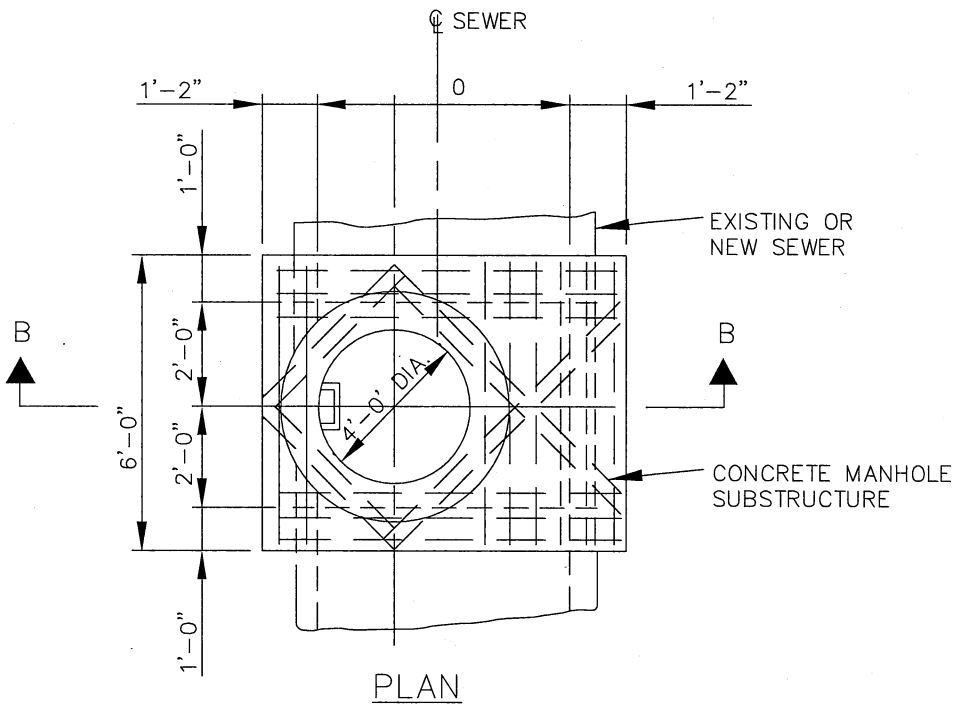

NOTE:

1. PROVIDE CA-6 AGGREGATE BACKFILL AROUND MANHOLE TO SUBGRADE ELEVATION IN PAVED AND DETENTION AREAS.

VILLAGE OF LEMONT		
STORM WATER MANHOLE FOR SEWERS LARGER THAN 42"		
12/10/01	NO. LS-63	REV. 1

REV. 6/23/08

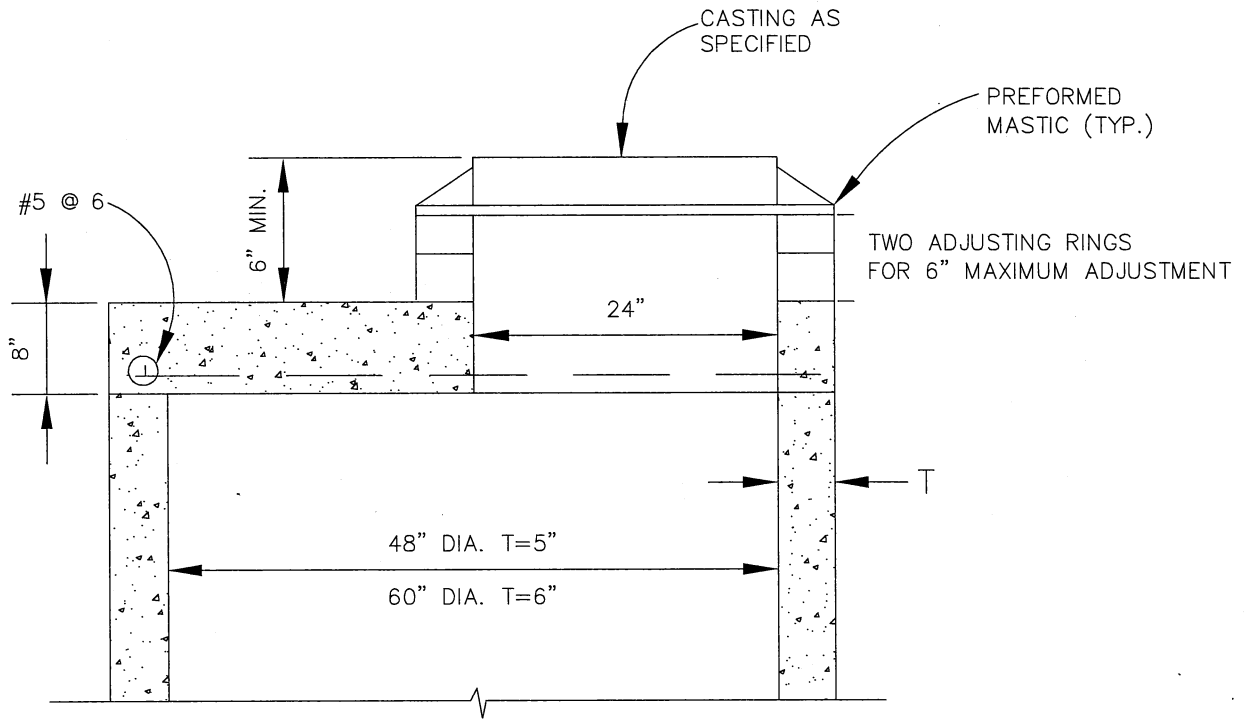

FLAT SLAB TOP FOR STORM MANHOLE

NOTE:

1. FOR PRECAST REINFORCING FOR FLAT SLAB TOPS FOR MANHOLES, CATCH BASINS, AND VALVE VAULTS. SEE IDOT STANDARD 2354-1

VILLAGE OF LEMONT		
FLAT SLAB MANHOLE TOP		
REV. 6/23/08	12/10/01	NO. LS-64
		REV. 1

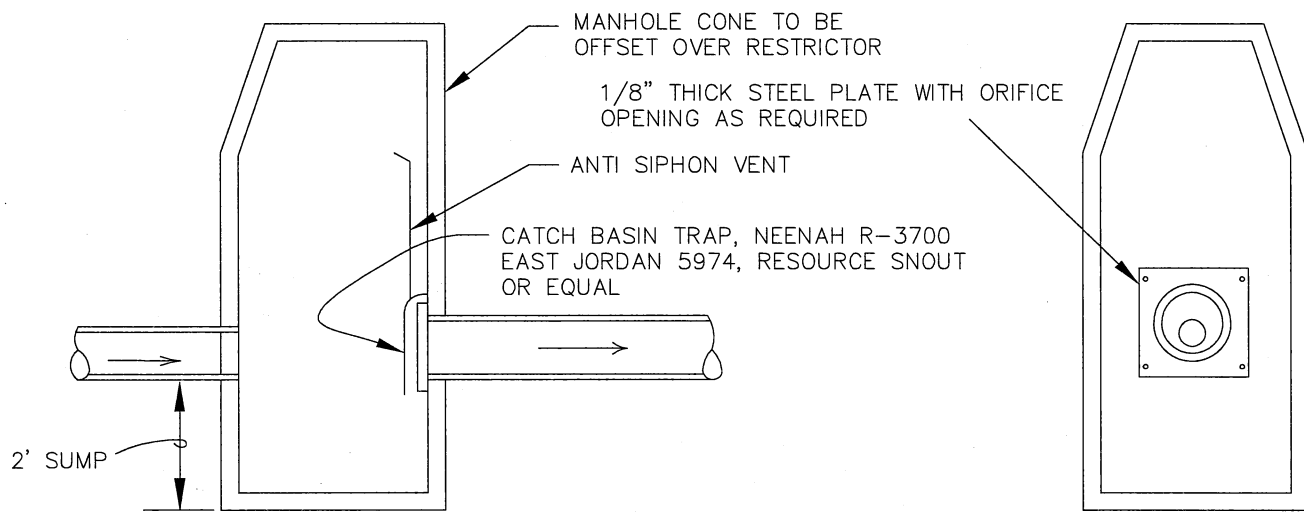

MANHOLE OR CATCH BASIN WITH RESTRICTOR PLATE

NOTES:

1. ORIFICE PLATE IS TO BE CURVED TO CONFORM WITH WALL OF CATCH BASIN
2. PROVIDE GASKET BEHIND PLATE AND CAULK PERIMETER FOR WATERTIGHT SEAL
3. PROVIDE 3/8" ANCHORS AND BOLTS TACK WELDED TO ORIFICE PLATE
4. RESTRICTORS MAY NOT BE INSTALLED IN FLARED END SECTION

VILLAGE OF LEMONT		
STORM WATER RESTRICTOR		
12/10/01	NO. LS-65	REV. 1

REV. 6/23/08

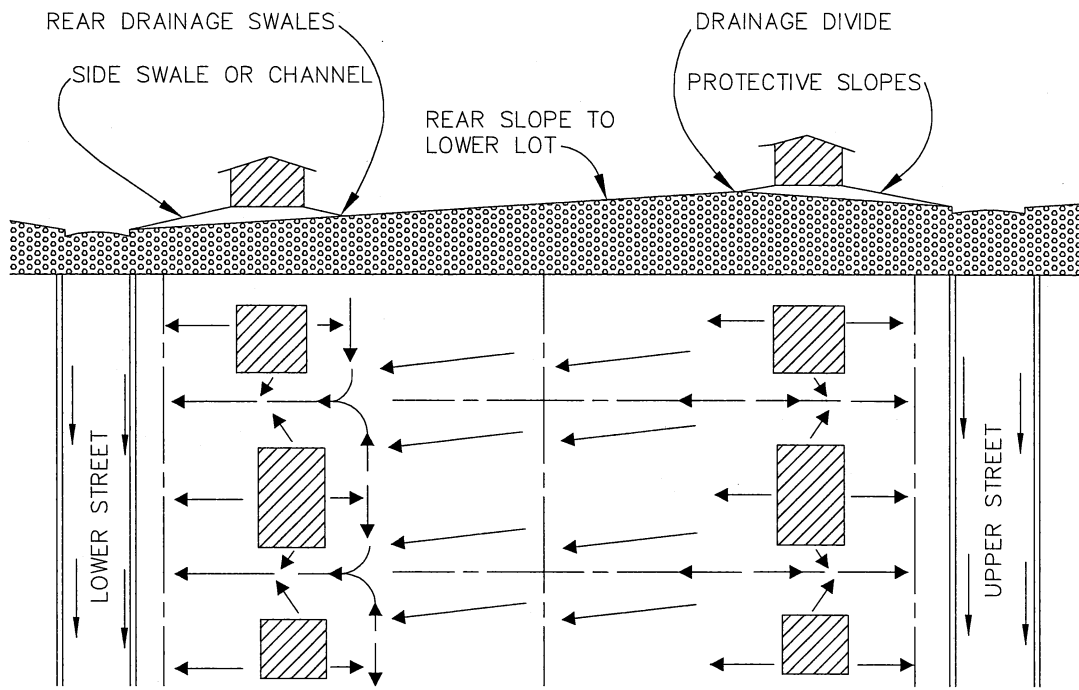

GENTLE CROSS SLOPE

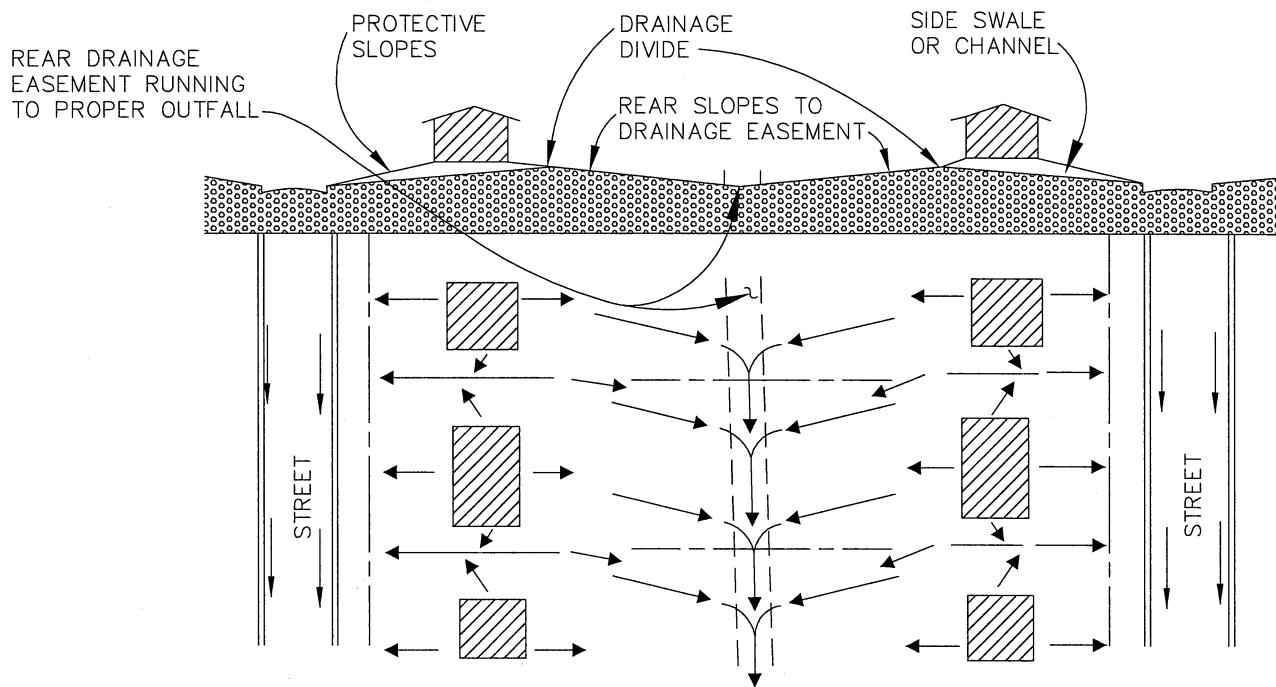

REAR LOT LINE DRAINAGE

NOTES:

1. MINIMUM 2% SLOPE
2. MAX. 25% (4:1)

VILLAGE OF LEMONT

TYPICAL RESIDENTIAL GROUPING

REV. 6/23/08

12/10/01

NO. LS-66

REV. 1

A FLEXIBLE WATER TIGHT BOOT CONFORMING TO ASTM C-933 SHALL BE CAST IN THE CATCH BASIN CATCH AREA AND FABRICATED TO BE USED IN THE BEST FORM STRUCTURE AND WREATH AND REASTM PVC-SDM AS TYPICAL - CONNECTING PIPES CONNECTION PIPE CONNECTIONS TO EXISTING SEWER PIPES EXISTING SEWER PIPES SHALL BE REQUIRED - SEAL AS REQUIRED.

LIFT HOLES TO BE LEFT OPEN AND COVERED WITH FILTER FABRIC TO FACILITATE ROADBED DRAINAGE (EXCEPT IN COMBINED SEWER AREAS)

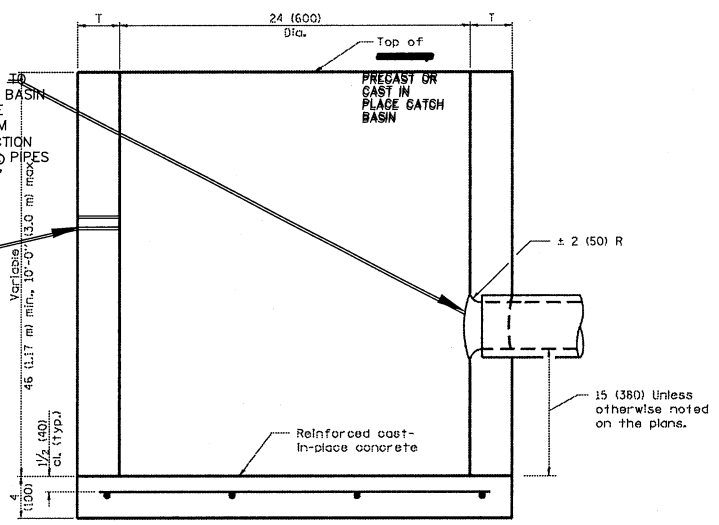

ELEVATION

ALTERNATE MATERIALS FOR WALLS	T (min)
Precast Reinforced Concrete Section	3 (75)
Concrete Masonry	5 (125)
Cast-in-Place Concrete	5 (150)
Brick Masonry	8 (200)

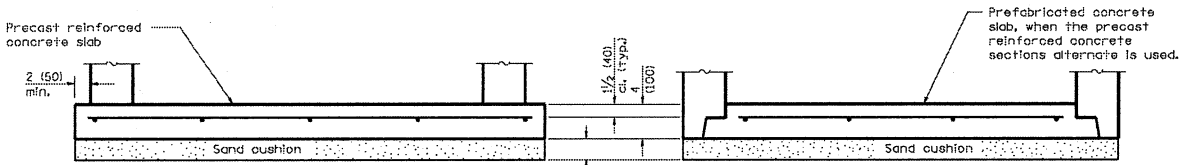

ALTERNATE BOTTOM SLAB

GENERAL NOTES

Bottom slabs shall be reinforced with a minimum of 0.27 sq. in./ft. (570 sq. mm/m) in both directions with a maximum spacing of 9 (230).
 Bottom slabs may be connected to the riser as determined by the fabricator; however, only a single row of reinforcement around the perimeter may be utilized.
 All dimensions are in inches (millimeters) unless otherwise shown.

Illinois Department of Transportation
 PASSED: [Signature] January 1, 2011
 ENGINEER OF POLICY AND PROCEDURES
 APPROVED: [Signature] January 1, 2011
 ENGINEER OF DESIGN AND ENVIRONMENT

DATE	REVISIONS
1-1-11	Detailed reinf. in slabs. Added max. limit to height.
	Added general notes.
1-1-09	Switched units to English (metric).

CATCH BASIN TYPE C

STANDARD 602011-02

REV. 2/27/13

12/10/01

NO. LS-68

REV. 2

VILLAGE OF LEMONT
CATCH BASIN TYPE C

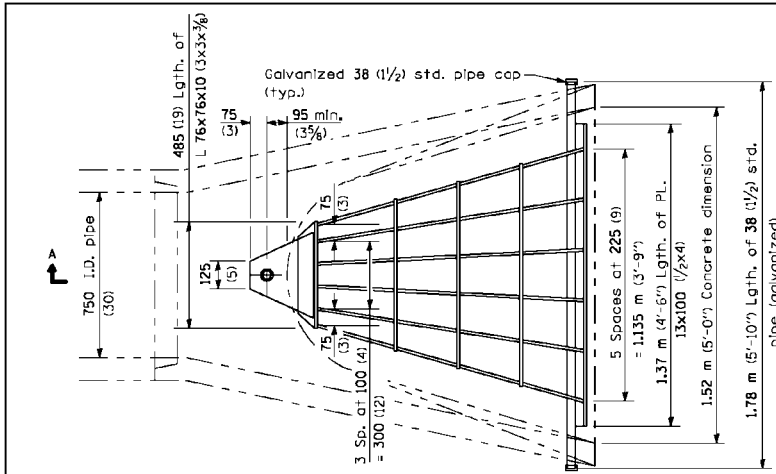

PLAN

Quantity of steel = 95 kg (210 lbs.)

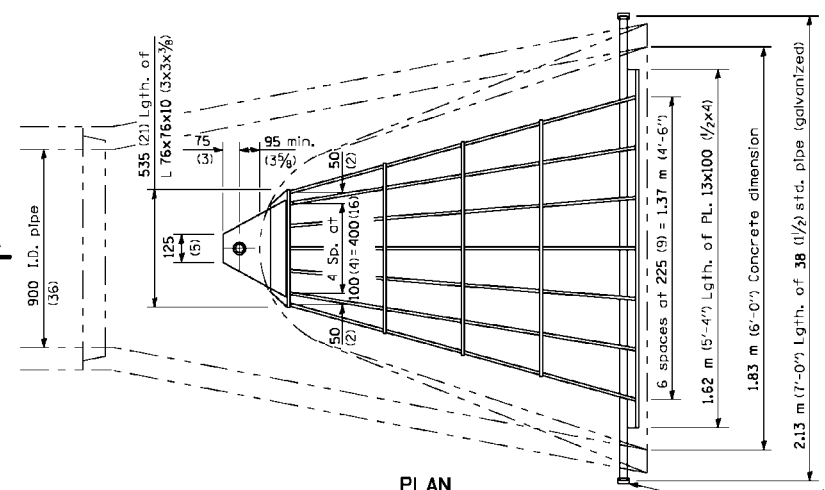

PLAN

Quantity of steel = 127 kg (280 lbs.)

Galvanized 38 (1 1/2) std. pipe cap (typ.)

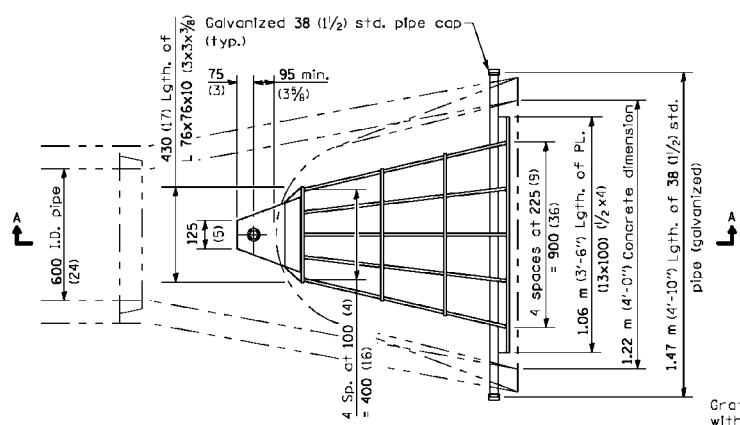

PLAN

Quantity of steel = 68 kg (150 lbs.)

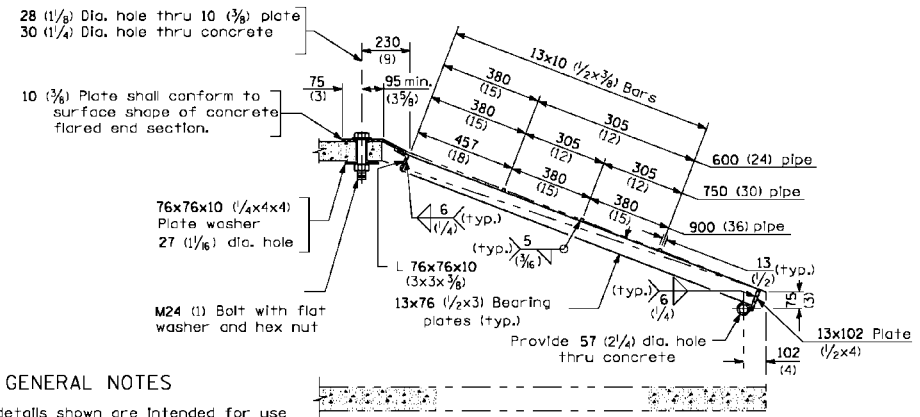

SECTION A-A

All dimensions are in millimeters (inches) unless otherwise shown.

GENERAL NOTES

Grating details shown are intended for use with particular sizes of precast reinforced concrete flared end sections as shown on standards 542301 and 542306.

Approximate quantity of steel shown includes total quantity of grating, bolts, nuts, washers and steel pipe.

Holes in the precast concrete flared end sections shall be cored to the diameters noted. If core-out on the other end of the hole occurs, the hole shall be filled with grout to correct the diameter of the hole.

DATE	REVISIONS
1-1-97	Renum. Standard 2364-3 and Standard 2379-2.
6-15-94	Moved C.N. to Specs. Added Metric.

GRATING FOR CONCRETE FLARED END SECTION (FOR 600 mm (24") THRU 1350 mm (54") PIPE) (Sheet 1 of 2)
STANDARD 542311

Illinois Department of Transportation

PASSED: JUDITH L. 1997

ENGINEER OF POLICY AND PROCEDURES

APPROVED: JUDITH L. 1997

ENGINEER OF DESIGN AND ENVIRONMENT

REV. 4/08/14
REV. 2/27/13

VILLAGE OF LEMONT
GRATING FOR CONCRETE FLARED END SECTION
 12/10/01 NO. LS-69 REV. 3

NOTES:

1. TRENCH WIDTH – MINIMUM TO COMPLY WITH OSHA SAFETY STANDARDS.
2. REINFORCING OF RESTORED PAVEMENT MUST MATCH EXISTING.
3. RESTORATION TO ORIGINAL SURFACE REQUIRED. NO CONCRETE PATCHES ON ASPHALT ROADS.
4. STREETS MUST REMAIN OPEN TO TRAFFIC. WORK ON ONLY ONE HALF OF STREET ALLOWED AT A TIME.
5. CONTRACTORS SHALL ERECT AND MAINTAIN SUFFICIENT AND SUITABLE SIGNS AND BARRICADES DURING AND AFTER CONSTRUCTION.
6. STREETS SHALL BE RESTORED TO THEIR ORIGINAL CONDITION WITHIN 72 HOURS FROM THE TIME THE WORK COMMENCED. STREET OPENINGS SHALL BE BACKFILLED WITH APPROVED GRANULAR MATERIAL AND A TEMPORARY PAVEMENT SURFACE OF COMPACTED, COLD ASPHALT MATERIAL SHALL BE INSTALLED WITHIN 24 HOURS FROM THE TIME THE WORK COMMENCED.
7. A MINIMUM OF 24 HOURS NOTICE MUST BE GIVEN TO THE VILLAGE BEFORE BACKFILLING AND RESTORATION WORK ARE COMMENCED.
8. RESTORED PAVEMENT TO MEET EXISTING PAVEMENT OR THE FOLLOWING MINIMUMS:
 –FOR PCC PAVEMENT USE MINIMUM OF 8" CLASS SI CONCRETE.
 –FOR HOT MIX ASPHALT PAVEMENT USE MINIMUM OF 7" PCC CONCRETE BASE COURSE AND 2" HOT MIX ASPHALT CONCRETE SURFACE COURSE MIXTURE C, N50.

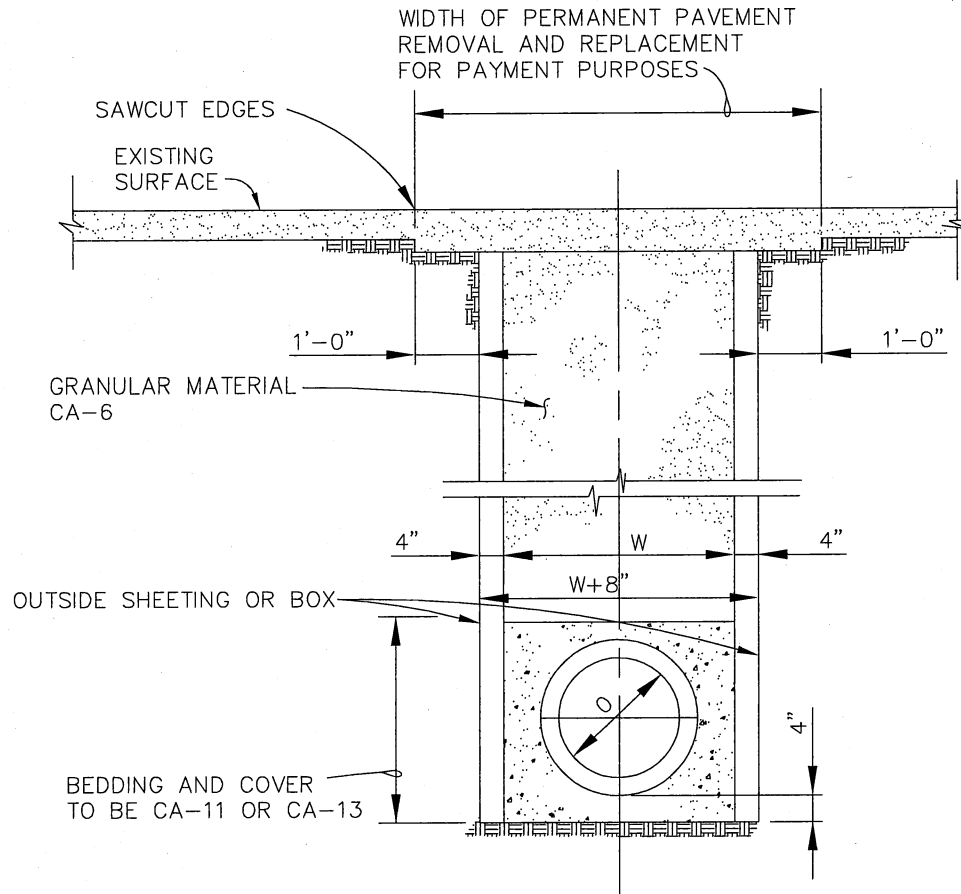

MAXIMUM TRENCH WIDTH W+8"	3'-2"	3'-2"	3'-2"	3'-4"	3'-6"	3'-10"	4'-4"	4'-8"
INSIDE DIAMETER OF CONDUIT IN INCHES "D"	6	8	10	12	15	18	21	24

REV. 6/23/08

12/10/01

NO. LS-70

REV. 1

VILLAGE OF LEMONT
 UTILITY STREET CUTS

REV. 4/08/14
REV. 6/23/08

10/07

NO. LS-71d

REV. 2

TYPE "C" GRATE

VILLAGE OF LEMONT

PAGE
1
OF
5

CAD DWG. REF: 32810002.DWG- 2

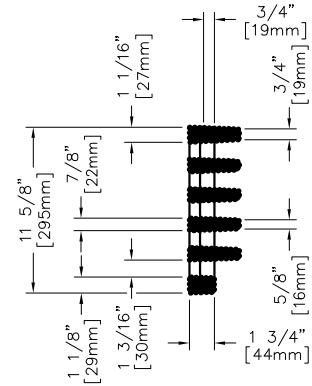
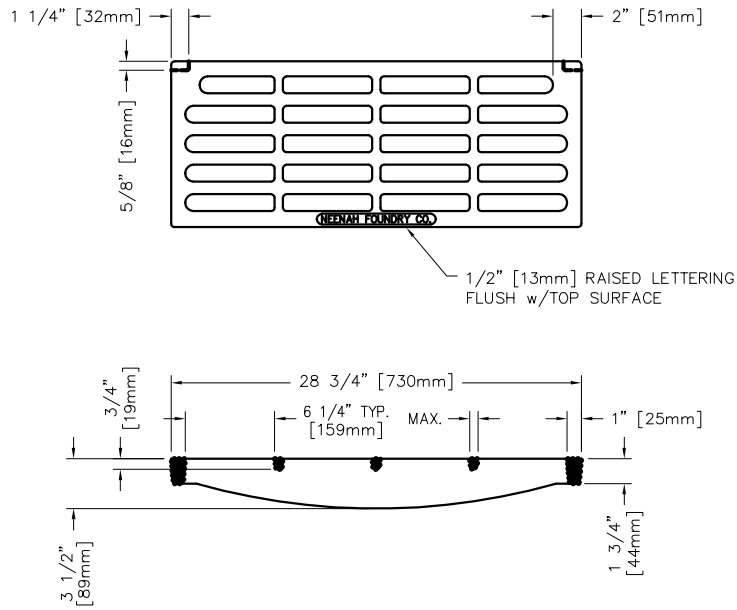

NOTE: ALL DIMENSIONS ARE SHOWN IN ENGLISH AND [METRIC].
MATERIAL: CAST GRAY IRON ASTM A-48, CLASS 35B
FINISH: NOT PAINTED
WEIGHT: 107#

DATE	REVISION	LMA INT
10-13-2000	ADDED LETTERING PER S.A.	

DR. E. REMME	SCALE 1/8"=1"	TITLE: R-3281-A TYPE "C" GRATE
CH.		
APP.	DIM CHK.	
DATE 07-11-95		NEENAH FOUNDRY COMPANY NEENAH WISCONSIN 54956
		NEF NF- 32810002 B

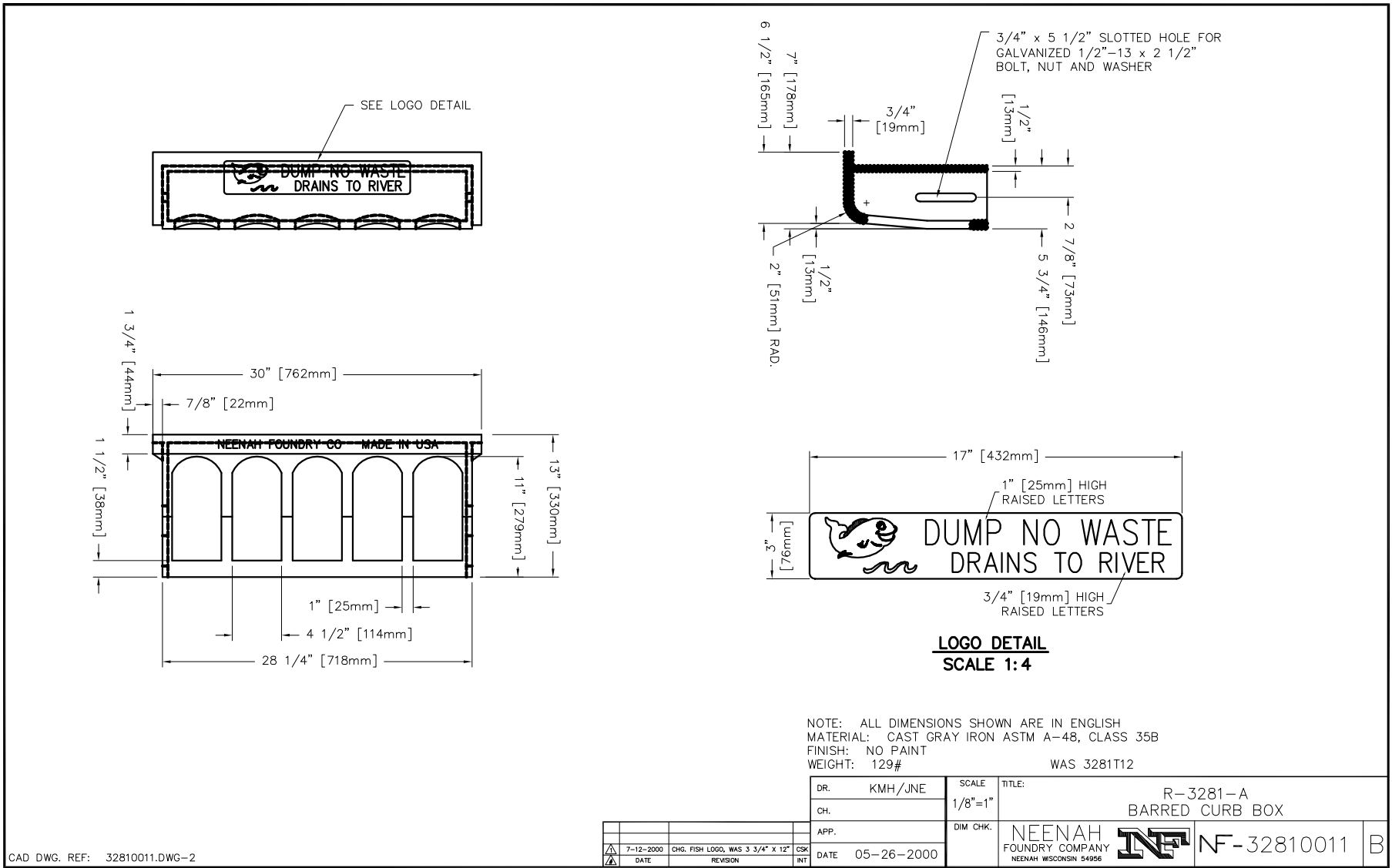

CAD DWG. REF: 32810011.DWG-2

DR.	KMH/JNE	SCALE	1/8"=1"	TITLE:	R-3281-A BARRED CURB BOX
CH.		DIM CHK.		NEENAH FOUNDRY COMPANY NEENAH WISCONSIN 54956	 NF-32810011
APP.		DATE	05-26-2000		B
DATE	7-12-2000	REVISION	CHG. FISH LOGO, WAS 3 3/4" X 12"		

REV. 4/08/14
REV. 6/23/08

VILLAGE OF LEMONT
BARRED CURB BOX
10/07 NO. LS-71b REV. 2

PAGE 2 OF 5

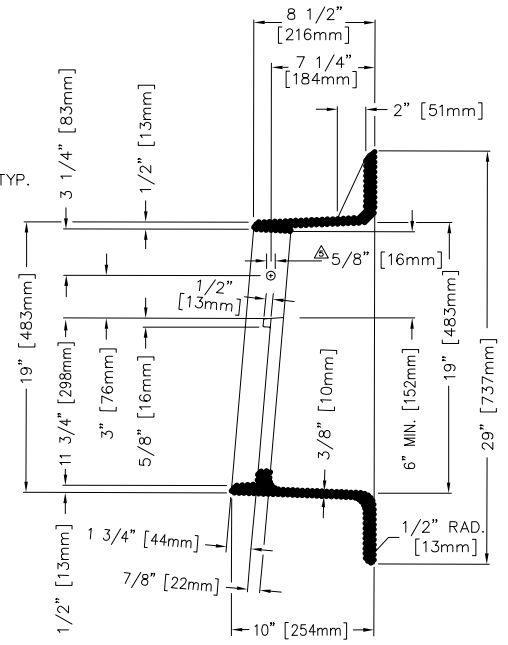
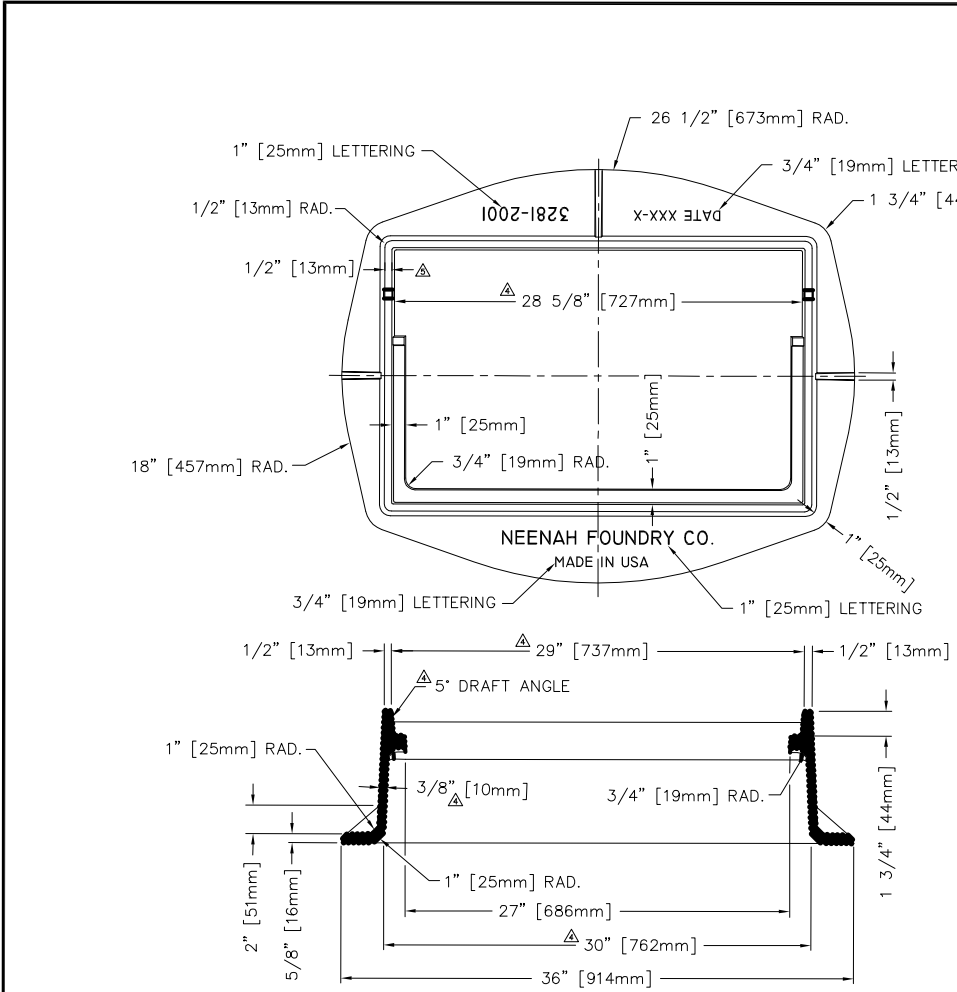

NOTE: ALL DIMENSIONS ARE SHOWN IN ENGLISH AND [METRIC].
 MATERIAL: CAST GRAY IRON ASTM A-48, CLASS 35B
 FINISH: NO PAINT
 WEIGHT: 157#

CAD DWG. REF: 32812001.DWG-6

		DR. E. REMME	SCALE 1/8"=1"	TITLE: R-3281-A/R-3281-B CATCH BASIN FRAME
09-14-2006	WAS GREENSAND SLOT & WAS 5/8" THICK	SMA		
08-18-2004	CHECKED WITH ALL PLATES, CORRECTED DIMS	ELR		
07-09-2004	CHANGED DIMS PER MANUFACTURING	ELR		
10-23-2003	REVISED RADI ON INSIDE AND OUTSIDE OF FLANGE	ELR		
12-10-98	REVISE GUSSETS, FLANGE	CSK		
	DATE	REVISION		
		DATE 11-21-96	DIM CHK.	NEENAH FOUNDRY COMPANY NEENAH WISCONSIN 54956
				NF-32812001 B

REV. 4/08/14
 REV. 6/23/08

VILLAGE OF LEMONT
 CATCH BASIN FRAME
 10/07 NO. LS-71c REV. 2

PAGE 3 OF 5

REV. 4/08/14
REV. 6/23/08

VILLAGE OF LEMONT
NEENAH R-2015 GRATE
NO. LS-71d
REV. 2

PAGE
4
OF
5

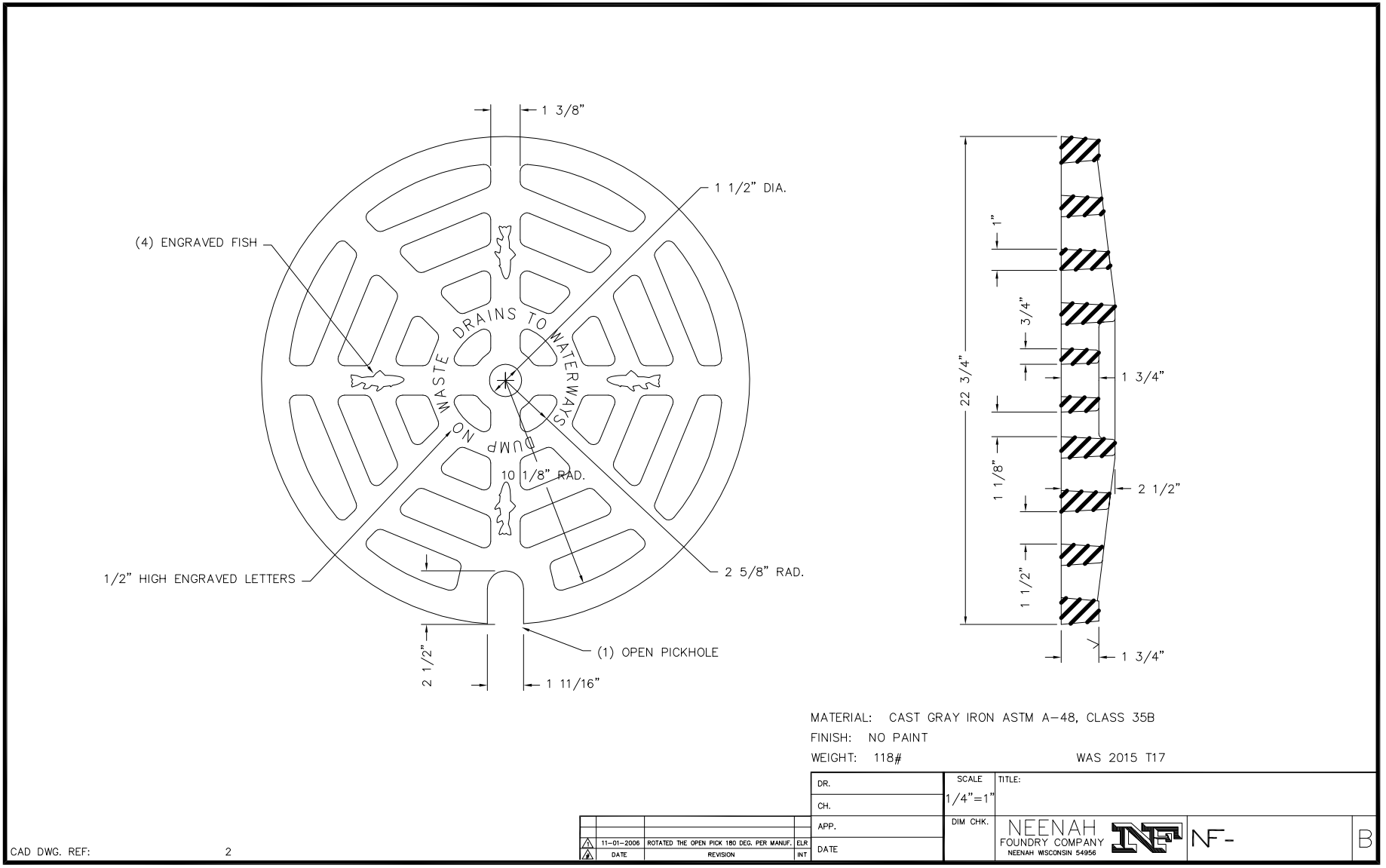

REV. 4/08/14
 REV. 6/23/08

10/07

NO. LS-71e

REV. 1

BEEHIVE GRATE

VILLAGE OF LEMONT

PAGE
 5
 OF
 5

CAD DWG. REF: 1

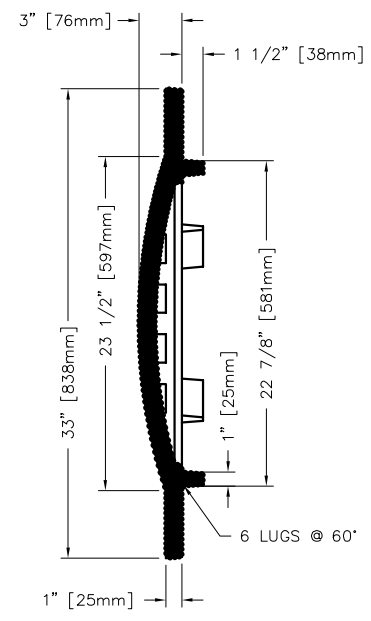
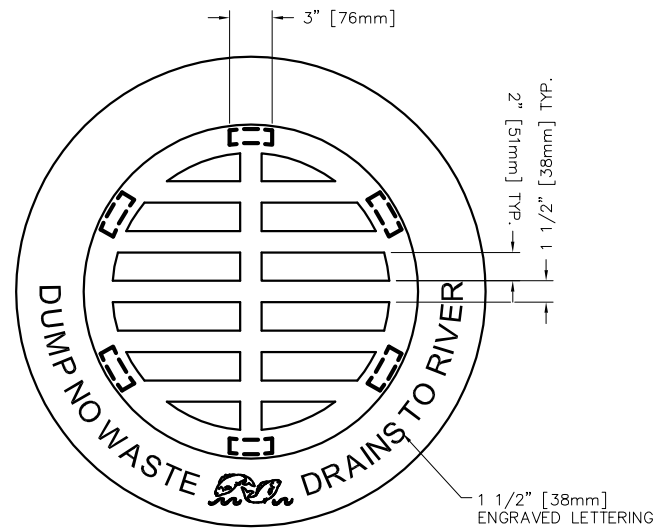

NOTE: ALL DIMENSIONS SHOWN ARE IN ENGLISH AND [METRIC]
 MATERIAL: CAST GRAY IRON ASTM A-48, CLASS 35B
 FINISH: NO PAINT
 WEIGHT: 181#

DR.	SCALE	TITLE:		
CH.	1/8" = 1"			
APP.	DIM. CHK.	NEENAH FOUNDRY COMPANY NEENAH WISCONSIN 54956		NF-
DATE				B

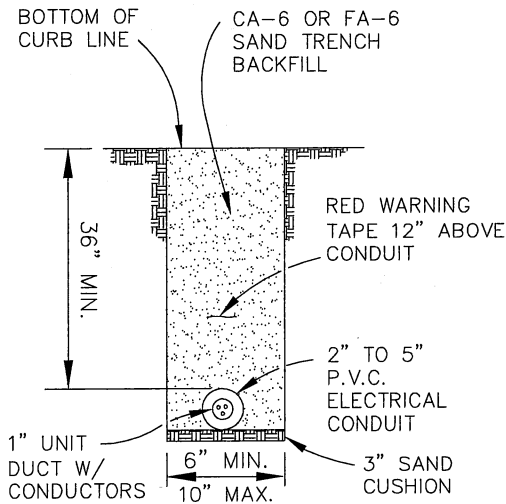

PAVEMENT CROSSING

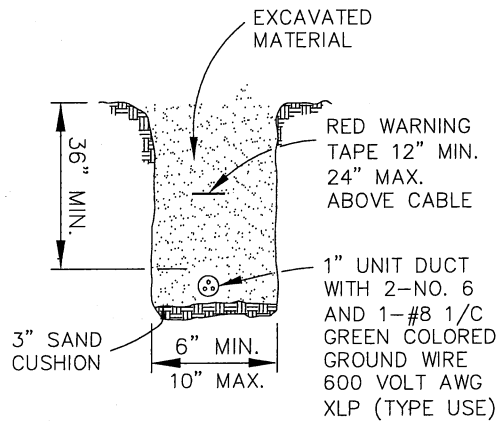

TRENCH BURIAL

CABLE BURIAL DETAIL

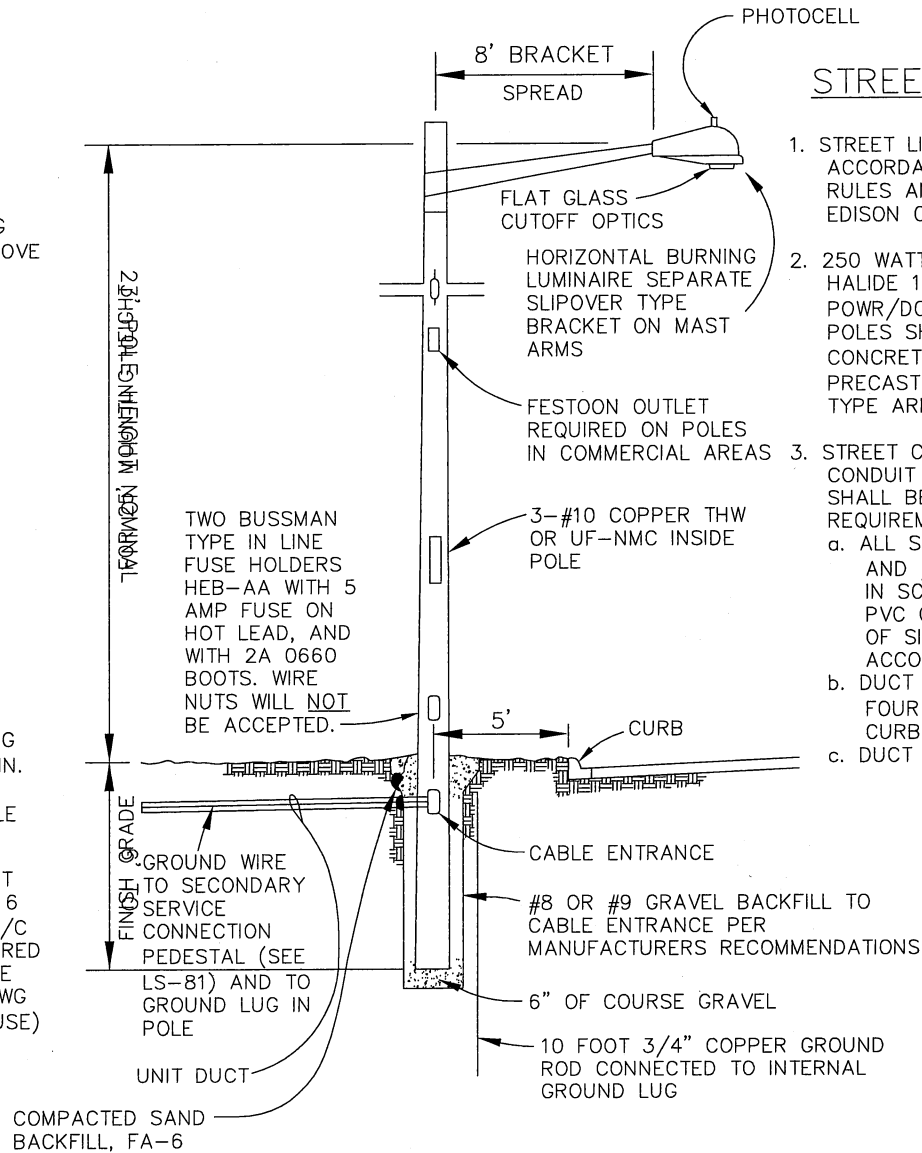

STREET LIGHTING

1. STREET LIGHTING SHALL BE INSTALLED IN ACCORDANCE WITH THE CURRENT SERVICE RULES AND POLICIES OF COMMONWEALTH EDISON CO.
2. 250 WATT LUMINARIES SHALL BE METAL HALIDE 120 VOLT, GENERAL ELECTRIC M250A2 POWR/DOOR W/ CUTOFF OPTICS OR EQUAL. POLES SHALL BE AMERON CENTRECON CONCRETE POLE #ME07-114-MOAD8 6'-0" PRECAST BUTT AND A 8'-0" ALUMINUM DAVIT TYPE ARM FOR A 2 INCH SLIPFITTER.
3. STREET CROSSINGS OF ELECTRICAL CONDUIT OR THE STREET LIGHTING SYSTEM SHALL BE SUBJECT TO THE FOLLOWING REQUIREMENTS:
 - a. ALL STREET CROSSINGS OF CONDUCTOR AND / OR CABLE WILL BE INSTALLED IN SCHEDULE 40, HEAVY WALL RIGID PVC CONDUIT OR GALVANIZED STEEL OF SIZE REQUIRED BY C.E.C. TO ACCOMMODATE CONDUCTION UML 27
 - b. DUCT SHALL EXTEND A MINIMUM OF FOUR (4) FEET BEYOND THE BACK OF CURB ON EACH SIDE OF STREET.
 - c. DUCT SHALL BE CAPPED AT BOTH ENDS.

REV. 2/07/10
REV. 6/23/08

VILLAGE OF LEMONT
STREET LIGHTING
NO. LS-80
REV. 3

SECONDARY SERVICE CONNECTION PEDESTALS

B-3

FEATURES:

- 14 gauge 235 mill galvanized steel with 12 gauge hasp
- Powder coated paint
- Stainless rivets
- Safety ribs provide strength and more secure unit
- Rounded front
- Recessed pentalock feature available upon request
- A quality product for 40 years

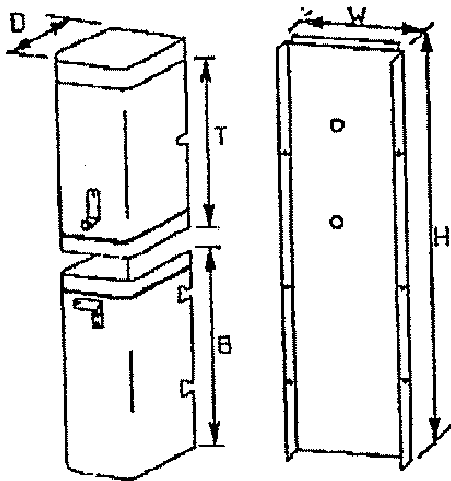
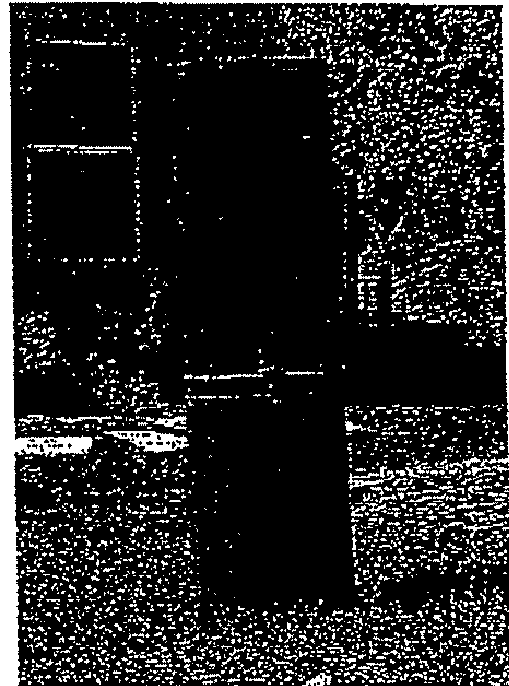

CAT#	D	W	T	B	H	COMMENTS
202-3 DOME	7-1/2	7-1/2	20-5/8	20-5/8	38	Standard Unit
202-3C	7-1/2	7-1/2	20-5/8	20-5/8	38	Swinging Knockout
202-3CPHB	7-1/2	7-1/2	21	26	46	Pentalock + Swinging Knockout
204-38	10-1/2	10-1/2	21-1/8	18	38	Standard 10 1/2 x 10 1/2
204-38C	10-1/2	10-1/2	21-1/8	18	38	Swinging Knockout
204-38CPH	10-1/2	10-1/2	21-1/8	18	38	Pentalock + Swinging Knockout
203-5PH	10-1/2	10-1/2	15-3/4	13-1/4	28	
208-44R	10-1/2	10-1/2	21-1/8	24	44	

VILLAGE OF LEMONT
 CONNECTION PEDESTALS
 1 OF 2

REV. 4/08/14
 REV. 6/23/08

10/07

NO. LS-81a

REV. 2

PEDESTAL MOUNTING POSTS page B-5

EMCO joint pedestal mounting posts are available in one basic shape, the "M" Channel. Common lengths are 72", 78" and 84". Stocked posts are hot dip galvanized. Painted posts are available on special order. Note: special non-joint hot dipped galvanized telephone pedestal mounting posts, Cat# 42AMSK are also available (see drawing below).

EMCO Joint Pedestal Mounting Posts

CAT#	LNTH	DESCRIPTION	LBS
13MAC72	72"	M Shape, 13 GA Hot Dip Galv, T Slotted Sides (p B-7)	10.3
13M542HW	42"	M Shape, 13 GA Hot Dip Galv, T Slotted Sides (p B-8)	6
13MHK34	34"	M Shape, 13 GA Hot Dip Galv	5
13MHK72	72"	M Shape, 13 GA Hot Dip Galv	10.3
13MHK84	84"	M Shape, 13 GA Hot Dip Galv	12
1472SF	72"	M Shape, 13 GA Paint Seafoam Green	10.3
1478SF	78"	M Shape, 13 GA Paint Seafoam Green	11.2
1484DRG	84"	M Shape, 13 GA Paint Dark Green	12

Note: Mounting hardware configuration currently under revision.



TOP VIEW OF "M" POST SCALED 2X

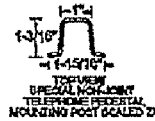

TOP VIEW SPECIAL NON-JOINT TELEPHONE PEDESTAL MOUNTING POST SCALED 2X

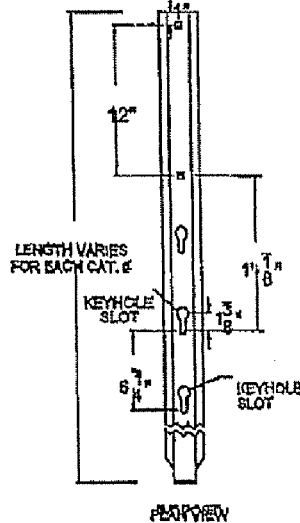

SIDE VIEW

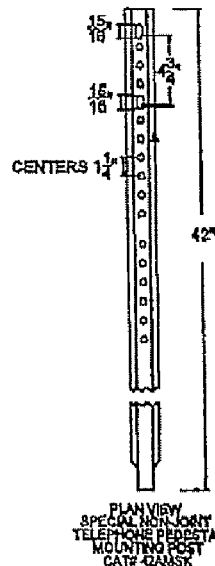

SIDE VIEW SPECIAL NON-JOINT TELEPHONE PEDESTAL MOUNTING POST CAT# 42AMSK

ELECTRICAL MATERIALS COMPANY

145 ELIZABETH LANE, GENOA CITY, WI 53128.
(262) 279-3812 FAX (262) 279-6824

VILLAGE OF LEMONT
CONNECTION PEDESTALS
2 OF 2

REV. 4/08/14
REV. 6/23/08

10/07 NO. LS-81b REV. 2

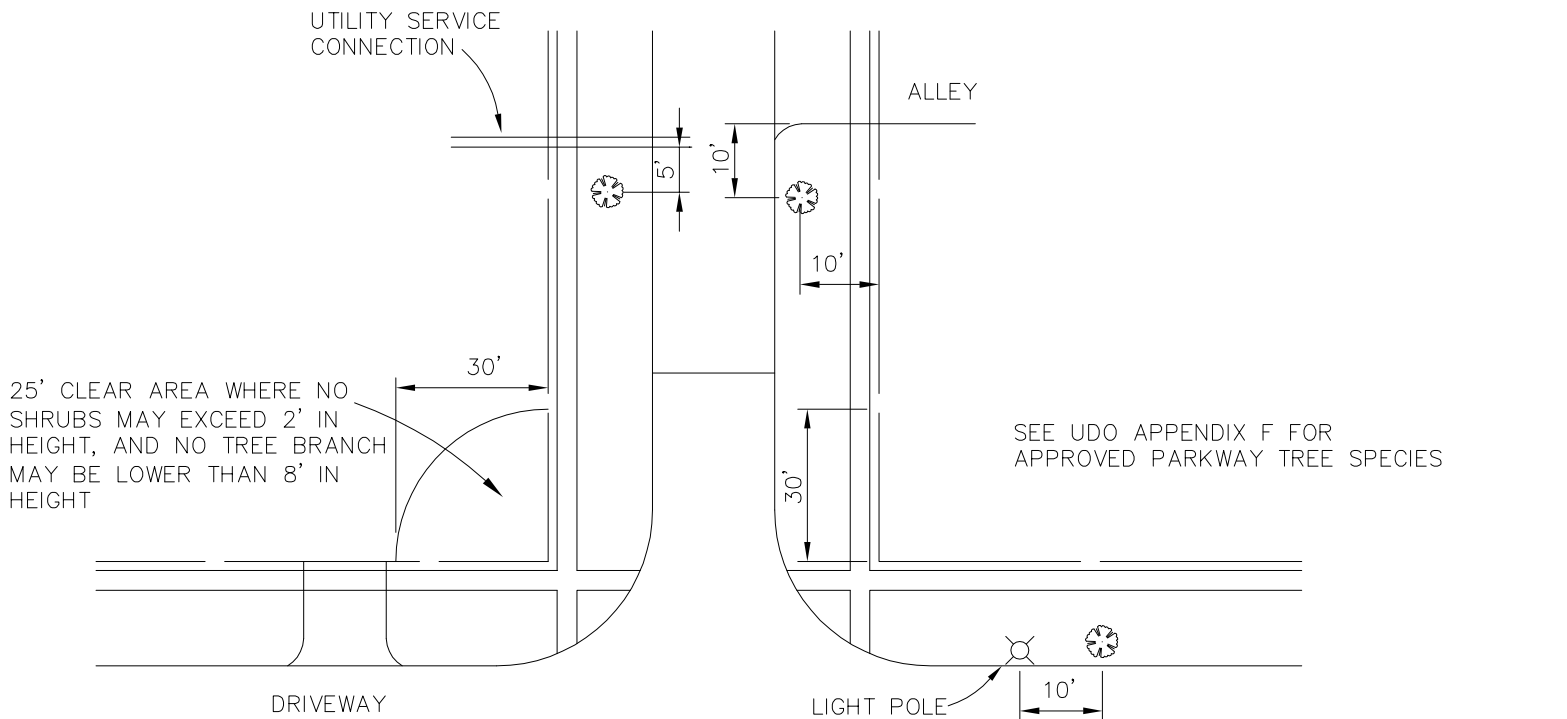

PERMITTED TREE LOCATIONS

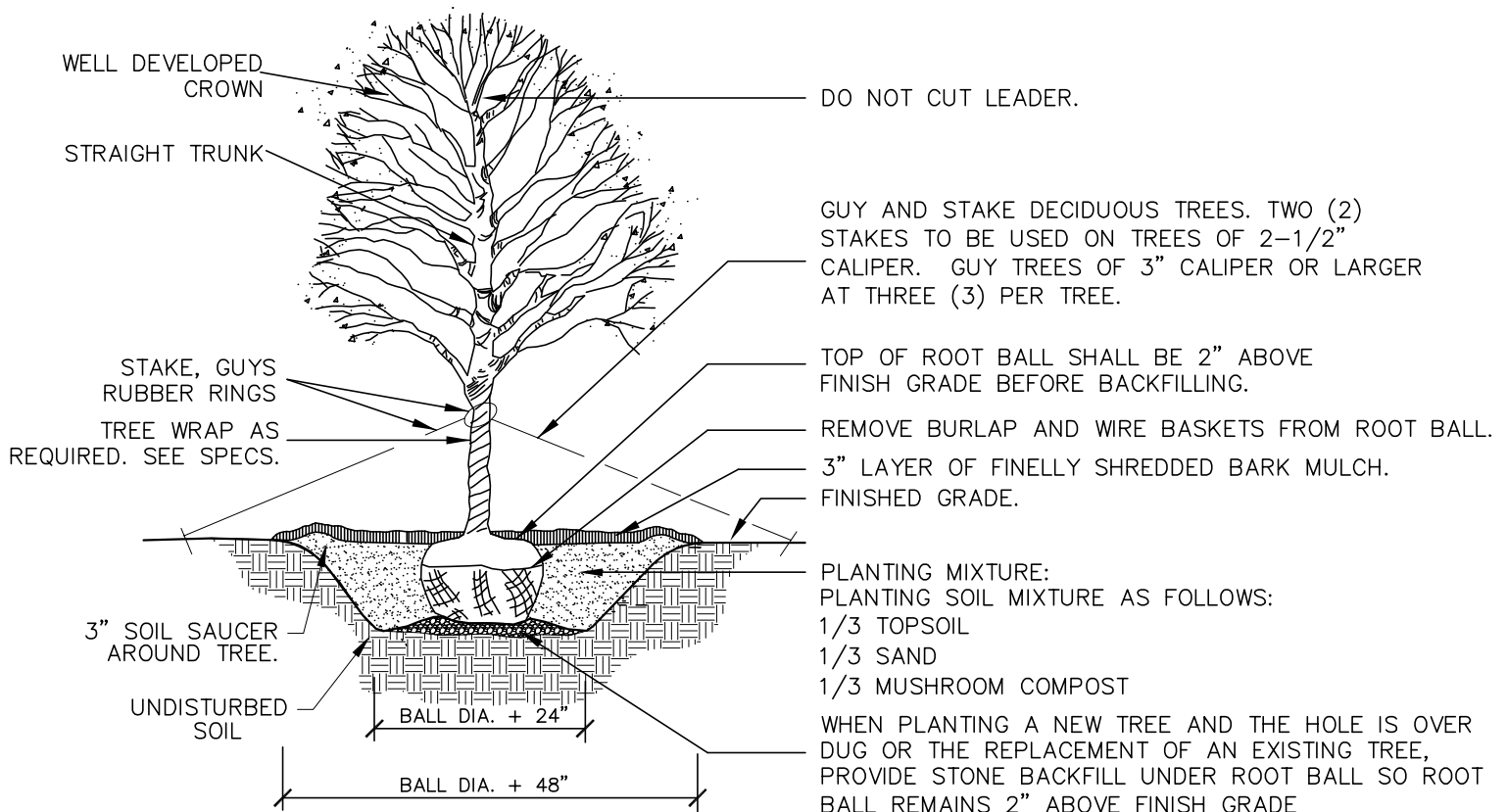

TREE PLANTING DETAIL

NOTES:

1. TREES SHALL HAVE A MINIMUM TRUNK DIAMETER OF 2 1/2 INCHES. TREES UP TO AND INCLUDING 4 INCHES ARE MEASURED 6 INCHES ABOVE GROUND. TREES LARGER THAN 4 INCHES ARE MEASURED 12 INCHES ABOVE GROUND.
2. A MINIMUM OF 2 (TWO) TREES PER LOT; AT LEAST 1 (ONE) TREE EVERY 40 FEET SHALL BE REQUIRED IN ALL NEW SUBDIVISIONS.
3. PRUNING, IF NECESSARY, MUST BE DONE AFTER PLANTING AND ONLY IF TREES HAVE BROKEN BRANCHES.
4. PLANTINGS SHALL BE PER THE URBAN FORESTRY MANAGEMENT PLAN OF THE VILLAGE OF LEMONT.
5. TREE SPECIES PLACEMENT SHALL BE A STAGGERED PATTERN, SUCH THAT NO TREES OF THE SAME TYPE ARE NEXT TO EACH OTHER
6. TREES SHALL BE PLANTED AT LEAST 15 FEET AWAY FROM ALL TRAFFIC SIGNS.
7. SEE UDO APPENDIX F FOR APPROVED PARKWAY TREE SPECIES.

REV. 4/08/14
 REV. 10/10/13
 REV. 4/13/10
 REV. 11/09/09
 REV. 6/23/08

VILLAGE OF LEMONT		
TREE PLANTING		
12/10/01	NO. LS-90	REV. 5

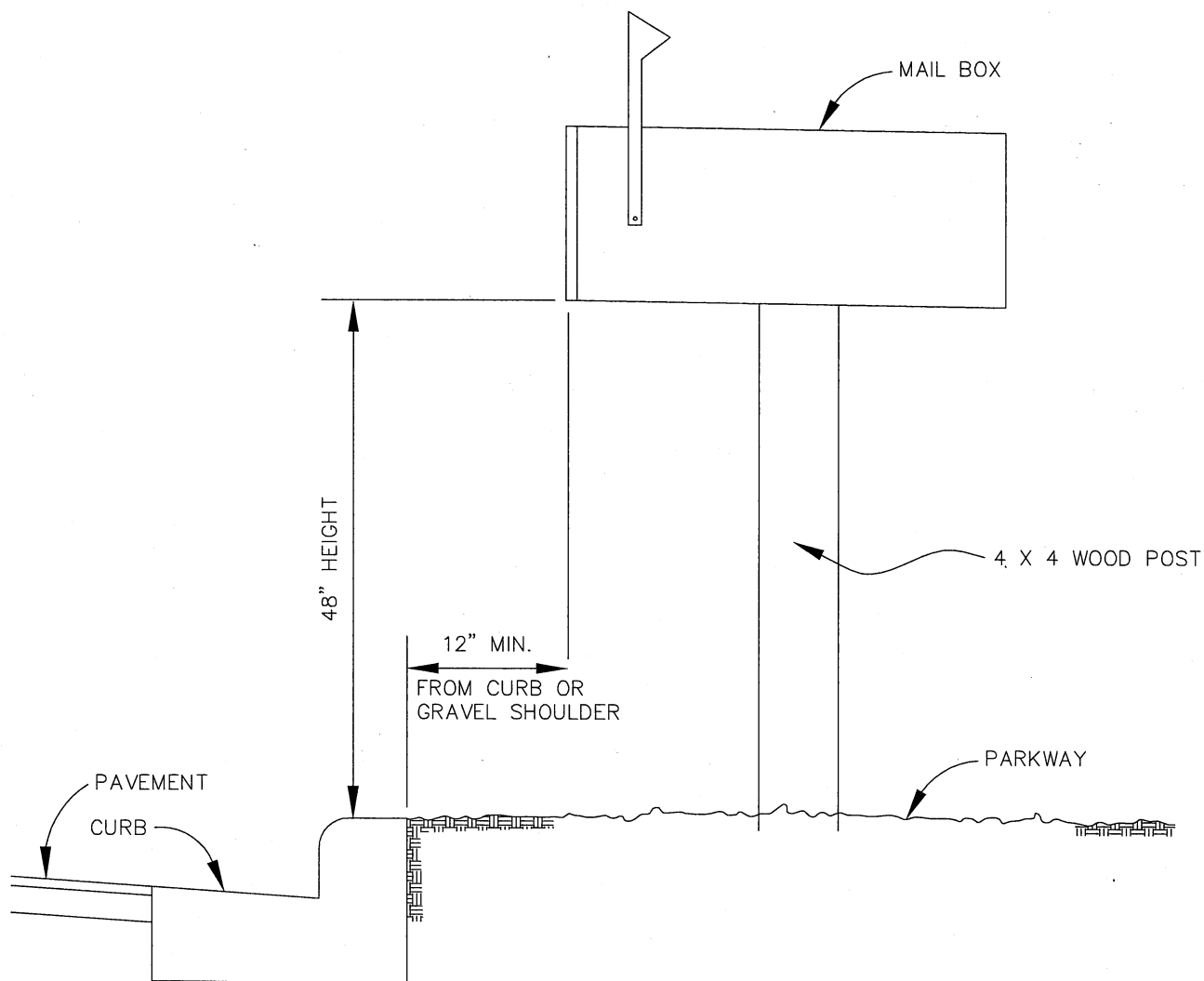

- THE MAIL BOX MUST BE PLACED SO THAT IT IS ACCESSIBLE FOR THE DELIVERY OF MAIL FROM THE POSTAL CARRIERS VEHICLE.
- SAFETY NOTE: PRIOR TO ANY DIGGING WITHIN THE PARKWAY, PLEASE HAVE ALL UTILITIES LOCATED AND MARKED (WATER, SEWER, GAS, ELECTRIC AND TELEPHONE).

CALL
JULIE
1-800-892-0123

VILLAGE OF LEMONT
AND DEPARTMENT OF PUBLIC WORKS
1-630-257-2532

PRIOR TO INSTALLATION

VILLAGE OF LEMONT

MAIL BOX

REV. 6/23/08

12/10/01

NO. LS-91

REV. 1

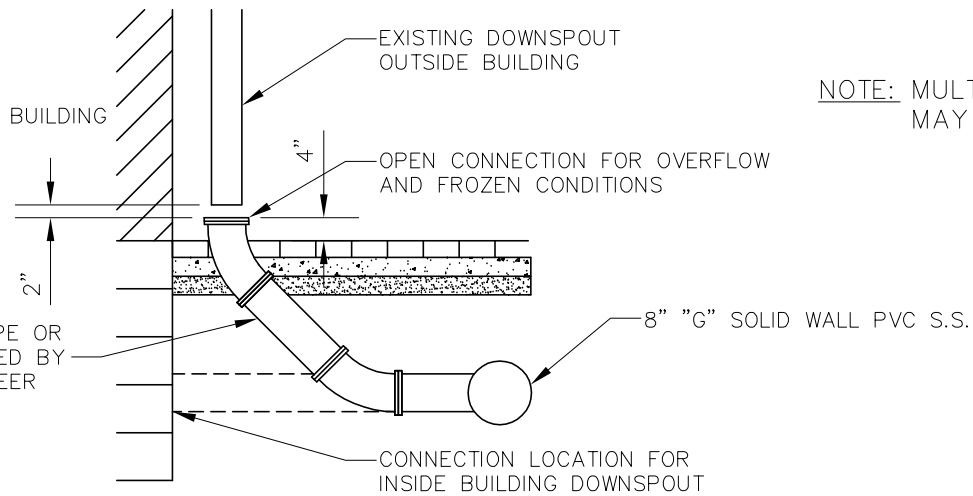

NOTE: MULTIPLE DOWNSPOUT OUTLETS MAY BE REQUIRED PER BUILDING.

EXACT LOCATION TO BE DETERMINED IN THE FIELD.

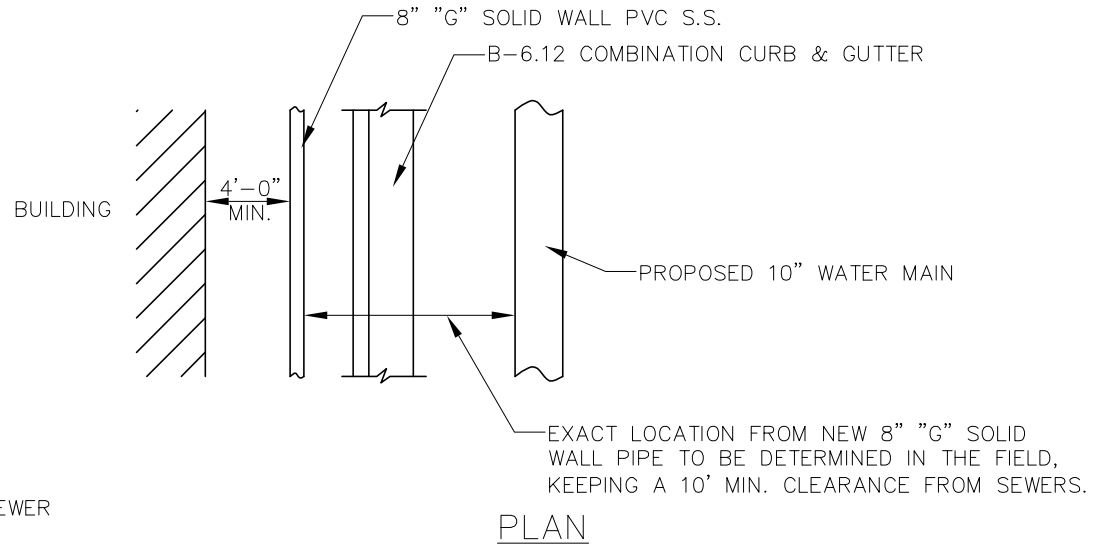

PLAN

NOTE: WHEN 10' MINIMUM CANNOT BE MAINTAINED, 8" PVC MUST BE CONSTRUCTED OF WATER MAIN QUALITY PIPE.

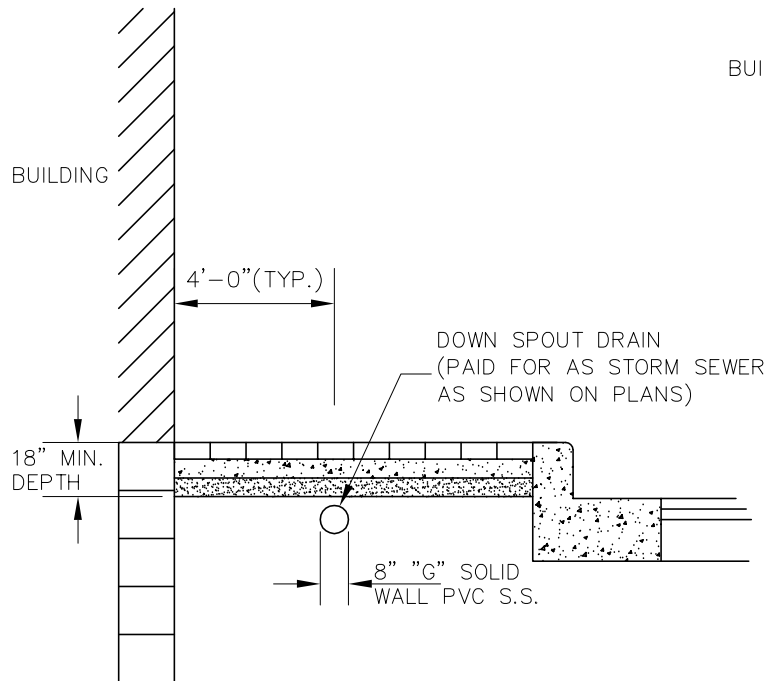

* REFER TO PLANS FOR STORM SEWER INVERTS AND DRAINAGE

SECTION

REV. 4/08/14

8/14/02

NO. LS-92

REV. 1

VILLAGE OF LEMONT
DOWN SPOUT GRAVITY
SEWER CONNECTION

NOTE: WATERPROOF BACKFACE, SEE ARTICLE 503.18 OF THE STANDARD SPECIFICATIONS FOR MATERIALS AND METHOD OF APPLICATION.

CONTRACTOR TO PROVIDE PROTECTION FROM ELEMENTS AND A METHOD OF SECURING OPENING INTO BUILDING UPON REMOVAL OF EXISTING SIDEWALK OVER VAULT (INCIDENTAL TO CONCRETE SIDEWALK REMOVAL, SPECIAL)

HEIGHT(H)	WIDTH(W)
5.5'	3.5'
6.0'	4.0'
6.5'	4.0'
7.0'	4.5'
7.5'	4.5'
8.0'	5.0'
8.5'	5.0'
9.0'	5.5'

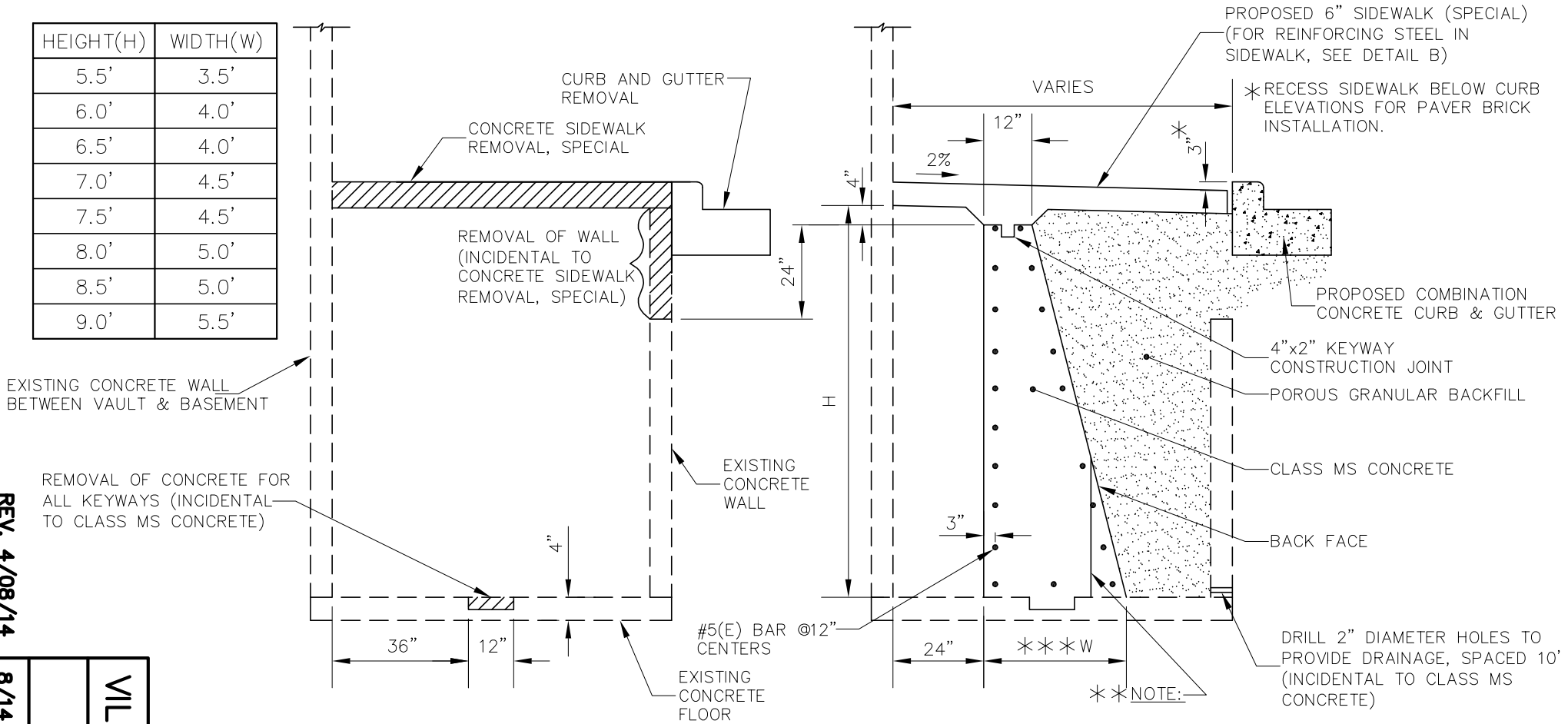

* NOTE: CONTRACTOR TO CONFIRM DEPTH OF SAND SET PAVER SYSTEM PRIOR TO SETTING FINAL GRADE OF SIDEWALK (SPECIAL). MINIMUM 3/4" SAND COURSE MAY VARY IN THICKNESS AND WILL BE CONSIDERED INCIDENTAL TO THE PAVERS.

** NOTE: COORDINATE RETAINING WALL CONSTRUCTION WITH LIGHT POLE FOUNDATIONS. PROVIDE RECESS AS NECESSARY FOR LIGHT POLE FOUNDATION CONSTRUCTION.

*** NOTE: (W) WIDTH VARIES WITH (H) HEIGHT, SEE TABLE AT LEFT.

REV. 4/08/14

8/14/02

NO. LS-93a

REV. 1

VILLAGE OF LEMONT
SIDEWALK VAULTS
1 OF 3

NOTE: WATERPROOF BACKFACE, SEE ARTICLE 503.18 OF THE STANDARD SPECIFICATIONS FOR MATERIALS AND METHOD OF APPLICATION.

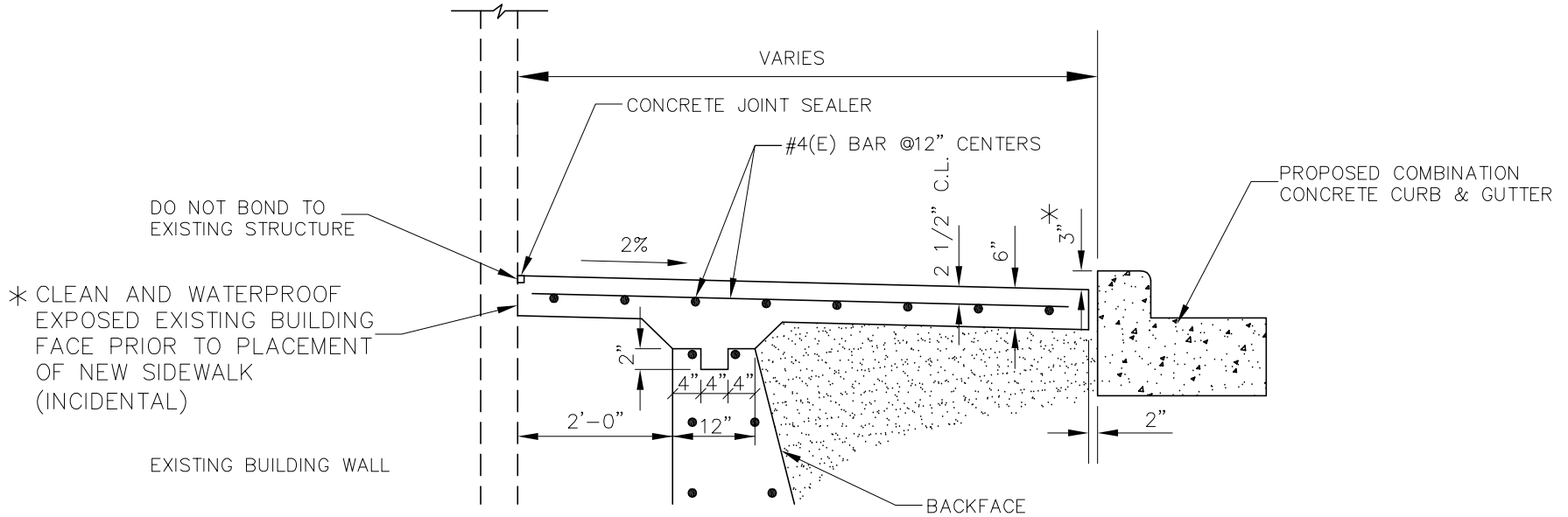

DETAIL B

* NOTE: CONTRACTOR TO CONFIRM DEPTH OF SAND SET PAVER SYSTEM PRIOR TO SETTING FINAL GRADE OF SIDEWALK (SPECIAL). MINIMUM 3/4" SAND COURSE MAY VARY IN THICKNESS AND WILL BE CONSIDERED INCIDENTAL TO THE PAVERS.

REV. 4/08/14

8/14/02

NO. LS-93b

REV. 1

VILLAGE OF LEMONT

SIDEWALK VAULTS

2 OF 3

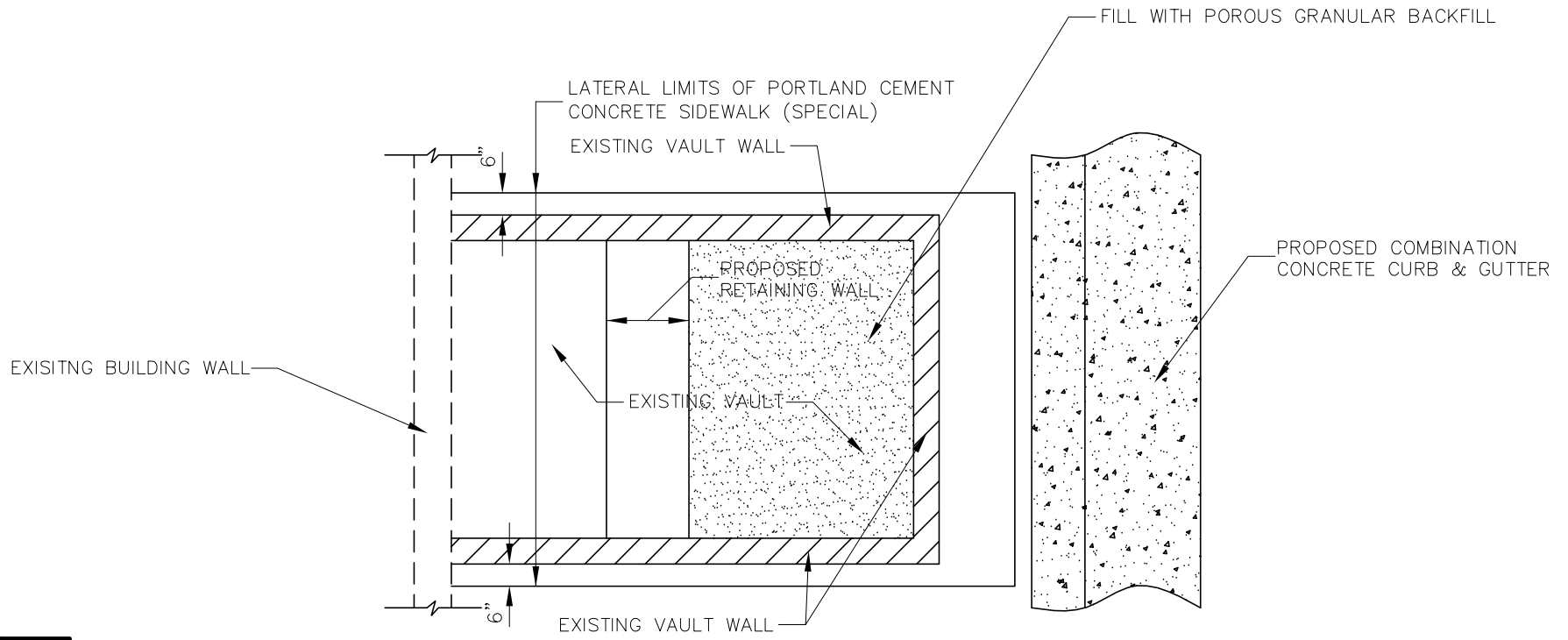

PLAN VIEW

REV. 4/08/14

VILLAGE OF LEMONT		
SIDEWALK VAULTS		
3 OF 3		
8/14/02	NO. LS-93c	REV. 1

Village Board Agenda Memorandum

To: Mayor & Village Board

From: George Schafer, Village Administrator
Chris Smith, Finance Director

Subject: An Ordinance Amending Title 1 of the Lemont, Illinois
Municipal Code Relating to General Penalty and Late Fees

Date: May 7, 2014

BACKGROUND/HISTORY

Recently staff has been working with the Board and legal to clean up delinquencies as well as any ordinances pertaining to fees and/or outstanding account balances. The attached ordinance is another step to ensure that the Village receives all fees and/or charges for services previously billed. Additionally, language has been added to allow for late fees.

RECOMMENDATION

Pass the attached Ordinance Amending Title 1 of the Lemont, Illinois Municipal Code Relating to General Penalty and Late Fees.

**VILLAGE OF LEMONT
ORDINANCE NO. _____**

**An Ordinance Amending Title 1 of the Lemont, Illinois
Municipal Code Relating to General Penalty and Late Fees**

**ADOPTED BY THE
PRESIDENT AND THE BOARD OF TRUSTEES
OF THE VILLAGE OF LEMONT
THIS ___ DAY OF _____, 2014**

**Published in pamphlet form by
Authority of the President and
Board of Trustees of the Village of
Lemont, Counties of Cook, Will and
DuPage, Illinois, this ___ day of _____, 2014.**

ORDINANCE NO. _____

**An Ordinance Amending Title 1 of the Lemont, Illinois
Municipal Code Relating to General Penalty and Late Fees**

WHEREAS, the Village of Lemont (“Village”) is an Illinois Municipal Corporation pursuant to the Illinois Constitution of 1970 and the Statutes of the State of Illinois; and

WHEREAS, the Village President and Board of Trustees desire to amend a certain provision of the Lemont, Illinois Municipal Code (“Village Code”); and

WHEREAS, the Village finds that it is in the best interests of the Village and its residents to amend Section 1.16.010 of the Village Code in the manner set forth below;

NOW, THEREFORE, BE IT ORDAINED BY THE PRESIDENT and BOARD OF TRUSTEES OF THE VILLAGE OF LEMONT, COOK, DUPAGE AND WILL COUNTIES, ILLINOIS, as follows:

SECTION 1: The statements set forth in the preamble to this Ordinance are found to be true and correct and are incorporated into this Ordinance as if set forth in full.

SECTION 2: The Village Code, as amended, is hereby further amended in Title 1, GENERAL PROVISIONS, by amending Section 1.16.010 General Penalty, by adding a new subsection (g) so that the same shall be read as follows:

- (g) That prior to the issuance of any license, certificate and/or permit required pursuant to the laws and ordinances of the Village of Lemont, the Village Clerk, or his/her duly designated agent, shall ascertain that there are no unpaid charges for water service, other municipal services or any other municipal fees, fines, judgments, levies or debts then due and unpaid. No such license, certificate or permit shall be approved or issued until such time as the applicant presents to the appropriate department a certificate of the Village Clerk, or his/her duly designated agent, indicating that all charges, fees, assessments, fines, judgments, levies or debts, owed to the Village have been paid in full.

SECTION 3: The Village Code, as amended, is hereby further amended in Title 1, GENERAL PROVISIONS, by adding a new Chapter 1.18 and new Section 1.18.010 entitled “Late Fees,” so that the same shall be read as follows:

Section 1.18.010

Any fee, fine, charge, cost or other expense not paid within thirty (30) days of the date due shall be assessed a late fee in the amount of \$50.00. The late fee shall be in addition to the original amount owed.

SECTION 4: The provisions of this Ordinance are hereby declared to be severable, and should any provision of this Ordinance be determined to be in conflict with any law, statute or regulation by a court of competent jurisdiction, said provision shall be excluded and deemed inoperative, unenforceable and as though not provided for herein and all other provisions shall remain unaffected, unimpaired, valid and in full force and effect.

SECTION 5: That the Village Clerk of the Village of Lemont be and is directed hereby to publish this Ordinance in pamphlet form, pursuant to the Statutes of the State of Illinois, made and provided.

SECTION 6: This Ordinance shall be in full force and effect from and after its passage, approval, and publication as provided by law.

PASSED AND APPROVED BY THE PRESIDENT AND BOARD OF TRUSTEES OF THE VILLAGE OF LEMONT, COUNTIES OF COOK, WILL, AND DUPAGE, ILLINOIS, on this ____ day of _____, 2014.

PRESIDENT AND VILLAGE BOARD MEMBERS:

	AYES:	NAYS:	ABSENT:	ABSTAIN
Debby Blatzer	_____	_____	_____	_____
Paul Chialdikas	_____	_____	_____	_____
Clifford Miklos	_____	_____	_____	_____
Rick Sniegowski	_____	_____	_____	_____
Ron Stapleton	_____	_____	_____	_____
Jeanette Virgilio	_____	_____	_____	_____

BRIAN K. REAVES, President

ATTEST:

CHARLENE M. SMOLLEN
Village Clerk

**Village Board
Agenda Memorandum**

To: Mayor & Village Board

From: Chief Kevin W. Shaughnessy

Date: May 12, 2014

Re: Resolution Approving License Agreement with
Integrity Security Personnel Conceal Carry, Inc

BACKGROUND/HISTORY

The Police Department was approached by Integrity Security Personnel for use of our outdoor range. It will be used by licensed and insured firearms instructors to conduct concealed carry firearms training. The Village will be paid for the use and upkeep of the range. The Lemont Police range is not used on Saturday and Sunday. Use of the range will be granted based on operational needs, weekend use only and by appointment.

PROS/CONS/ALTERNATIVES (IF APPLICABLE)
RECOMMENDATIONS

Passage of the attached resolution.

ATTACHMENTS

Resolution

SPECIFIC VILLAGE BOARD ACTION REQUIRED

Resolution approval.

Resolution No. _____

**Resolution Approving License Agreement with
Integrity Security Personnel Conceal Carry, Inc.**

WHEREAS, Village of Lemont desires to enter into a License Agreement with Integrity Security Personnel Conceal Carry, Inc., (“**Licensee**”) a copy of which is attached hereto as Exhibit A;

WHEREAS, Village of Lemont is the owner of a certain facility commonly referred to as the Lemont Police Department, located at 14600 127th Street, Lemont, IL 60439 (the “**Property**”);

WHEREAS, Licensee is an Illinois corporation that provides firearm and concealed carry training, education, and instruction to Village residents and the general public;

WHEREAS, Licensee desires to use portions of the Property, specifically including the shooting range, to conduct training, educational, and instructional classes on concealed carry and firearms safety for Village residents and the general public (collectively, the “**Licensed Activities**”); and

WHEREAS, the Village has determined that this Agreement will help promote firearm safety and education; and

WHEREAS, the Village has determined that this Agreement is in the best interest of the public health, safety and welfare of the residents of the Village;

BE IT RESOLVED by the Village President and Board of Trustees of the Village of Lemont as follows:

SECTION ONE: The foregoing findings and recitals, and each of them, are hereby adopted as Section One of this Resolution and are incorporated by reference as if set forth verbatim herein

SECTION TWO: The Mayor and/or Village Administrator are authorized to execute the License Agreement attached hereto as Exhibit A, to make minor changes to the document prior to execution which do not materially alter the Village's obligations, and to take any other steps necessary to carry out this Resolution.

SECTION THREE: This Resolution shall be in full force and effect from and after its passage and approval as provided by law.

PASSED AND APPROVED BY THE PRESIDENT AND BOARD OF TRUSTEES OF THE VILLAGE OF LEMONT, COUNTIES OF COOK, WILL AND DUPAGE, ILLINOIS on this 12th day of MAY, 2014.

PRESIDENT AND VILLAGE BOARD MEMBERS:

	AYES:	NAYS:	ABSENT:	ABSTAIN
Debby Blatzer	_____	_____	_____	_____
Paul Chialdikas	_____	_____	_____	_____
Clifford Miklos	_____	_____	_____	_____
Ron Stapleton	_____	_____	_____	_____
Rick Sniegowski	_____	_____	_____	_____
Jeanette Virgilio	_____	_____	_____	_____

BRIAN K. REAVES
President

ATTEST:

CHARLENE M. SMOLLEN
Village Clerk

Exhibit A

License Agreement

LICENSE AGREEMENT

This License Agreement (“**Agreement**”) is made as of this ___ day of _____, 2014 (“**Effective Date**”), by and between Village of Lemont, an Illinois municipal corporation (“**Village**”) and INTEGRITY SECURITY PERSONNEL CONCEAL CARRY, INC., an Illinois corporation (“**Licensee**”). Village and Licensee are hereinafter sometimes referred to individually as a “Party” and together as the “Parties.”

RECITALS

WHEREAS, Village is the owner of a certain facility commonly referred to as the Lemont Police Department, located at 14600 127th Street, Lemont, IL 60439 (the “**Property**”);

WHEREAS, Licensee is an Illinois corporation that provides firearm and concealed carry training, education, and instruction to Village residents and the general public;

WHEREAS, Licensee desires to use portions of the Property, specifically including the shooting range, to conduct training, educational, and instructional classes on concealed carry and firearms safety for Village residents and the general public (collectively, the “**Licensed Activities**”); and

WHEREAS, the Village has determined that this Agreement will help promote firearm safety and education; and

WHEREAS, the Village has determined that this Agreement is in the best interest of the public health, safety and welfare of the residents of the Village;

NOW, THEREFORE, in consideration of the mutual promises hereinafter set forth, and for other good and valuable consideration, the receipt and sufficiency of which are hereby acknowledged, the Parties agree as follows:

1. Incorporation of Recitals. The foregoing recitals are hereby incorporated into this Agreement, and made a part hereof, and all covenants, terms, conditions and provisions hereinafter contained shall be interpreted and construed in accordance therewith.

2. Non-Exclusive License. Village hereby grants to Licensee a non-exclusive license (“**License**”), subject to the terms, covenants and agreements hereinafter set forth, to use and have reasonable access and means of ingress and egress to, from, over, upon, and across the Village of Lemont Police Department’s shooting range (the “**Licensed Space**”), as identified and depicted on the site map attached hereto as Exhibit A, for the sole and limited purpose of conducting the Licensed Activities. The Village also hereby grants its permission to Licensee, for the purposes of the Licensed Activities, to use in common with others and on a non-exclusive basis, all other areas located in and about the Property which are used by the public generally including parking areas (the “**Common Areas**”), for a term as set forth herein, unless sooner terminated as provided elsewhere in this Agreement. The Village reserves the right, but shall be under no obligation, to enter upon the Licensed Space at any time(s) to inspect them for

compliance by Licensee with the provisions of this Agreement, to make such repairs as it shall deem necessary or advisable, and for all other lawful reasons.

3. Term. Subject to extension or termination as provided in this paragraph or paragraph 12 below, the term of this Agreement shall be for a period of one (1) year from the Effective Date of this Agreement (“**Initial Term**”), and shall thereafter automatically renew on an annual basis for successive one-year periods on the anniversary of the Effective Date (each one-year period shall be referred to as the “**Renewal Term**”), unless either Party notifies the other Party in writing, at least sixty (60) days prior to the expiration of the Initial Term or any Renewal Term, of its intention not to renew the Agreement. The Initial Term together with any Renewal Term, if and when it occurs, shall be referred to as the “**Term**.”

4. License Fee. In consideration of the License granted Licensee under this Agreement, Licensee shall pay a fee to Village in the amount of twenty dollars (\$20.00) for each student enrolled in any class or program offered by Licensee in connection with the Licensed Activities in the Licensed Space (“**License Fee**”). The Licensee Fee shall be paid on a monthly basis, shall include payment for each student enrolled by Licensee in the Licensed Activities during the month for which payment is being made, and shall be paid not later than the fifth (5th) day of the month immediately following the month for which payment is being made. Licensee shall track student enrollment in the Licensed Activities and shall maintain accurate records of same. Licensee shall provide this information in a written accounting to the Village, together with the payment of the License Fee to which the records relate, in order to allow the Village to confirm the amount of the License Fee. Licensee shall provide the Village access to its books, ledgers and records within five (5) days of request to do so by the Village Administrator or his designee.

If Licensee is delinquent in any payment by more than ten (10) days past the date for payment specified above, a notice will be sent to Licensee at the address set forth in this Agreement (“**Notice of Non-Payment**”). If Licensee does not satisfy any delinquent payment within five (5) days after receipt of the Notice of Non-Payment, the Village shall have the option to terminate this Agreement immediately upon notice to Licensee.

5. Use of Licensed Space/Specified Times. Licensee shall have use of the Licensed Space for the purposes of the Licensed Activities on the dates and at the times specified in Exhibit B attached to and incorporated in this Agreement. Village reserves the right to use, or permit third parties to use, the Licensed Space at any time or times when not in use by Licensee pursuant to the schedule set forth in Exhibit B. Any rights to the Licensed Space not specifically granted to Licensee under this Agreement are reserved to Village, its successors and assigns. Any requests for alterations of the set schedule must be in writing to the Village prior to Licensee committing to the use of the Licensed Space. Licensee must receive prior approval from Village prior to scheduling any Licensed Activities on dates/times not identified on Exhibit B. Exhibit B may be modified in writing by agreement of Licensee and Village. The Parties acknowledge that Licensee may decide to cancel a scheduled use of the Licensed Space. In that event, it is essential that the Licensed Space be available for use by the Village or other persons.

Accordingly, Licensee shall inform Village immediately if it will not be using the Licensed Space on any of the dates/times scheduled for Licensee's use.

6. No Representations and Warranties. The Village shall not, and by virtue of this Agreement and the License granted hereunder does not, sanction, endorse, or promote Licensee or the Licensed Activities in any manner whatsoever. The Village makes no representations, guarantees, or warranties, expressed or implied, as to the accuracy, completeness, content, currency, and suitability of Licensee or the Licensed Activities. The Village specifically disclaims any and all liability for any claims or damages that may result from Licensee's acts or omissions in its performance of the Licensed Activities.

7. Condition of the Licensed Space; Duty of Care.

A. Licensee (i) has examined the Licensed Space prior to execution of this Agreement and is satisfied with its condition; (ii) acknowledges that no representation as to the condition or repair thereof has been made by the Village other than as expressly contained in this Agreement; (iii) acknowledges that no agreement or promise to alter, repair or improve the Licensed Space, other than as expressly contained in this Agreement, has been made by the Village; and (iv) agrees to return to the Licensed Space to Village, in a condition as good or better then when first used by Licensee, reasonable wear and tear excepted.

B. At all times during the License Term, Licensee shall maintain the Licensed Space, and all fixtures, equipment, machinery and other personal property located thereon and therein in good repair and in a clean, neat, orderly, healthy and safe condition, as determined by Village in its sole discretion.

C. Licensee shall be responsible for the proper disposal of all trash and garbage in containers provided by the Village for Licensee's use in the garbage storage areas of the Licensed Space. Licensee shall be responsible for the sanitation of such containers. The Village shall provide for hauling the trash and garbage from the Licensed Space.

D. Licensee shall permit inspection of the Licensed Space by authorized representatives of state, county or local departments of public health or any other agency exercising similar jurisdiction, and shall promptly and fully comply with any recommendations or requirements of same; and shall be solely responsible for any fines or citations issued in connection therewith.

E. Licensee shall not make or permit any repairs, alterations, or installations to the Licensed Space without prior written permission from the Village. Any equipment installation by Licensee shall be in accordance with applicable building codes, health ordinances, and any conditions imposed by the Village. Any remodeling or repairs required as a result of the installation or removal of any equipment shall be completed only with the Village's prior written consent and at Licensee's sole cost and expense to the satisfaction of the Village. All improvements, fixtures and personal property located in, on or affixed to the Licensed Space prior to Licensee's first entrance therein, are and shall remain the property of the Village.

Alterations, improvements and fixtures made or installed by Licensee shall become the property of the Village at the end of the Term, unless the Village requires Licensee to remove same. Licensee shall be responsible for and shall pay to the Village promptly upon demand, the full cost of any restoration or repair to the Licensed Space which results from the removal of such alterations, improvements and/or fixtures.

F. Licensee shall be responsible for all damage caused by Licensee and its employees, agents, members, volunteers or invitees to any of Village's improvements, furniture, fixtures, equipment, and personal property located in or about the Licensed Space, ordinary wear and tear excepted. Licensee shall also be responsible for any and all damage done to all or any part of the Licensed Space or the Property by Licensee and its employees, agents, members, volunteers and invitees, and Licensee shall promptly reimburse Village for the full cost or repair of all such damages or replacement. Licensee shall return the Licensed Space fixtures and equipment to Village at the termination of the Agreement in as good a condition as it received same, reasonable wear and tear excepted.

G. The Licensed Space is provided on an "as is" "where is" basis. The Village shall not provide Licensee with any equipment, materials, or supplies of any nature whatsoever in connection with the Licensed Activities. Licensee shall supply all necessary equipment, materials, and supplies.

8. Maintenance. Except for damage or misuse caused by Licensee or its employees, agents, members, volunteers or invitees or as otherwise provided in this Agreement, Village shall be responsible for maintaining the Licensed Space and its systems in good repair and for cleaning the Licensed Space as necessary for the use of the Licensed Space by persons other than Licensee and its employees, agents, members, volunteers or invitees. Notwithstanding anything to the contrary contained or implied herein, if Village determines in a particular instance, in good faith, that due to budgetary or fiscal constraints it lacks sufficient funds to perform any major repair or replacement responsibility imposed on it hereunder, Village may determine not to perform such repair/replacement and, in such event, Licensee shall have the option to terminate the License by giving prior written notice thereof to Village and, except for obligations accrued prior to the date of such termination, all obligations of the Parties under this Agreement shall thereupon cease.

9. Suspension of Use. In the event of an emergency, safety issue, or Licensee's failure to maintain insurance, or any other condition that constitutes a substantial threat to the health or safety of, or poses an increased risk of liability to Village or its officials, officers, employees, agents, invitees or others, as determined by Village in its sole reasonable discretion, Village may immediately suspend the License granted hereunder until such condition has been remedied to Village's satisfaction in accordance with this Agreement.

10. Waiver and Release of Liability. Licensee shall conduct its Licensed Activities entirely at its own risk. Licensee acknowledges that Village shall not provide any supervision, security or protection in connection with the Licensed Activities. Village shall not be liable or responsible for damage caused by fire, vandalism or other casualty to, or for the destruction,

loss, or theft of, any vehicle, equipment, material, supply or other personal property at any time during the Agreement. To the fullest extent permitted by the laws of the State of Illinois, Licensee hereby forever waives, relinquishes and discharges and holds harmless Village, and its officials, officers, employees and agents from, any and all claims of every nature whatsoever, which Licensee may have at any time against Village, its officials, officers, employees and/or agents, including without limitation claims for personal injury or property damage sustained or incurred by Licensee or any person claiming by, through or under Licensee, relating directly or indirectly to the Licensed Activities, the condition of the Licensed Space or Property, or use by Village or the Licensee of the Licensed Space or the Property.

11. Insurance. Licensee and any of its employees, agents, members, or volunteers shall procure and maintain the types and amounts of insurance, including but not limited to commercial general liability insurance, property damage, and worker's compensation insurance, as Village shall require in its sole discretion. Prior to commencement of the Licensed Activities, Licensee shall obtain and deliver to Village a certificate of insurance naming Village as an additional insured.

12. Indemnification. To the fullest extent permitted by law, Licensee shall defend, indemnify and hold harmless Village, its officers, officials, employees, agents, and volunteers and their successors and assigns, from and against any and all claims or demands of any nature whatsoever, including without limitation claims or demands for loss of, or damage to, property or for injury or death to any person from any cause whatsoever directly or indirectly arising from, related to, or connected with Licensee's use of the Licensed Space, or the conduct by Licensee of its Licensed Activities on the Property and/or Licensed Space, or the grant of License hereunder. Licensee shall pay all costs and expenses, including without limitation court costs and attorneys' fees, which shall be incurred by or imposed on Village either in enforcing the terms of this License or in any litigation or other proceeding to which Village may be made a party relating to the License or Licensee's use of the Property. Nothing herein provided is intended to waive nor shall it waive any of the immunities afforded Village under the "Local Governmental and Governmental Employees Tort Immunity Act" and Village shall continue to have all of the protections and immunities provided by said Act as now or hereafter amended.

13. Termination. The License and this Agreement may be terminated prior to their expiration under any of the following circumstances:

A. Village shall have the right to terminate this Agreement and the non-exclusive License granted hereunder immediately and without notice upon Licensee's default of its obligations hereunder, or its violation of any federal or state laws, or local regulations or ordinances. Upon the effective date of termination, the respective rights and obligations of the Parties shall cease with the exception of any obligation that accrued prior to the effective date that remains unsatisfied on the effective date, including but not limited to any obligation under Paragraphs 10, 11 and 12 above.

B. In the event Village discontinues the operation of or use of the Property or the Licensed Space for any reason whatsoever, the License shall automatically terminate. In the

event the Village suspends the operation of the Property or the Licensed Space for any reason, the License shall automatically be suspended for the same period and Licensee's obligation to pay the License Fee shall abate until such time as the Property or Licensed Space resumes operation.

C. The Village may terminate this Agreement for any reason upon fifteen (15) days advance written notice to Licensee.

In the event of termination under this Paragraph 13, all rights of Licensee and obligations of the Village shall cease. Village's right to collect sums due from Licensee under this Agreement and remedies for breach of the Agreement and Licensee's obligations to make such payments and compensate the Village for such breach shall continue after termination of this Agreement.

14. No Liability. The Village is not responsible or liable for any injury, damages or costs sustained or incurred by Licensee or to Licensee's person or property or sustained or incurred by any other person to his person or property while in or about the Licensed Space or otherwise related directly or indirectly to the License granted hereunder. Village is not liable for acts or omissions of Licensee, or any of its employees, members, agents, volunteers or other persons acting or purporting to act on behalf, at the request, or with the implied or actual consent of Licensee.

15. Compliance with Laws. Licensee shall comply with all applicable federal, state, county and local statutes, ordinances, rules, regulations and codes in the conduct of Licensed Activities, including but not limited to the Firearm Owners Identification Card Act (430 ILCS 65/0.01 *et seq.*) and the Firearm Concealed Carry Act (430 ILCS 66/1 *et seq.*). Licensee shall conduct, and cause its employees, agents, members, volunteers or invitees to conduct, the Licensed Activities in a safe manner and in strict accordance with the terms of this Agreement. Licensee shall not make or permit to be made any use of the Property or the Licensed Space which is directly or indirectly forbidden by law, ordinance, rule or regulation, or which may be dangerous to life, limb or property, or which may increase Village's insurable or uninsurable risk or liability. Licensee shall cooperate with Village and the Village's Police Department, and shall strictly follow all public safety requirements regarding its conduct of the Licensed Activities. Except as otherwise expressly provided in this Agreement, Licensee and any of its employees, agents, members, volunteers or invitees shall comply with and adhere to the general procedures, rules and regulations of Village governing application for, and license or use of, a Licensed Space. Licensee shall comply with all other applicable laws, ordinances, rules and regulations in the conduct of the Licensed Activities and its use of the Property and the Licensed Space. Village reserves the right to revise its current rules and regulations pertaining to the License or use of the Licensed Space and to promulgate such other and additional rules and regulations as in its reasonable judgment may from time to time be needed for the safety, care, cleanliness and reputation of the Property, including without limitation the Licensed Space, and for the preservation of good order therein and to ensure that its use is in conformity with all applicable laws. Provided, however, that Licensee may terminate this License

Agreement upon five (5) days prior written notice, if in the reasonable opinion of Licensee any of the rules and regulations singularly or together, effectively deny Licensee continued use of the Licensed Space as contemplated by this License and, in such event, Licensee shall be responsible only for such payments and the performance of such other obligations as shall have accrued prior to the date of termination. All rules and regulations shall be binding upon the Parties with the same force and effect as if they had been inserted herein at the time of the execution of this License Agreement.

16. No Property Interest. This Agreement and the License granted hereunder do not convey to, or create in favor of, Licensee, any legal or equitable title or property interest in whole or in part to the Licensed Space; it being acknowledged that this Agreement is a license and not a lease and merely grants temporary and limited permission to Licensee to use the Licensed Space on and subject to the terms and conditions hereof. Licensee expressly acknowledges and agrees that any statute or ordinance relating to landlord/tenant matters or forcible entry and detainer is not applicable to this Agreement and Licensee expressly waives any and all rights to which Licensee might otherwise be entitled under said laws.

17. Written Notices. All notices, requests, demands, payments, or other communications with respect to this Agreement shall be in writing and shall be deemed to have been duly given upon personal delivery or, if mailed, seventy-two (72) hours after deposit in the United States mail, certified mail, return receipt requested, with proper postage prepaid and addressed as follows (or to such other persons or addressees as may be designated by notice given to the other Party in accordance with this Paragraph 17).

To Licensee:

To Village:

Village of Lemont
418 Main Street
Lemont, Illinois 60439
Attn: Village Administrator

With a copy to:

Jeffrey M. Stein
Tressler LLP
233 S. Wacker Drive, 22nd Floor
Chicago, Illinois 60606

18. Miscellaneous Provisions.

A. This Agreement sets forth the entire understanding of the Parties with respect to the subject matter hereof, and supersedes any and all previous communications and understandings, oral or written, between the Parties. This Agreement cannot be modified or amended unless in writing signed by both Parties and dated a date subsequent to the date of this Agreement.

B. The headings of the paragraphs of this Agreement are for convenience and reference only, do not form any part of the Agreement, and in no way modify, interpret or construe the meaning of any provision of this Agreement, or the intent of the Parties.

C. Nothing contained in this Agreement is intended, or shall be interpreted or construed, as creating any partnership or joint venture between the Parties, or as either expressly or implicitly providing any right, privilege or benefit of any kind whatsoever to any person or entity that is not a Party to this Agreement, or as acknowledging, establishing or imposing any legal duty or obligation on the part of either Party to any third party.

D. This Agreement shall inure to the benefit of, and be binding upon, the Parties and their respective successors and assigns; provided however that neither this Agreement nor any right, interest or obligation of Licensee under this Agreement may be assigned in whole or in part by Licensee to any third party without the prior written consent of the Village, which the Village may grant or withhold in its sole discretion.

E. This Agreement shall be governed by and construed in accordance with the laws of the State of Illinois. The Parties agree that, for the purpose of any litigation relative to this Agreement and its enforcement, venue shall be in the Circuit Court of Cook County, Illinois and the Parties consent to the *in personam* jurisdiction of said Court for any such action or proceeding.

F. Nothing contained in or implied from any provision of this Agreement, including but not limited to Paragraphs 10, 11 and 12, is intended to constitute or shall constitute a waiver of the rights, defenses and immunities provided or available to Village under applicable Illinois law, including but not limited to the Illinois Local Governmental and Governmental Employees Tort Immunity Act.

IN WITNESS WHEREOF, each of the Parties has caused this Agreement to be executed by a duly authorized officer thereof, as of the year and date first above written.

VILLAGE OF LEMONT

INTEGRITY SECURITY PERSONNEL CONCEAL
CARRY, INC.

By: _____

By: _____

Its: _____

Its: _____

Attest: _____

Attest: _____

Its: _____

Its: _____

EXHIBIT A

Site Map



© 2014 Google

Google

EXHIBIT B

Specified Dates and Times for Use of Licensed Space

Weekends Only by Appointment

Village Board

Agenda Memorandum

To: Mayor & Village Board

From: Eileen Donahue, HR Generalist

Subject: A RESOLUTION AUTHORIZING THE ICMA-RC 457 (b) LOAN PROGRAM

Date: May 9, 2014

BACKGROUND/HISTORY

In order to provide more flexibility for employees to use their deferred comp savings for needs that might arise prior to retirement, the Village would like to allow employees to request a loan from their 457 (b) accounts.

Guidelines have been put in place to protect the Village against loss in the event of a default. Employees must complete and sign payback schedules in order to receive the money. This benefit can be provided to employees at no cost to the Village.

ACTION REQUIRED

Motion to Approve Resolution

ATTACHMENTS

1. **A Resolution to amend the retirement plan to permit loans.**

RESOLUTION NO. _____

A RESOLUTION AMENDING ICMA RETIREMENT CORPORATION SECTION 457 DEFERRED COMPENSATION PLAN #303572 TO PERMIT LOANS

WHEREAS, the Village of Lemont (“Village”) has established a Section 457 Deferred Compensation Retirement Plan (“Plan”) for Village employees which serves the interest of the Village by enabling it to provide additional retirement security for Village employees, and by assisting in the attraction and retention of personnel; and

WHEREAS, the Village has determined that permitting Plan participants to take loans from the Plan will serve these objectives.

NOW, THEREFORE, BE IT RESOLVED BY THE PRESIDENT AND BOARD OF TRUSTEES AS FOLLOWS:

SECTION 1: The foregoing findings and recitals, and each of them, are hereby adopted as Section 1 of this Resolution and are incorporated by reference as if set forth verbatim herein.

SECTION 2: The Plan shall be amended to permit loans, and the Village Administrator, or his designee, is authorized to take the necessary steps and to execute the necessary documents to effectuate the amendment.

SECTION 3: This Resolution shall be in full force and effect from and after its passage as provided by law.

PASSED AND APPROVED BY THE PRESIDENT AND BOARD OF TRUSTEES OF THE VILLAGE OF LEMONT, COUNTIES OF COOK, WILL AND DUPAGE, ILLINOIS on this 12th day of May, 2014.

PRESIDENT AND VILLAGE BOARD MEMBERS:

	AYES:	NAYS:	ABSENT:	ABSTAIN
Debby Blatzer	_____	_____	_____	_____
Paul Chialdikas	_____	_____	_____	_____
Clifford Miklos	_____	_____	_____	_____
Ron Stapleton	_____	_____	_____	_____
Rick Sniegowski	_____	_____	_____	_____
Jeanette Virgilio	_____	_____	_____	_____

BRIAN K. REAVES
President

ATTEST:

CHARLENE M. SMOLLEN
Village Clerk

Proclamation

Mayor
Brian K. Reaves

Village Clerk
Charlene Smollen



Trustees

Debby Blatzer
Paul Chialdikas
Clifford Miklos
Rick Sniegowski
Ronald Stapleton
Jeanette Virgilio

WHEREAS, the Office of the Municipal Clerk, a time honored and vital part of local government exists throughout the world; and

WHEREAS, the Office of the Municipal Clerk is the oldest among public servants; and

WHEREAS, the Office of the Municipal Clerk provides the professional link between the citizens, the local governing bodies and agencies of government at other levels; and

WHEREAS, Municipal Clerks have pledged to be ever mindful of their neutrality and impartiality, rendering equal service to all; and

WHEREAS, the Municipal Clerk serves as the information center on functions of local government and community; and

WHEREAS, Municipal Clerks continually strive to improve the administration of the affairs of the Office of the Municipal Clerk through participation in education programs, seminars, workshops and the annual meetings of their state, province, county and international professional organizations; and

WHEREAS, it is most appropriate that we recognize the accomplishments of the Office of the Municipal Clerk.

NOW, THEREFORE, I, BRIAN K. REAVES, Mayor of Lemont, on behalf of the Village Board of Trustees, do hereby recognize MUNICIPAL CLERKS WEEK May 4-10 and further extend appreciation to our Municipal Clerk, Charlene Smollen and to all Municipal Clerks for the vital services they perform and their exemplary dedication to the communities they represent.

Dated at Lemont this 12th day of May, 2014.

BRIAN K. REAVES, Mayor

Attest:

CHARLENE SMOLLEN, Village Clerk

Proclamation

Mayor
Brian K. Reaves

Village Clerk
Charlene Smollen



Trustees
Debby Blatzer
Paul Chialdikas
Clifford Miklos
Rick Sniogowski
Ronald Stapleton
Jeanette Virgilio

WHEREAS, the Congress and President of the United States have designated May 15th as Peace Officers' Memorial Day, and the week in which it falls as Police Week; and

WHEREAS, the members of the Lemont Police Department of the Village of Lemont play an essential role in safe-guarding the rights and freedoms of the citizens of Lemont; and

WHEREAS, it is important that all citizens know and understand the problems, duties and responsibilities of their police department, and that members of our police department recognize their duty to serve the people by safeguarding life and property, by protecting them against violence or disorder, and by protecting the innocent against deception and the weak against oppression or intimidation; and

WHEREAS, the Lemont Police Department has grown to be a modern and scientific law enforcement agency which unceasingly provides a vital public service.

NOW, THEREFORE, I, BRIAN K. REAVES, Mayor of Lemont, on behalf of the Village Board of Trustees, call upon all citizens of Lemont to observe the week of May 11-17, 2014, as Police Week, and join in commemorating police officers, past and present, who by their faithful and loyal devotion to their responsibilities have rendered a dedicated service to their communities and, in doing so, have established for themselves an enviable and enduring reputation for preserving the rights and security of all citizens.

I FURTHER call upon all citizens of the Village of Lemont to observe Wednesday, May 15, 2014, as Peace Officers' Memorial Day in honor of those law enforcement officers who, through their courageous deeds, have lost their lives or have become disabled in the performance of duty, and let us recognize and pay respect to the survivors of our fallen heroes.

Dated at Lemont this the 12th day of May, 2014.

Attest:

BRIAN K. REAVES, Mayor

CHARLENE SMOLLEN, Village Clerk

Proclamation

Mayor
Brian K. Reaves

Village Clerk
Charlene Smollen



Trustees

Debby Blatzer
Paul Chialdikas
Clifford Miklos
Rick Sniegowski
Ronald Stapleton
Jeanette Virgilio

WHEREAS, the week of May 18-24, 2014 is celebrated as NATIONAL PUBLIC WORKS WEEK; and

WHEREAS, the public works infrastructure, facilities, and services, including water, sewer, roadways, public buildings, ground maintenance and snow removal, are of vital importance to the health, safety, and well-being of the residents of the Village of Lemont; and

WHEREAS, these essential facilities and services could not be provided without the dedicated efforts of public works professionals, including engineers, administrators, equipment operators, and skilled workers, who help ensure their safe and efficient operation; and

WHEREAS, we must give special recognition to the Public Works employees for their exemplary performance during this past winter with extreme conditions and countless hours on end of snow plowing and water main breaks, and thank them for their dedication and hard work they have done, and continue to do; and

WHEREAS, National Public Works Week, instituted as a public education campaign by the American Public Works Association in 1960, brings attention to the importance of public works in our community and recognizes the dedicated professionals who serve the public every day.

NOW, THEREFORE, I, BRIAN K. REAVES, Mayor of Lemont, on behalf of the Village Board of Trustees, hereby proclaim the week of May 18-24 as PUBLIC WORKS WEEK in the Village of Lemont and hereby join with the community to express our appreciation to the employees of the Public Works Department in recognition of their contribution to our health, safety, comfort and quality of life.

Dated at Lemont this the 12th day of May, 2014

BRIAN K REAVES, Mayor

Attest:

CHARLENE SMOLLEN, Village Clerk

Proclamation

Mayor
Brian K. Reaves

Village Clerk
Charlene Smollen



Trustees

Debby Blatzer
Paul Chialdikas
Clifford Miklos
Rick Sniegowski
Ronald Stapleton
Jeanette Virgilio

WHEREAS, the Law Enforcement Torch Run is the single largest year-round fundraising event benefitting the Special Olympics Illinois; and

WHEREAS, the annual intrastate relay and its various fundraising projects, including "Cops on the Roof Top," raise money and gain awareness for the athletes who participate in Special Olympics Illinois; and

WHEREAS, the Special Olympics program reaffirms the beliefs that with hope and dedication, we can see achievement and self-worth realized by any individual and persons with intellectual disabilities, through their involvement in Special Olympics, to show their communities that there are no limits to their potential; and

WHEREAS, the Law Enforcement Torch Run for Special Olympics Illinois, through its fundraising efforts, helps to provide for this opportunity making the potential for every Special Olympics athlete's dream to come to life.

NOW, THEREFORE, I, BRIAN K. REAVES, Mayor of Lemont, on behalf of the Village Board of Trustees, do hereby declare May 30, 2014, as COP ON THE ROOF TOP DAY in the Village of Lemont to heighten awareness and raise donations for the Law Enforcement Torch Run benefiting Special Olympics Illinois; and all residents are encouraged to support this Law Enforcement Torch Run event for the Special Olympics Illinois.

Dated at Lemont this 12th day of May, 2014.

BRIAN K. REAVES, Mayor

Attest:

CHARLENE SMOLLEN, Village Clerk

Proclamation

Mayor
Brian K. Reaves

Village Clerk
Charlene Smollen



Trustees

Debby Blatzer
Paul Chialdikas
Clifford Miklos
Rick Sniegowski
Ronald Stapleton
Jeanette Virgilio

WHEREAS, safety is the highest priority for the highways and streets of our Village and State, and the great State of Illinois is proud to be a national leader in motorcycle safety, education and awareness; and

WHEREAS, motorcycles are a common and economical means of transportation that reduces fuel consumption and road wear, and contributes in a significant way to the relief of traffic and parking congestion; and

WHEREAS, it is especially meaningful that the citizens of our Village and State be aware of motorcycles on the roadways and recognize the importance of motorcycle safety; and

WHEREAS, the members of A.B.A.T.E. of Illinois, Inc. (A Brotherhood Aimed Toward Education), continually promote motorcycle safety, education and awareness in high school drivers' education programs and to the general public in our Village and State; and

WHEREAS, during the month of May, all roadway users should unite in the safety of roadways within the Village of Lemont and throughout the great State of Illinois.

*NOW, THEREFORE, I, BRIAN K. REAVES, Mayor of Lemont, on behalf of the Village Board of Trustees, in recognition of 27 years of ABATE of Illinois, Inc., and in recognition of the continued role Illinois serves as a leader in motorcycle safety, education and awareness, do hereby proclaim May 2014, to be **MOTORCYCLE AWARENESS MONTH** in the Village of Lemont, and urge all motorists to join in an effort to improve safety and awareness on our streets and highways.*

Dated at Lemont this 12th day of May 2014.

BRIAN K. REAVES, Mayor

Attest:

CHARLENE SMOLLEN, Village Clerk

**2014-2015
VILLAGE BOARD MEETING CALENDAR**

2014

JUNE

9
23

JULY

14
28

AUGUST

11
25

SEPTEMBER

8
22

OCTOBER

13 – NO MEETING COLUMBUS DAY
27

NOVEMBER

10
24

DECEMBER

8
22 – NO MEETING

2015

JANUARY

12
26

February

9
23

MARCH

9
23

APRIL

13
27-NO MEETING-MAYOR'S DRIVE

MAY

11
25– NO MEETING MEMORIAL DAY

Village Board Agenda Memorandum

To: Mayor & Village Board

From: George Schafer, Village Administrator
Chris Smith, Finance Director

Subject: An Ordinance Authorizing The Issuance Of Incremental Taxes / General Sales Taxes / Revenue Sharing Receipts Alternate Revenue Source Bonds Of The Village Of Lemont, Cook, DuPage And Will Counties, Illinois, For The Purpose Of Refinancing Gateway TIF Redevelopment Project Costs, And Related Facilities, Improvements And Costs

Date: May 7, 2014

BACKGROUND/HISTORY

Interest rates on General Obligation Bonds continue to be favorable. Over the past several years the Village has taken advantage of the favorable rates by advanced refunding and/or calling bonds with a net present value savings.

The Village's General Obligation Bonds Series 2005 have a current Net Interest Cost of 4.32% and are callable September 1, 2014. The net savings to call these bonds is estimated at \$55,479. The Village's Alternate Revenue Bonds Series 2012B has a net interest cost of 4.23%; however, the principal payments do not match with the Gateway TIF structure. The estimated cost to restructure the bonds is \$51,344. Staff's recommendation would be to call the General Obligation Bonds Series 2005 and restructure the Alternative Revenue Bonds Series 2012B for a total net savings of \$4,135.

The attached ordinance begins the process of calling and restructuring the bonds. The next steps according to the timetable would be to hold a public hearing on June 23, 2104.

RECOMMENDATION

Staff recommends that the Village Board passes An Ordinance Authorizing The Issuance Of Incremental Taxes / General Sales Taxes / Revenue Sharing Receipts Alternate Revenue Source Bonds Of The Village Of Lemont, Cook, DuPage And Will Counties, Illinois, For The Purpose Of Refinancing Gateway TIF Redevelopment Project Costs, And Related Facilities, Improvements And Costs.

ORDINANCE NO. _____

AN ORDINANCE AUTHORIZING THE ISSUANCE OF INCREMENTAL TAXES / GENERAL SALES TAXES / REVENUE SHARING RECEIPTS ALTERNATE REVENUE SOURCE BONDS OF THE VILLAGE OF LEMONT, COOK, DUPAGE AND WILL COUNTIES, ILLINOIS, FOR THE PURPOSE OF REFINANCING GATEWAY TIF REDEVELOPMENT PROJECT COSTS, AND RELATED FACILITIES, IMPROVEMENTS AND COSTS

PREAMBLES

WHEREAS, the Village of Lemont, Cook, DuPage and Will Counties, Illinois (the “**Municipality**”), operates in accordance with the provisions of the Illinois Municipal Code [Section 5/1-1-1 *et seq.* of Chapter 65 of the Illinois Compiled Statutes, as supplemented and amended, including by the Local Government Debt Reform Act (collectively, the “**Act**”)] and is entitled to receive a certain distributive revenue share of proceeds of the (i) Retailers’ Occupation Taxes, Service Occupation Taxes, Use Taxes and Service Use Taxes (collectively, and subject to any prior lien or pledge, “**General Sales Taxes**”) imposed, collected and distributed pursuant to applicable law and of (ii) State of Illinois income taxes (such distributive share referred to herein as the “**Revenue Sharing Receipts**”) imposed by the State of Illinois pursuant to the Illinois Income Tax Act and distributed pursuant to the State Revenue Sharing Act, and also is entitled to receive incremental taxes derived from the Municipality’s Gateway Redevelopment Project Area (subject to any prior pledge, “**Incremental Taxes**”); and

WHEREAS, the President and Board of Trustees (the “**Corporate Authorities**”) has determined that it is advisable, necessary and in the best interests of the Municipality’s public health, safety and welfare to refinance land assembly, site preparation, including remediation, demolition, environmental studies and related work, professional and other redevelopment project costs, within or serving the Gateway Redevelopment Project Area, capitalized interest, and related facilities, improvements and costs (collectively, the “**Project**”) as originally financed by the Municipality’s Taxable General Obligation Bonds (Alternate Revenue Source), Series 2012B (the “**Prior Bonds**”) by reducing certain debt service payments and to concurrently refund at a lower interest cost the Municipality’s General Obligation Bonds (Alternate Revenue Source), Series 2005; and

WHEREAS, the estimated Municipality’s costs of refinancing and restructuring the Prior Bonds debt service, including necessary legal, financial, bond discount, printing and publication costs and other expenses preliminary to and in connection with the Project is anticipated not to exceed the sum of \$1,030,000, which is to be paid from proceeds of the hereinafter described alternate bonds, being general obligation bonds as authorized by Section 15 of the Local Government Debt Reform Act, but nevertheless expected to be paid from receipts of one or more of Incremental Taxes, General Sales Taxes and Revenue Sharing Receipts, rather than by any levy of taxes; and

WHEREAS, costs of the Project are expected to be paid from available funds

therefor and from proceeds from the sale of alternate Bonds, to be payable from one or more of General Sales Taxes, Revenue Sharing Receipts and Incremental Taxes and issued pursuant to the Act, this ordinance and one or more ordinances supplemental to this ordinance authorizing and providing for the issuance of such alternate Bonds, prescribing the details of such alternate Bonds and providing for the collection, segregation and distribution of Incremental Taxes, General Sales Taxes and Revenue Sharing Receipts derived by the Municipality in lieu of any levy of general taxes; and

WHEREAS, the Municipality has insufficient funds to pay costs of the Project and, therefore, must borrow money and issue alternate Bonds in evidence thereof, at one time or from time to time and in one or more series, up to the aggregate principal amount of \$4,750,000 for such purposes, pursuant to and in accordance with the provisions of the Act.

NOW, THEREFORE, BE IT ORDAINED BY THE PRESIDENT AND BOARD OF TRUSTEES OF THE VILLAGE OF LEMONT, COOK, DUPAGE AND WILL COUNTIES, ILLINOIS, as follows:

Section 1. Incorporation of Preambles and Determination to Issue Bonds.

The Corporate Authorities hereby find that all of the recitals contained in the preambles to this ordinance are true, complete and correct and hereby incorporate them into this Section 1 of this ordinance by this reference thereto. It is necessary and in the best interests of the Municipality to undertake the Project for the public health, safety and welfare, and that for the purpose of refinancing the Project by refunding certain of the Prior Bonds there are hereby authorized to be issued and sold, at one time or from time to time as the refunding may proceed, general obligation bonds (Incremental Taxes and/or General Sales Taxes and/or Revenue Sharing Receipts alternate revenue source(s) of the Municipality in an aggregate principal amount up to but in any event not to exceed \$1,030,000 (which may be issued at one time or from time to time as funds are applied, the “**Bonds**”). The alternate revenue source(s) to pay debt service on the Bonds are receipts of one or more of Incremental Taxes, General Sales Taxes and Revenue Sharing Receipts.

Section 2. Publication and Notice. After the adoption of this ordinance by the Corporate Authorities, this ordinance, preceded by the notice hereinafter described, shall be published in a newspaper (as described in the Notice by Publication Act) published in Cook, DuPage and Will Counties, Illinois, and of general circulation within the Municipality, and if no petition, signed by not less than the number of electors of the Municipality being equal to the greater of (i) 7.5% of the registered voters within the Municipality or (ii) 200 of those registered voters or 15% of those registered voters, whichever is less, asking that the Project be undertaken and of issuing the alternate Bonds to pay the costs of the Project be submitted to the electors of the Municipality, is filed with the Village Clerk within thirty (30) days after the date of the publication of this ordinance, preceded by a notice conforming with the provisions of the Local Government Debt Reform Act, then this ordinance shall be in full force and effect and the Bonds shall be authorized to be issued. If such a petition is filed, an election on the question shall be held as set forth in a form of notice complying with Section 15 of the Local Government Debt Reform Act and not inconsistent with this ordinance, and this ordinance shall not become effective until such question shall have been duly approved by a majority of the votes cast on the

question at the election held as set forth in such form of notice. The Village Clerk shall have available and provide a form of petition to any person requesting one. The Village Clerk shall give notice of the foregoing provisions as set forth in substantially the form of such notice as is presented before the meeting of the Corporate Authorities at which this ordinance is adopted, subject to completion and modification to conform with the Local Government Debt Reform Act.

Section 3. Additional Ordinances. If no petition meeting the requirements of applicable law is filed as provided above in Section 2, or if the question is approved as above set forth, then the Corporate Authorities in accordance with and pursuant to the Act may adopt additional ordinances or other proceedings supplemental to or amending this ordinance, at one time or from time to time as the refinancing and restructuring may proceed, providing for the issuance and sale of up to but in any event not to exceed the amount of the alternate Bonds set forth above, prescribing the details of such alternate Bonds, and providing for a levy of taxes and the collection, segregation and distribution of one or more of Incremental Taxes, General Sales Taxes and Revenue Sharing Receipts for the payment of the alternate Bonds issued. Such additional or supplemental ordinances or other proceedings shall in all instances become effective in accordance with applicable law; and this ordinance, together with such supplemental and additional ordinances or other proceedings, shall constitute complete authority for the issuance of the alternate Bonds under applicable law.

Section 4. Severability and Repealer. If any section, paragraph, clause or provision of this ordinance shall be held invalid, the invalidity of such section, paragraph, clause or provision shall not affect any of the other provisions of this ordinance. All ordinances, resolutions or orders, or parts thereof, in conflict with the provisions of this ordinance are to the extent of such conflict hereby repealed.

Upon motion by Trustee, _____,
seconded by Trustee, _____, adopted upon roll call vote and
recorded in the Municipality's records, this ____ day of _____, 2014.

Approved: _____, 2014

(SEAL)

Village President, Village of Lemont, Illinois

Attest:

Village Clerk, Village of Lemont, Illinois

STATE OF ILLINOIS)
THE COUNTY OF COOK) SS
VILLAGE OF LEMONT)

CERTIFICATION OF ORDINANCE

I, the undersigned, do hereby certify that I am the duly selected, qualified and acting Village Clerk of the Village of Lemont, Cook, DuPage and Will Counties, Illinois (the “**Municipality**”), and as such official I am the keeper of the records and files of the Municipality and of its President and Board of Trustees (the “**Corporate Authorities**”).

I do further certify that the attached constitutes a full, true and complete excerpt from the proceedings of the regular meeting of the Corporate Authorities held on the ____ day of _____, 2014, insofar as same relates to the adoption of Ordinance No. _____, entitled:

AN ORDINANCE AUTHORIZING THE ISSUANCE OF INCREMENTAL TAXES / GENERAL SALES TAXES / REVENUE SHARING RECEIPTS ALTERNATE REVENUE SOURCE BONDS OF THE VILLAGE OF LEMONT, COOK, DUPAGE AND WILL COUNTIES, ILLINOIS, FOR THE PURPOSE OF FINANCING GATEWAY TIF REDEVELOPMENT PROJECT COSTS, AND RELATED FACILITIES, IMPROVEMENTS AND COSTS

a true, correct and complete copy of which ordinance (the “**ordinance**”) as adopted at such meeting appears in the transcript of the minutes of such meeting and is hereto attached.

I do further certify that the deliberations of the Corporate Authorities on the adoption of such ordinance were taken openly, that the adoption of such ordinance was duly moved and seconded, that the vote on the adoption of such ordinance was taken openly and was preceded by a public recital of the nature of the matter being considered and such other information as would inform the public of the nature of the business being conducted, that such meeting was held at a specified time and place convenient to the public, that the agenda for such meeting was duly posted on the Municipality’s website and at the office of City Clerk with all pages continuously visible and readable to the outside at street level 24/7 at least 48 hours before the meeting, that notice of such meeting was duly given to all of the news media requesting such notice, that such meeting was called and held in strict compliance with the provisions of the open meeting laws of the State of Illinois, as amended, and the Illinois Municipal Code, as amended, and that the Corporate Authorities have complied with all of the applicable provisions of such open meeting laws and such Code and their procedural rules in the adoption of such ordinance. [] petition(s) have been received as mentioned in Section 2 of such ordinance, forms thereof being at all relevant times available therefor in the City Clerk’s office.

IN WITNESS WHEREOF, I hereunto affix my official signature and the seal of the Village of Lemont, Illinois, this ____ day of _____, 2014.

(SEAL)

Village Clerk

(form of notice)

**NOTICE OF INTENT TO ISSUE BONDS
AND RIGHT TO FILE PETITION**

Notice is hereby given that pursuant to an authorizing ordinance adopted _____, 2014 (the “**Ordinance**”), the Village of Lemont, Cook, DuPage and Will Counties, Illinois (the “**Municipality**”), intends to issue its alternate bonds (the “**Bonds**”) at one time or from time to time as funds are needed up to the amount of but in any event not to exceed \$ _____ in aggregate principal amount, bearing interest at not to exceed the rate limitation provided by law, for the purpose of refinancing land assembly, site preparation, including remediation, demolition, environmental studies and related work, professional and other redevelopment project costs, within or serving the Gateway Redevelopment Project Area, capitalized interest, and related facilities, improvements and costs (the “**Project**”), to reduce certain debt service payments. The Bonds are to be paid from receipts of one or more of Incremental Taxes, General Sales Taxes and Revenue Sharing Receipts (as defined in the Ordinance) as the alternate revenue source(s), and not from any levy of general taxes.

In addition, notice is hereby given that if a petition signed by not less than _____ electors of the Municipality [being equal to the greater of (i) 7.5% of the registered voters in the Municipality or (ii) 200 of those registered voters or 15% of those registered voters, whichever is less], requesting that the question of the issuance of the Bonds for the Project be submitted to the Village Clerk within thirty (30) days of the date of publication hereof and of the above Ordinance, the question of the issuance of such Bonds for the Project shall be submitted to the electors of the Municipality at the general election to be held on November 4, 2014, if such question can be and is presented at such election, and otherwise at the next election at which such question could be presented under the general election laws. A form of petition is available to any person requesting one in the Village Clerk’s office.

/s/Charlene M. Smollen
Village Clerk, Village of Lemont, Illinois

Note to publisher: The full text of the ordinance is to follow the above notice. Please check with George Schafer ((630) 243-2709) as to any blanks in the notice or ordinance. Send your publication statement to the Village of Lemont, Cook, DuPage and Will Counties, 418 Main Street, Lemont, Illinois 60439 Attention: Village Administrator, and send two certificates of publication to Evans, Froehlich & Beth, 44 Main Street, Third Floor, Champaign, Illinois, 61820.

To: Village Clerk, Village of Lemont, Cook, DuPage and Will Counties, Illinois.

PETITION

In accordance with and pursuant to Section 2 of an authorizing ordinance of the Village of Lemont, Cook, DuPage and Will Counties, Illinois (the "**Municipality**"), adopted _____, 2014, and entitled:

AN ORDINANCE AUTHORIZING THE ISSUANCE OF INCREMENTAL TAXES / GENERAL SALES TAXES / REVENUE SHARING RECEIPTS ALTERNATE REVENUE SOURCE BONDS OF THE VILLAGE OF LEMONT, COOK, DUPAGE AND WILL COUNTIES, ILLINOIS, FOR THE PURPOSE OF REFINANCING GATEWAY TIF REDEVELOPMENT PROJECT COSTS, AND RELATED FACILITIES, IMPROVEMENTS AND COSTS

each of the undersigned hereby certifies, as applicable to each, that each is an elector (a registered voter) of the Municipality, and hereby petitions and asks that the question of issuing up to \$_____ alternate bonds, payable from one or more of Incremental Taxes, General Sales Taxes and Revenue Sharing Receipts (as defined in the above ordinance) as the alternate revenue source(s), to refinance (and reduce certain debt service payments) costs of land assembly, site preparation, including remediation, demolition, environmental studies and related work, professional refinance redevelopment project costs, within or serving the Gateway Redevelopment Project Area, and related facilities, improvements and costs, as set forth in the above ordinance, be submitted to the electors of the Municipality at the general election to be held on November 4, 2014, if such question can be and is presented at such election, and otherwise at the next election at which such question could be presented under the general election laws.

<u>Print Name</u>	<u>Address</u>	<u>Village of Lemont, Illinois</u>	<u>Signature</u>
1. _____	_____	Lemont, IL	_____
2. _____	_____	Lemont, IL	_____
3. _____	_____	Lemont, IL	_____
4. _____	_____	Lemont, IL	_____
5. _____	_____	Lemont, IL	_____
6. _____	_____	Lemont, IL	_____
7. _____	_____	Lemont, IL	_____
8. _____	_____	Lemont, IL	_____
9. _____	_____	Lemont, IL	_____
10. _____	_____	Lemont, IL	_____

Statement: I, _____ [Name], of _____ [Address], of _____, Illinois, hereby state that I am now, and was at all times I circulated this petition, a U.S. Citizen over 18 years of age, that the above signatures on this sheet were signed in my presence in the Village of Lemont, Cook, DuPage and Will Counties, Illinois, and are genuine, and to the best of my knowledge and belief each of the persons so signing were at the time of signing registered voters of the Village of Lemont, Cook, DuPage and Will Counties, Illinois, and their addresses are correctly stated.

Signature

State of Illinois) The above Statement was subscribed and sworn to
) before me this ____ day of _____, 2014.
County of _____)

(SEAL) _____
Notary Public

My Commission Expires: _____

Notice

The President and Board of Trustees of the Village of Lemont, Cook, DuPage and Will Counties will hold a public hearing on _____, 2014 at 7:00 p.m. (or as soon after as practicable). The hearing will be held in the President and Board of Trustee’s meeting room at the Village Hall, 418 Main Street, in Lemont, Illinois. The purpose of the hearing will be to receive public comments on the proposal to sell bonds in the amount of up to \$1,030,000 for the purpose of refinancing (by reducing certain debt service costs) land assembly, site preparation, including remediation, demolition, environmental studies and related work, professional and other redevelopment project costs, within or serving the Gateway Redevelopment Project Area, by refunding certain prior alternate bonds.

By: /s/ Charlene M. Smollen

Title: Village Clerk

Note to Publisher: The above notice is to be published one time at least 7 days before the hearing, but not prior to 30 days before the hearing. **The publication may be in the “legals” or “classified” section of the paper. NO SPECIAL BORDER IS REQUIRED FOR THIS PUBLICATION. DO NOT USE ANY SPECIAL BORDER.** Please send your statement to:

Village of Lemont
418 Main Street
Lemont, Illinois 60439
Attn: Village Administrator

and send two publication certificates (and text) to Evans, Froehlich, Beth & Chamley, 44 E. Main Street, Suite 310, Champaign, Illinois 61820-3649.

PUBLISHER: DO NOT PRINT THE FOLLOWING:

Village President’s Approval and Order Setting Public Hearing:

The undersigned, Village President of the above Municipality hereby approves and orders the setting of the above Bond Issue Notification Act hearing.

Date: _____, 2014

Village President

When signed by the Village President, please fax back to Evans, Froehlich, Beth & Chamley at 217/359-6468 and file with the Village Clerk.

Village of Lemont, Cook, DuPage and Will Counties, Illinois

\$980,000 Taxable General Obligation Refunding Bonds (ARS), Series 2014A (TIF)
\$970,000 General Obligation Refunding Bonds (ARS), Series 2014B (Sales Tax)

PROPOSED TIMETABLE

TENTATIVE CLOSING: September 3, 2014

DATE:		✓	STEP IN PROCEDURE:
1.	Monday, April 21, 2014		COMMITTEE OF THE WHOLE MEETING: Bernardi Securities, Inc. presents refinancing and restructuring summaries to the Village Board.
2.	Monday, May 12, 2014		VILLAGE BOARD MEETING: Village declares intent to proceed with refunding its outstanding Bonds and also passes Authorizing Ordinance to start the 30-day petition period. Engagement letter with Bernardi Securities, Inc is approved.
3.	Week of May 12, 2014		Bernardi Securities, Inc. begins preparing preliminary documents and publishing Authorizing Ordinance/BINA Hearing in local newspaper.
6.	Monday, June 16, 2014		30-day petition period expires.
5.	Monday, June 23, 2014		VILLAGE BOARD MEETING: Village holds BINA Hearing prior to regularly scheduled Board meeting.
	Tuesday, July 15, 2014		Preliminary Official Statement (POS) is released to the Village for review.
7.	Tuesday, July 22, 2014		Moody's Rating Agency Call with Village and Bernardi Securities. Due Diligence Call with Disclosure Counsel and Village follows.
7.	Monday, July 28, 2014		Moody's Rating received on the Bonds.
9.	Monday, July 28, 2014		VILLAGE BOARD MEETING: Village passes Parameters Bond Ordinance for the Bonds. Bernardi Securities, Inc. presents preliminary pricing summary to Village Board.
11.	Friday, August 01, 2014		Preliminary Official Statement is finalized.
12.	Friday, August 08, 2014		Bernardi Securities, Inc. and Village staff discuss timing and preliminary interest rates.
7.	Monday, August 11, 2014		Bernardi Securities, Inc. begins pre-order selling period for local buyers. Bernardi Securities, Inc. contacts local institutional/retail investors.
8.	Friday, August 15, 2014		Final Pricing
	Friday, August 15, 2014		Bond Purchase Agreement is signed and final savings and interest rates are locked in.
10.	Wednesday, September 03, 2014		Closing. Bernardi Securities, Inc. coordinates with Bond Counsel & Paying Agent.

BERNARDISECURITIES^{LLC}

MUNICIPAL BOND SPECIALISTS

VILLAGE OF LEMONT, Cook, DuPage and Will Counties, Illinois

ESTIMATED DEBT SERVICE SAVINGS - Level for General Obligation Bonds (Sales Tax ARS), Series 2005 (as of April 9, 2014)

<i>Before Refunding</i>				<i>After Refunding (Alternate Bonds)</i>					
Year	Principal (12/1)	Interest (6/1 & 12/1)*	Total Debt Service	Year	Principal (12/1)	Interest (6/1 & 12/1)	2005 Existing Debt Service	Total Debt Service	Estimated Savings
2014	\$ 75,000	\$ 21,384	\$ 96,384	2014	\$ -	\$ 5,772	\$ 90,612	\$ 96,383	0
2015	80,000	39,993	119,993	2015	90,000	23,088	-	113,088	6,905
2016	80,000	36,873	116,873	2016	90,000	21,288	-	111,288	5,585
2017	85,000	33,753	118,753	2017	95,000	19,488	-	114,488	4,265
2018	85,000	30,268	115,268	2018	90,000	17,588	-	107,588	7,680
2019	90,000	26,783	116,783	2019	95,000	15,788	-	110,788	5,995
2020	95,000	22,958	117,958	2020	95,000	13,888	-	108,888	9,070
2021	100,000	18,920	118,920	2021	100,000	11,845	-	111,845	7,075
2022	105,000	14,520	119,520	2022	105,000	9,345	-	114,345	5,175
2023	110,000	9,900	119,900	2023	105,000	6,405	-	111,405	8,495
2024	110,000	4,950	114,950	2024	105,000	3,308	-	108,308	6,643
2025	-	-	-	2025	-	-	-	-	-
2026	-	-	-	2026	-	-	-	-	-
2027	-	-	-	2027	-	-	-	-	-
	<u>\$ 1,015,000</u>	<u>\$ 260,299</u>	<u>\$ 1,275,299</u>		<u>\$ 970,000</u>	<u>\$ 147,799</u>	<u>\$ 90,612</u>	<u>\$ 1,208,411</u>	<u>\$ 66,888</u>

Net Interest Cost..... 4.32%

Net Interest Cost..... 2.61%

Total Combined Net Savings: \$ 66,888

Present Value Savings (\$)..... \$ 55,479

Present Value Savings (%)..... 5.90%

* Assumes June 1, 2014 payment on 2005 Bonds.

As of April 9, 2014. Moody's "Aa2" Rated, Bank-Qualified - all estimated costs of issuance included. Dated September 1, 2014.

BERNARDISECURITIES

MUNICIPAL BOND SPECIALISTS

VILLAGE OF LEMONT, Cook, DuPage and Will Counties, Illinois

ESTIMATED DEBT RESTRUCTURING

for

Taxable General Obligation Bonds (ARS), Series 2012B - Gateway TIF

(as of April 9, 2014)

<i>Before Refunding (2012B Bonds)</i>				<i>After Refunding (2012B & 2014 Bonds)</i>						
Year Ending January 1,	Principal (1/1)	Interest (1/1 & 7/1)*	Total Debt Service	Year Ending January 1,	2012B Principal (1/1)	2012B Interest (1/1 & 7/1)	2014 Principal (1/1)	2014 Interest (1/1 & 7/1)	Total Debt Service	Difference
2014	\$ -	\$ -	\$ -	2014	\$ -	\$ -	\$ -	\$ -	\$ -	-
2015	295,000	93,610	388,610	2015	-	79,960	-	13,365	93,325	295,285
2016	300,000	178,370	478,370	2016	-	159,920	-	40,095	200,015	278,355
2017	315,000	169,370	484,370	2017	-	159,920	-	40,095	200,015	284,355
2018	325,000	159,920	484,920	2018	325,000	159,920	15,000	40,095	540,015	(55,095)
2019	330,000	150,170	480,170	2019	330,000	150,170	30,000	39,645	549,815	(69,645)
2020	345,000	138,620	483,620	2020	345,000	138,620	35,000	38,745	557,365	(73,745)
2021	360,000	124,820	484,820	2021	360,000	124,820	75,000	37,695	597,515	(112,695)
2022	370,000	110,420	480,420	2022	370,000	110,420	90,000	35,445	605,865	(125,445)
2023	385,000	95,620	480,620	2023	385,000	95,620	115,000	32,115	627,735	(147,115)
2024	405,000	79,450	484,450	2024	405,000	79,450	130,000	27,515	641,965	(157,515)
2025	420,000	61,630	481,630	2025	420,000	61,630	145,000	22,120	648,750	(167,120)
2026	440,000	42,310	482,310	2026	440,000	42,310	165,000	15,885	663,195	(180,885)
2027	460,000	21,850	481,850	2027	460,000	21,850	180,000	8,460	670,310	(188,460)
2028	-	-	-	2028	-	-	-	-	-	-
	\$ 4,750,000	\$ 1,426,160	\$ 6,176,160		\$ 3,840,000	\$ 1,384,610	\$ 980,000	\$ 391,275	\$ 6,595,885	\$ (419,725)

Net Interest Cost..... 4.23%

Net Interest Cost..... 4.36%

Net Present Value Savings:..... (51,344)

* Assumes 7/1/2014 Interest Payment is made on 2012B Bonds.

As of April 3, 2014. Moody's "Aa2" Rated, Taxable Rates - all estimated costs of issuance included. Dated September 1, 2014.

AN ACT concerning government.

**Be it enacted by the People of the State of Illinois,
represented in the General Assembly:**

Section 5. The Open Meetings Act is amended by changing Section 2.02 as follows:

(5 ILCS 120/2.02) (from Ch. 102, par. 42.02)

Sec. 2.02. Public notice of all meetings, whether open or closed to the public, shall be given as follows:

(a) Every public body shall give public notice of the schedule of regular meetings at the beginning of each calendar or fiscal year and shall state the regular dates, times, and places of such meetings. An agenda for each regular meeting shall be posted at the principal office of the public body and at the location where the meeting is to be held at least 48 hours in advance of the holding of the meeting. A public body that has a website that the full-time staff of the public body maintains shall also post on its website the agenda of any regular meetings of the governing body of that public body. Any agenda of a regular meeting that is posted on a public body's website shall remain posted on the website until the regular meeting is concluded. The requirement of a regular meeting agenda shall not preclude the consideration of items not specifically set forth in the agenda. Public notice of any

special meeting except a meeting held in the event of a bona fide emergency, or of any rescheduled regular meeting, or of any reconvened meeting, shall be given at least 48 hours before such meeting, which notice shall also include the agenda for the special, rescheduled, or reconvened meeting, but the validity of any action taken by the public body which is germane to a subject on the agenda shall not be affected by other errors or omissions in the agenda. The requirement of public notice of reconvened meetings does not apply to any case where the meeting was open to the public and (1) it is to be reconvened within 24 hours, or (2) an announcement of the time and place of the reconvened meeting was made at the original meeting and there is no change in the agenda. Notice of an emergency meeting shall be given as soon as practicable, but in any event prior to the holding of such meeting, to any news medium which has filed an annual request for notice under subsection (b) of this Section.

(b) Public notice shall be given by posting a copy of the notice at the principal office of the body holding the meeting or, if no such office exists, at the building in which the meeting is to be held. In addition, a public body that has a website that the full-time staff of the public body maintains shall post notice on its website of all meetings of the governing body of the public body. Any notice of an annual schedule of meetings shall remain on the website until a new public notice of the schedule of regular meetings is approved.

Any notice of a regular meeting that is posted on a public body's website shall remain posted on the website until the regular meeting is concluded. The body shall supply copies of the notice of its regular meetings, and of the notice of any special, emergency, rescheduled or reconvened meeting, to any news medium that has filed an annual request for such notice. Any such news medium shall also be given the same notice of all special, emergency, rescheduled or reconvened meetings in the same manner as is given to members of the body provided such news medium has given the public body an address or telephone number within the territorial jurisdiction of the public body at which such notice may be given. The failure of a public body to post on its website notice of any meeting or the agenda of any meeting shall not invalidate any meeting or any actions taken at a meeting.

(c) Any agenda required under this Section shall set forth the general subject matter of any resolution or ordinance that will be the subject of final action at the meeting. The public body conducting a public meeting shall ensure that at least one copy of any requested notice and agenda for the meeting is continuously available for public review during the entire 48-hour period preceding the meeting. Posting of the notice and agenda on a website that is maintained by the public body satisfies the requirement for continuous posting under this subsection (c). If a notice or agenda is not continuously available for the full 48-hour period due to actions outside of

Public Act 097-0827

HB4687 Enrolled

LRB097 16461 JDS 61625 b

the control of the public body, then that lack of availability
does not invalidate any meeting or action taken at a meeting.

(Source: P.A. 94-28, eff. 1-1-06.)



Village of Lemont
Planning & Economic Development Department

418 Main Street · Lemont, Illinois 60439
phone 630-257-1595 · fax 630-257-1598

TO: Mayor Reaves
Village Board of Trustees

FROM: Charity Jones, AICP, Planning & Economic Development Director

SUBJECT: 431 Talcott Ave – grant agreement

DATE: May 8, 2014

SUMMARY

When Pollyanna Brewing was considering Lemont as the site for its brewery, the business and the Village engaged in incentive negotiations, during which the Village offered a matching grant not to exceed \$25,000 for certain necessary site improvements. Jerry Kulhanek, owner of the subject property, has submitted a grant application for this work, with a total grant amount of \$23,723.50. Because the property is within the Downtown TIF District, TIF funds are being used for the grant. It is not, however, a traditional TIF façade grant therefore the ordinance designates the grant as an economic development grant.

BOARD ACTION

Vote on the attached ordinance.

ATTACHMENTS

1. An Ordinance Approving an Economic Development Grant for 431 Talcott Avenue in Lemont, IL.

**VILLAGE OF LEMONT
ORDINANCE NO. _____**

**AN ORDINANCE APPROVING AN ECONOMIC DEVELOPMENT GRANT FOR
431 TALCOTT AVENUE IN LEMONT, IL**

**ADOPTED BY THE
PRESIDENT AND THE BOARD OF TRUSTEES
OF THE VILLAGE OF LEMONT
THIS 12TH DAY OF MAY, 2014**

**Published in pamphlet form by
Authority of the President and
Board of Trustees of the Village of
Lemont, Counties of Cook, Will and
DuPage, Illinois, this 12th day of May, 2014**

ORDINANCE NO. _____

**AN ORDINANCE APPROVING A ECONOMIC DEVELOPMENT GRANT FOR
431 TALCOTT AVENUE, LEMONT, IL**

WHEREAS, the Village of Lemont (“Village”) is an Illinois Municipal Corporation pursuant to the Illinois Constitution of 1970 and the Statutes of the State of Illinois; and

WHEREAS, Section 5/8-1-2.5 of the Illinois Municipal Code (65 ILCS 5/8-1-2.5) provides municipalities with the authority to appropriate and expend funds for economic development purposes, including but not limited to grants that are deemed desirable for the promotion of economic development within the municipality; and

WHEREAS, the Village is desirous to promote the growth and development of certain designated commercial rehabilitation areas of the Village known as the Tax Increment Financing District; and

WHEREAS, Jerry Kulhanek, acting on behalf of 507 Talcott, LLC, owner of the subject property, has requested and applied for a grant to fund certain improvements to the property known as 431 Talcott Avenue; and

WHEREAS, the Village is committed to quality economic development projects which will serve to improve the economic base in the community leading to increased business activity, development of job opportunities, enhanced equalized assessed value of property within the Village, enhanced revenue which will contribute to the cost of public services, all of which will serve to improve the health, safety, and general welfare of the businesses and residents of the Village; and

WHEREAS, the Village Board of Trustees hereby finds that the described improvements will generally improve the previously vacant property and enable it to be occupied by a microbrewery, the operation of which is anticipated to have a positive local economic impact; and

WHEREAS, this grant is administered by the Village and is funded from District Revenues for purposes of control and prevention of blight, dilapidation and deterioration of designated areas within the District, and

WHEREAS, the Village has agreed to participate, subject to its sole discretion, in sharing the costs of downtown building, sign, and site improvements to commercial establishments within the District; and

WHEREAS, the property is located within the Tax Increment Financing District/Downtown, a designated rehabilitation area, and the owner has requested and applied for a grant pursuant to the terms and provisions of this agreement.

WHEREAS, the Village Board of Trustees has recommended a maximum grant amount of \$23,723.50.

NOW, THEREFORE BE IT ORDAINED BY THE PRESIDENT AND BOARD OF

TRUSTEES OF THE VILLAGE OF LEMONT, COUNTIES OF COOK, DUPAGE, AND WILL, ILLINOIS:.

Section 1: The statements set forth in the preamble to this Ordinance are found to be true and correct and are incorporated into this Ordinance as if set forth in full.

Section 2: That the President be and is hereby authorized and directed, and the Village Clerk is directed to attest to the document known as “Downtown Lemont Economic Development Grant Agreement” for 431 Talcott Avenue, a copy of which is attached hereto as Exhibit A and made a part hereof.

Section 3: That this ordinance shall be in full force and effect from and after its passage, approval and publication in pamphlet form as provided by law.

PASSED AND APPROVED BY THE PRESIDENT AND BOARD OF TRUSTEES OF THE VILLAGE OF LEMONT, COUNTIES OF COOK, WILL, AND DUPAGE, ILLINOIS, on this 12th day of May, 2014.

PRESIDENT AND VILLAGE BOARD MEMBERS:

	AYES:	NAYS:	ABSENT:	ABSTAIN
Debby Blatzer	_____	_____	_____	_____
Paul Chialdikas	_____	_____	_____	_____
Clifford Miklos	_____	_____	_____	_____
Rick Sniegowski	_____	_____	_____	_____
Ron Stapleton	_____	_____	_____	_____
Jeanette Virgilio	_____	_____	_____	_____

BRIAN K. REAVES
President

ATTEST:

CHARLENE M. SMOLLEN
Village Clerk

Exhibit A

Economic Development Grant Agreement for 431 Talcott Avenue

**VILLAGE OF LEMONT
ECONOMIC DEVELOPMENT GRANT AGREEMENT**

THIS AGREEMENT (hereinafter referred to as "Agreement"), entered into this 12th day of May, 2014, between the Village of Lemont, Illinois (hereinafter referred to as the "VILLAGE") and the following designated OWNER/LESSEE, to wit:

Owner's/Lessee's Name: 507 Talcott, LLC

Address: 8525 Kearney Rd.

City: Downers Grove State: Illinois Zip Code: 60516

Name of Business: n/a

Project Address(es): 431 Talcott Ave, Lemont

WITNESSETH

WHEREAS, Section 5/8-1-2.5 of the Illinois Municipal Code (65 ILCS 5/8-1-2.5) provides municipalities with the authority to appropriate and expend funds for economic development purposes, including but not limited to grants that are deemed desirable for the promotion of economic development within the municipality; and

WHEREAS, the Village is committed to quality economic development projects which will serve to improve the economic base in the community leading to increased business activity, development of job opportunities, enhanced equalized assessed value of property within the Village, enhanced revenue which will contribute to the cost of public services, all of which will serve to improve the health, safety, and general welfare of the businesses and residents of the Village; and

WHEREAS, the Village Board of Trustees hereby finds that the described improvements will generally improve the previously vacant property and enable it to be occupied by a microbrewery, the operation of which is anticipated to have a positive local economic impact; and

WHEREAS, the VILLAGE is desirous to promote the growth and development of certain designated commercial rehabilitation areas of the VILLAGE known as the Tax Increment Financing District; and

WHEREAS, this grant is administered by the VILLAGE and is funded from District Revenues for purposes of control and prevention of blight, dilapidation and deterioration of designated areas within the District, and

WHEREAS, the VILLAGE has agreed to participate, subject to its sole discretion, in sharing the costs of downtown building, sign, and site improvements to commercial establishments within the District; and

WHEREAS, the OWNER's/LESSEE's property is located within the Tax Increment Financing District/Downtown, a designated rehabilitation area, and the OWNER/LESSEE has requested and applied for a grant pursuant to the terms and provisions of this agreement.

NOW, THEREFORE, in consideration of the mutual covenants and agreement obtained herein, the VILLAGE and OWNER/LESSEE do hereby agree as follows:

Section 1. COST SHARING. The VILLAGE shall reimburse the OWNER/LESSEE for fifty percent of the costs for property improvements as described in Exhibit A to the OWNER's/LESSEE's property, and as reviewed and approved for a Certificate of Appropriateness by the Lemont Historic Preservation Commission. **The maximum amount of reimbursement for said property improvements shall not exceed \$23,723.50.**

Section 2. PLAN APPROVAL. No building, sign, or site improvement shall be undertaken until the building, sign, and/or site plans have been submitted to and approved by the VILLAGE. Following approval, the OWNER/LESSEE shall cause all such improvements to be completed within 180 days of the date of the approval of this Agreement.

Section 3. REVIEW OF PROJECT. The Planning & Economic Development Director shall periodically review the progress of the contractor's work on the building, sign, and site improvements pursuant to this Agreement. Such inspections shall not replace any required permit inspection by Village Inspectors. All work which is not in conformance with the approved drawings and specifications shall be immediately remedied by the OWNER/LESSEE and deficient or improper work shall be replaced and made to comply with the approved drawings, specifications, and terms of this Agreement.

Section 4. DOCUMENTATION REQUIREMENTS. Upon completion of the building and site improvement/historic preservation and upon its final inspection and approval by the Building Department, the OWNER/LESSEE shall submit to the VILLAGE a properly executed and notarized contractor statement and architect fee statement showing the full cost of the work as well as each separate component amount due to the contractor and each and every subcontractor involved in furnishing labor, materials, or equipment in the work.

In addition, the OWNER/LESSEE shall submit to the VILLAGE proof of payment of the contract cost pursuant to the contractor's and architect's statements. The VILLAGE shall, within sixty days of receipt of the contractor's statement and proof of payment issue a check to the OWNER/LESSEE. In no case shall the amount paid to the OWNER/LESSEE exceed the amount specified in this Agreement or in the contractor's or architect's statements. At the time of reimbursement and throughout the term of this agreement, the land use and signage under the control of the OWNER/LESSEE shall be in conformance with zoning and sign code provisions.

Section 5. FAILURE TO COMPLETE WORK. If the OWNER/LESSEE or his contractor fails to complete the building, sign, or site improvements in conformity with the plans provided for in Exhibit A and in conformity with the provisions of this Agreement, this Agreement shall terminate and the financial obligation on the part of the VILLAGE shall cease and become null and void.

Section 6. UNRELATED IMPROVEMENTS. Nothing herein is intended to limit,

restrict or prohibit the OWNER/LESSEE from undertaking any other work in or about the subject premises which is unrelated to the building, sign, and site improvement provided for in this Agreement.

Section 7. VILLAGE INDEMNIFICATION REGARDING CONSTRUCTION. The OWNER/LESSEE of the Subject Property agree to defend and hold harmless the Village from any and all claims which may arise out of this grant and the construction activities under this Agreement.

Section 8. GENERAL INDEMNIFICATION. In the event that, as a result of this Agreement, or actions taken as required hereunder, the VILLAGE is made a party defendant in any litigation arising by reason of this Agreement, and development activities contemplated hereunder, the OWNER/LESSEE agree to defend and hold harmless the VILLAGE, the mayor, trustees, officers and agents thereof, individually and collectively, from any suits and from any claims, demands, setoff or other action including but not limited to judgments arising therefrom. The obligation of the OWNER/LESSEE hereunder shall include and extend to payment of reasonable attorneys' fees for the representation of the VILLAGE and its officers and agents in such litigation and includes expenses, court costs and fees; it being understood that the OWNER/LESSEE where there shall be no applicable standards provided therein, shall have the right to employ all such attorneys to represent the VILLAGE and its officers and agents in such litigation, subject to the approval of the corporate authorities of the VILLAGE, which approval shall not be unreasonably withheld. The OWNER/LESSEE shall have the right to appeal to courts of appellate jurisdiction any judgment taken against the VILLAGE or its officers or agents in this respect, and the Village shall join in any such appeal taken by the OWNER/LESSEE.

Section 9. PERFORMANCE OF AGREEMENT. It is agreed that the parties hereto may in law or in equity, by suit, action, mandamus, or any other proceeding, including specific performance, enforce or compel the performance of this Agreement, which shall include the right of the parties to recover a judgment for monetary damages against each other, provided, however, that the OWNER/LESSEE shall not have a right to recover a judgment for monetary damages against any elected or appointed official of the VILLAGE for any breach of any of the terms of this Agreement. The VILLAGE reserves the right to maintain an action to recover damages or any sums which OWNER/LESSEE have agreed to pay pursuant to this Agreement and which have become due and remained unpaid.

Section 10. EXHIBITS. It is agreed that Exhibit A shall be considered part of this agreement.

Section 11. DISPLAY OF VILLAGE FUNDING PROMOTIONAL MATERIAL. The OWNER/LESSEE hereby agrees to prominently display a poster identifying the property as receiving VILLAGE funding under a grant. The sign will be provided by the VILLAGE and shall be displayed upon approval of this Agreement to no less than thirty days after final approval and reimbursement is made.

IN WITNESS THEREOF, the parties hereto have executed this Agreement on the date first appearing above.

OWNER/LESSEE

VILLAGE OF LEMONT

Property OWNER/LESSEE

Village President

Date: _____

Date: _____

ATTEST:

By: _____
Village Clerk

Application for Downtown Façade, Sign, and Site Improvement Grant

APPLICANT INFORMATION

Applicant's Name ZAKUL LLC

Applicant's Address 8525 Kearney Rd Downers Grove IL 60516

Applicant's Telephone # 773-908-2015

Applicant's E-mail Address JK@bortleslemont.com

CHECK ONE OF THE FOLLOWING:

- Applicant is the owner of the subject property and is the signer of this application.
- Applicant is the contract purchaser of the subject property.
- Applicant is acting on behalf of the beneficiary of a trust.
- Applicant is a tenant on the subject property.

PROPERTY INFORMATION

Address of Subject Property/Properties 427-431 Talcott

Parcel Identification Number of Subject Property/Properties _____

PROJECT INFORMATION

Brief description of the proposed work (attach additional sheets if necessary)

Build out of unit. Exterior Site modifications, Fire Protection installation and modification, Alarm installation, sign.

Estimated project costs

\$500,000 (ITEMS Applicable for Grant \$47,447)

Application for Downtown Façade, Sign and Site Improvement Grant, page 2 of 2

Village of Lemont

APPLICATION FEE AND SUPPORTING DOCUMENTS

- Application fee is \$30.00 for each application; ATTACH CHECK MADE OUT TO "VILLAGE OF LEMONT"
- Attach architectural elevations, plans, site plans, etc. as appropriate
- Attach contractor proposals, quotes

FOR VILLAGE STAFF USE ONLY

Application received on: _____ By: _____
 Fee amount received: _____

Eligibility requirements:

- Commercial establishment A13Project location within Downtown TIF
- Total project cost exceeds \$2,000
- Applicant is owner/tenant
- Project is for one or more of the following: exterior work, window, doors, lighting, roofing, signs, landscaping, parking lots, driveways, sidewalks, utility hook-up, fire suppression system/alarm

AFFIRMATION

I hereby affirm that I have full legal capacity to authorize the filing of this application and that all information, exhibits, and documents herewith submitted are true and correct to the best of my knowledge. I permit Village representatives to make all reasonable inspections and investigations of the subject property during the period of processing of this application. I understand that the submitted fee is non-refundable, and that prior to approval of grant reimbursement I will be expected to enter into an agreement with the Village of Lemont.

 Signature of Applicant _____ Date 3-30-14

 State _____ County COOK

I, the undersigned, a Notary Public in and for the aforesaid County and State, do hereby certify that _____ is personally known to me to be the same person whose name is subscribed to the foregoing instrument, and that said person signed, sealed and delivered the above petition as a free and voluntary act for the uses and purposes set forth.

 Notary Signature _____

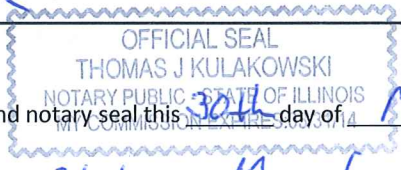

Given under my hand and notary seal this 30th day of March A.D. 20 14.
 My commission expires this 31st day of March A.D. 20 14.

lot 1

Things of Steel

March 5, 2014

Paul Ciciora
431 Talcott Avenue
Lemont, IL 60439

Pollyanna Brewing Company Sign

Description of work: Create a custom sign with the Pollyanna Brewing Company logo in 11 gauge stainless steel per discussion and CAD rendering provided. Pollyanna is to be one word while the words Brewing Company will be individual letters and the wheat will be in two segments. 5" rods will be welded to the back of each component to provide attachment to the wall with a 2" standoff.

14 foot by 21 inch Sign	\$3,200.00
Tax	\$ 192.00
Total	\$3,392.00

Things of Steel requires half down to begin work and the remainder at completion of work.

Delivery and installation not included in price.

507 Talcott Ave

Del - 520
Instll - 900

4812.00

Due to material fluctuations the pricing may change if down payment is not received by March 31, 2014.

Thank you,
Michelle and Katherine

507 Talcott LLC

PO Box 112
Lemont, IL 60439

1 of 3

April 17, 2014

Foundation Wall and Limestone Repair

Proposal No. 102010
Code:

To: Zakul LLC

Attn. Jerry

Ph. 773-908-2015

Fax.

Re: Repair of existing wall

Bid Drawings, Specifications, Addenda: Field inspection

Bid Scope of Work:

Remove existing limestone wall and rebuild. Reuse existing limestone if possible

Bid Exceptions and Clarifications:

1. Any items not included in bid scope are excluded.
-

Base Bid: \$2,400.00 (Two Thousand Four Hundred Dollars)

Bid Alternates: None

Terms and Conditions





2 of 3

3023



Proposals



TIMBERLINE LANDSCAPING

10 S. 350 Suffield
Downers Grove, IL 60516
(630) 971-2594

Date	Estimate #
4/16/2014	A- 30

Name / Address
TALLCOTT, LLC 507 TALLCOTT LEMONT, IL 60439

Project

Description	Qty	Cost	Total
507 TALLCOTT			
REMOVE AND CLEAN PAVERS			
INSTALL GRAVEL AND REGRADE AREAS			
RELAY PAVERS AND SAND AREAS			
INSTALL 4 REDTWIG DOGWOODS			
INSTALL OAK MULCH TO AREA			
TOTAL		3,600.00	3,600.00
Total			\$3,600.00

2 of 2

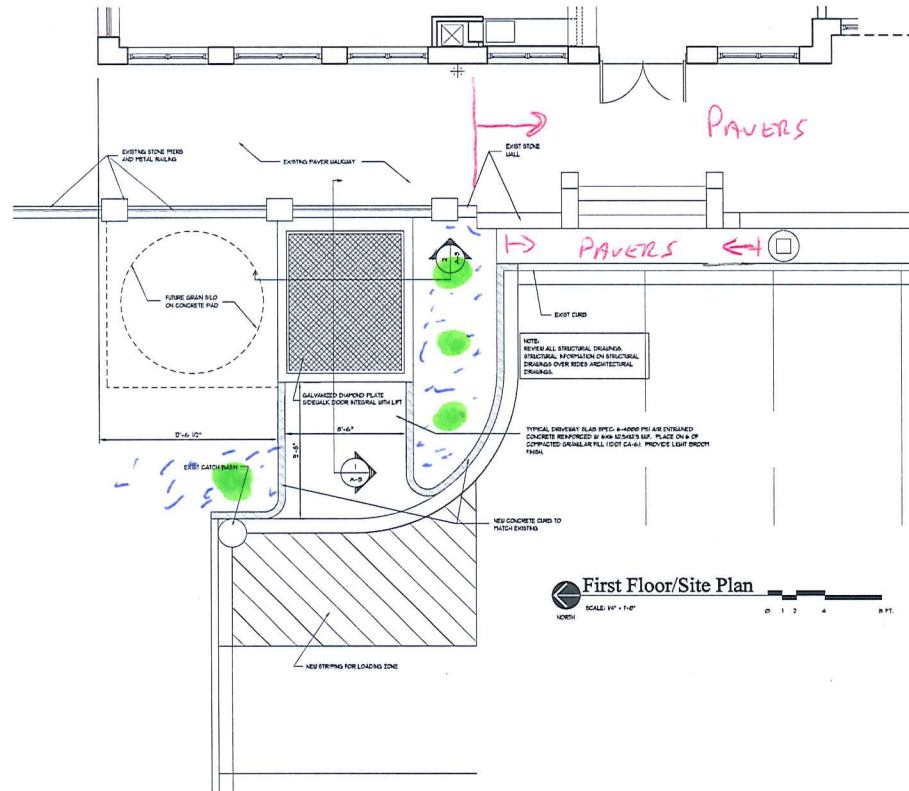

● - BUSHES

⊞ - MULCH

N
2
3
4

102



CROSS POINTS SALES, INC.

SPECIALISTS IN FIRE ALARM SYSTEMS & ALARM MONITORING

3158 S. State Street
Lockport, Illinois 60441
Office (815) 727-6585
Fax (815) 727-6586
jlehr.cpsi@sbcglobal.net

March 28, 2014

Bottles Lemont
Attn: Jerry Kulhanek

Via: jk@bottleslemont.com

PROPOSAL

Dear Mr. Kulhanek:

Thank you for allowing CPSI the opportunity to provide you with the following proposal for the fire alarm system alteration at **Pollyanna Brewing Company, 431 Talcott Ave., Lemont, IL**. The equipment to be used and scope of work is as follows:

- 1 Install NAC power expansion panel
- 1 Provide battery back-up power supply
- 4 Install visual notification devices
- 2 Install audio/visual notification devices
- Install and program devices for elevator recall
- Connect and program new devices to existing FACP

Total Cost with Installation: \$ 11,795.00

Price does not include any permit, plan review or inspection fees that may be required. Any additional equipment required after plan review or inspection is at additional cost. Price does not include dedicated power circuit for NAC panel.

All material in this contract is to be specified as above and the entire job to be done in a neat, workmanlike manner during regular business hours. Any variations from the plan or alterations requiring extra labor will be performed only upon written approval and billed in addition to the above sum covered in this contract. Agreements made with our workman are not recognized. No additional work can be performed without a written change order.

Fire Alarm System Proposal (Cont'd)
Pollyanna Brewing
Page 2 of 2
March 28, 2014

CPSI agrees to honor equipment manufacturers' warranty of one (1) year from the date of installation. Service shall include repair or replacement of defective equipment and such adjustments as are required to keep the system in satisfactory working condition, but does not include changes or additions or repairs or replacement of equipment damaged through accident, misuse, abuse, acts of God or other reasons beyond the control of CPSI.

ALL OTHER WARRANTIES, EXPRESS OR IMPLIED, INCLUDING, BUT NOT LIMITED TO, ANY IMPLIED WARRANTIES OF MERCHANTABILITY OF FITNESS FOR A PARTICULAR PURPOSE ARE HEREBY EXCLUDED.

This Agreement if for monitoring shall be for an initial term of one (1) year commencing on date of execution. This Agreement shall automatically renew for successive 1-year terms unless either party notifies the other in writing not less than 90 days prior to the expiration of any term.

In the event CPSI incurs any expenses, attorney's fees or court costs as a result of customer's failure to comply with any of the terms or conditions of this agreement, including but not limited to payment, the customer shall be solely and exclusively responsible for, and shall pay and defray, in its entirety, all of CPSI's expenses, attorney's fees and costs.

Cross Points Sales, Inc.

By: _____
Jeffrey G. Lehr

Acceptance of the above specifications, terms and contract are satisfactory and I (We) hereby authorize the performance of this work:

Date: _____

By: _____
Name/Title

THIS CONTRACT IS VOID 30 DAYS FROM THE DATE UNLESS SIGNED COPY IS RETURNED.



5649 North 5000 East, Bourbonnais, IL 60914 Phone 815-474-5875 Fax 815-468-8595 Email: office@xtremefireprotection.com

This Proposal and Contract ("Agreement") is between Xtreme Fire Protection, Inc., ("XFP" or Company") and Jerry Kulhanek ("Customer"). XFP hereby agrees to perform the Work described in the Scope of Work in Section I for an in consideration of the payment of the prices set forth herein, subject to the terms and conditions of this Agreement.

Page 1 of 3

March 26, 2014

To: Jerry Kulhanek
507 Taclott LLC
PO Box 112
Lemont IL 60439

Re: Pollyanna Brewing Company
431 Talcott Ave
Lemont IL 60439

Contract #: X 214-447

Attention: Jerry Kulhanek :

We propose to perform the following fire protection work at the above location for the sum of \$24,840.00. Breakdown as follows:

I-PROVIDE AND INSTALL THE FOLLOW FOR A WET FIRE SPRINKLER SYSYTEM:

- A. Prepare and submit drawings based on drawing numbers A-1 and A-2 provided by Jerry Kulhanek dated 1/1/14 . ✓
- B. Provide and install all steel pipe, hangers, heads, and necessary material needed to complete job.
- C. Change up to 55 uprights to chrome pendants as needed (basement only)
- D. Add up to 25 upright heads as needed around wood framing (basement only)
- E. Add high temperature heads above boiler
- F. Add head w/ tampered valve in elevator shaft
- G. Add hangers as needed on existing pipe (basement only)
- H. Re-hang 2 lines that were removed for elevator construction
- I. Re-connect system to riser
- J. Hydraulic calculations
- K. Hydrostatic test (basement only)

II- WORK HOURS:

XFP works Monday-Friday 7:00am-3:30pm. Any night work (after 3:30pm) performed will increase our labor rate as noted above.

III-APPROVALS:

XFP will obtain approvals from Lemont Fire Prevention Bureau.

IV-MATERIAL/EQUIPMENT SPECIFICATIONS:

All material and equipment used for the installation of the fire prevention system shall be selected by XFP and be U.L. listed.

V- STARTING POINT:

XFP starts its work at 3" feed main in basement.

Initials

VI-EXCLUSIONS TO THIS CONTRACT:

- A. Underground piping/excavation
- B. Alarm panel or smoke detectors
- C. Electrical wiring of bells
- D. Plan review fees/ permits or fees
- E. Testing/adjusting of backflow
- F. Fire pump
- G. Cutting holes in drywall, acoustical ceiling to accommodate fire sprinklers
- H. Moving of any items in way of installation of fire sprinklers
- I. Boxing or soffeting in of pipe
- J. Mounting of bells
- K. Concealed type heads
- L. Removal of ceiling tiles or grid
- M. Jockey pump
- N. Bond
- O. Flow test
- P. Fire Extinguishers
- Q. Painting of pipe
- R. Dry pipe valve
- S. Concrete Coring
- T. Fire Caulking
- U. Man Lifts
- V. Umbrella Insurance

VII- DISCLAIMERS

- A. Jobsite to be asbestos free
- B. Jobsite to be free of lead paint
- C. This is a set price not based on time and material, upon completion of project we will not be re-negotiating price. Once contract is signed drawings will be started immediately if at any time the project is held up or cancelled after signed contract XFP will invoice for work performed to date.
- D. Any changes in field will be looked at as a change order and will need approval prior to proceeding with work.
- E. XFP will provide a one year warranty on labor and material for date of hydrostatic test.
- F. All material removed becomes property of Xtreme Fire Protection, Inc.
- G. This proposal is based on two mobilizations for our fitters. Any more than two mobilizations will be an extra charge and require a signed change order.

VIII-TEST:

XFP will hydrostatically test these systems as defined in N.F.P.A. # 13, 200 lbs., for (2) hours. At no time will XFP or its employees be responsible for any merchandise, equipment, material, contents, or people in the building at time of test. XFP will not be responsible for any existing pipe/fittings or sprinkler heads that leak at time of testing. Included in this contract is one hydrostatic test, if there are leaks on existing piping and second hydrostatic test is required it will be an additional \$600 per test.

IX-TERMS OF ACCEPTANCE:

Due upon acceptance	\$ 4,800.00
Due upon material delivery	\$ 11,140.00
Due upon mains & lines installed	\$ 7,900.00
Due upon final testing	\$ 1,000.00

This proposal may be withdrawn by us if not accepted within 60 days. We reserve the right to adjust price to meet current labor and material costs after 60 days.

Thank you for the opportunity to serve, and promise our dedication and best workmanship on this project

 Initials

X-TERMS AND CONDITIONS:

- A. **Price.** The price for work to be performed under this agreement on a time and material basis shall be based upon the prevailing XFP prices for material, labor and related items, in effect at the time supplied under this agreement. Further in the event that this agreement is executed on a "price not to exceed" basis, the price the customer shall be lesser of: 1) the limit price quoted, or 2) the actual cumulative billing based on the aforementioned prevailing prices. Any change in the Scope of Work may require an increase in the price. XFP may raise the price in event of a change in regulations or other change in conditions or requirements that materially change the Scope of Work including sudden extraordinary raises in costs, including materials and labor costs.
- B. **Payment Terms.** Customer shall pay XFP as specified in section 9 above, but in no event later than thirty (30) days from the date of the invoice(s) for the Work. Customer shall pay a late fee of one and one half percent (1 ½%) per month for any past due invoices. If more than one invoice is issued, the Payment Terms apply to each invoice. If XFP is subsequently requested by the Customer to perform additional work beyond the Work set out in the above scope of work, the Payment Terms shall apply equally to the additional work. Customer shall pay all taxes, permits and other charges, including but not limited to state and local sales and excise taxes, however designated, levied or based on the service charges pursuant to this Agreement. Where the Agreement is not executed, payment shall constitute acceptance of all the terms and conditions of the Agreement.
- C. **Additional Work.** Additional work performed for the Customer by XFP (beyond the work set out in the above scope of work section) will be included in subsequent invoices and shall be governed by and subject to all of their terms and conditions of this Agreement.
- D. **Amendment/ Modifications:** The terms of Customer's purchase order shall not serve to modify this Agreement. This Agreement may be modified or amended only by a written instrument signed by duly authorized representative of each party, specifically referring to this Agreement. No term of any amendment shall be implied to change any limitation on liability or indemnity provision of this Agreement.
- E. **Liability Limitation/ Indemnity.** Customer agrees the XFP's liability for property damage, personal injury, or death, whether arising in contract, tort, strict liability or otherwise, shall not exceed the agreement price set out above (as increased by the price for any additional work) or, where the time and material term is selected above, customer's time and materials payments to XFP. Customer further agrees that XFP shall not be liable for any special, indirect, incidental or consequential damages or any economic loss damages of any kind and that Customer shall indemnify and hold XFP harmless from any and all third party claims relating to the Customer's negligence or misconduct, including Customer's failure to maintain the systems or keep the system in operative condition or relating to XFP's performance or failure to perform under this agreement.
- F. **Equipment On Site.** Where XFP may leave/ store materials or equipment on site for convenience of performing the Work, Customer hereby grants XFP a security interest in the materials and equipment, which may include pipes, clamps, sprinkler heads, other materials, and generators, power tools, hand tools, or other tools and equipment, and Customer authorizes XFP to file a financing statement or other documents in connection therewith in order for XFP to perfect its security interest. Customer shall provide appropriate safe and secure storage for such materials and equipment and shall not interfere with XFP's markings designed to show ownership on such materials and/or equipment.
- G. **Mechanics Liens.** Customer acknowledges that XFP shall acquire a Mechanics Lien on the premises of the project and Customer shall cooperate in good faith with XFP. Upon request, Customer shall provide XFP with the project's common address, the property identification number (PIN), the project owner's identity, any information regarding lenders on the premises, and any other reasonable or legally required information requested by XFP for the purpose of perfecting a mechanics lien.
- H. **Solicitation.** Customer shall not engage in any direct or indirect solicitation of any XFP employee (attempting to influence the XFP employee to leave XFP's employment) during the time of the performance of the Agreement and for a period of two years thereafter.
- I. **Audit Right.** Should Customer be in default of its payment obligations, Customer shall provide XFP or its representative access to all of Customer's financial records, including, but not limited to, its Income Statement, Balance Sheet and General Ledger so that XFP can verify Customer's financial positions and make prompt appropriate decisions.
- J. **Injunctive Relief.** Customer agrees that the nature of any breach of the provisions in sections G, H, and I relating to mechanics liens, solicitation, and audit right is difficult to measure and agrees that injunctive relief is appropriate. Customer shall pay XFP's costs and attorney's fees should XFP prevail in an action pursuant to paragraphs G and or H relating to mechanics liens and solicitation.
- K. **Working Conditions.** Customer shall provide a safe working environment for XFP to perform the Work free from debris and hazards, including compliance with all federal, state, and local regulations, including, but not limited to OSHA regulations. Customer shall provide utilities necessary to perform the Work.
- L. **Termination.** XFP may cease performance and/ or terminate this Agreement upon: 1) Customer's failure to perform or meet any material obligation under this Agreement, including failing to pay as agreed, and/ or 2) Customer becoming insolvent or filing for bankruptcy or similar proceeding. XFP may charge Customer a termination fee equal to its costs plus 15% of the contract price should Customer cancel the contract after XFP has incurred costs in preparing to perform including but not limited to ordering materials and contracting labor.
- M. **Force Majeure.** XFP shall not be liable for any delay or failure to perform to the extent such is due, in whole or in part, to any occurrence(s) beyond XFP's reasonable control, including, but not limited to: acts of God; compliance with any order or request of any governmental authority; act of war, rebellion, or sabotage; fire; flood; release of hazardous toxic substances; explosions; accidents; riots; strikes or other concerted acts of workmen.
- N. **Intellectual Property/ Employee/ Subcontractors.** Customer acknowledges that XFP's employees or subcontractors are not employees of Customer. Customer acknowledges that it has no legal interest in, and that XFP maintains all ownership rights in, technical information, inventions, discoveries and improvements, patentable or un-patentable, and any copyrightable material conceived by XFP's employees, independent contractors, or subcontractors.
- O. **Use of Customer Name.** Customer hereby authorized XFP to use Customer's name in any reasonable manner, including in writing in paper or electronic form (web-based) to advertise XFP's services and accomplishments.
- P. **Assignment.** Neither party may assign this Contractor without the other party's written consent.
- Q. **Entire Agreement/ Counterparts.** This Agreement constitutes the entire agreement between the parties with respect to the subject matter hereof and supersedes any and all prior agreements or understandings with respect thereto. Customer acknowledges that it has read this agreement, understands it, and agrees to be bound by its terms and conditions. Neither party shall be bound by any statements or representation not contained in the Agreement. This Agreement may be executed in counterparts.
- R. **Governing Law/ Venue/ Mediation.** This agreement shall be governed by the laws of the state of Illinois. Any dispute arising from the subject matter of this Agreement shall be submitted to mediation. Each party shall submit to the other a list of three proposed available mediators. Each party shall strike a name from the combined list of mediators, with XFP starting. The last mediator remaining on the list shall mediate the dispute. If the dispute is not resolved in mediation after both sides have acted in good-faith, then the dispute may be taken to court. Any legal action to enforce any rights shall be brought in the Circuit Court of Kankakee County, Illinois.

Jerry Kulhanek – 507 Talcott LLC

Xtreme Fire Protection, Inc.

BY: _____

BY: _____

Name: _____

NAME: _____

TITLE: _____

TITLE: _____

DATE: _____

DATE: _____

to: Mayor Brian K. Reaves
Village Board of Trustees

from: James L. Cainkar, P.E., P.L.S., Acting Village Engineer

subject: **Warner Avenue Water Main Replacement - Phase I
South of Weimer Avenue to Peiffer Avenue**

date: April 16, 2014

BACKGROUND/HISTORY

Twelve (12) bids were received on April 15, 2014 @ 10:00 am for the Warner Avenue Water Main Replacement – Phase I project (South of Weimer Avenue to Peiffer Avenue), which work consists of the replacement of an existing 4-inch water main with a new 8-inch water main in trench; hydrants; water service reconnections; and all appurtenant construction. The low bidder was Riccio Construction Company, which bid was in the amount of \$227,770.00. The bid was \$61,600.00 (21.29%) below the Engineer's Estimate of \$289,370.00.

RECOMMENDATION

Award of the Warner Avenue Water Main Replacement – Phase I project to Riccio Construction Company based on their bid amount \$227,770.00, will allow the project to proceed on schedule.

ATTACHMENTS

- Resolution Authorizing Award of Contract
- Letter of Award Recommendation; and
- Bid Tabulation listing the bid received, including company name, address and amount of bid.

VILLAGE BOARD ACTION REQUIRED

Approval of Resolution awarding the contract to Riccio Construction Company.

RESOLUTION

RESOLUTION AUTHORIZING AWARD OF CONTRACT

**Warner Avenue Water Main Replacement - Phase I
South of Weimer Avenue to Peiffer Avenue**

WHEREAS, the Village of Lemont requires that the Warner Avenue Water Main Replacement – Phase I project be completed; and

WHEREAS, the Village seeks to utilize the construction firm of Riccio Construction Company for such work; and

WHEREAS, Riccio Construction Company submitted a low bid for such work in the amount of \$227,770.00.

NOW, THEREFORE, BE IT RESOLVED, by the President and Board of Trustees that the Contract with Riccio Construction Company is hereby approved.

PASSED AND APPROVED BY THE PRESIDENT AND BOARD OF TRUSTEES OF THE VILLAGE OF LEMONT, COUNTIES OF COOK, WILL AND DuPAGE, ILLINOIS, on this 12th day of May, 2014.

AYES

NAYS

PASSED

ABSENT

Debby Blatzer
Paul Chialdikas
Clifford Miklos
Rick Sniegowski
Ronald Stapleton
Jeanette Virgilio

CHARLENE SMOLLEN, Village Clerk

Approved by me this 12th day of May, 2014.

A t t e s t:

BRIAN K. REAVES, Village President

CHARLENE SMOLLEN, Village Clerk



Frank Novotny & Associates, Inc.

825 Midway Drive ♦ Willowbrook, IL ♦ 60527 ♦ Telephone: (630) 887-8640 ♦ Fax: (630) 887-0132

Civil Engineers/
Municipal Consultants

Mr. George Schafer
Administrator
Village of Lemont
418 Main Street
Lemont, Illinois 60439

April 16, 2014

Re: **Warner Avenue Water Main Replacement – Phase I**
South of Weimer Avenue to Peiffer Avenue
Bid Opening: April 15, 2014 at 10:00 am

Dear George:

Listed below and on the attached "Bid Tabulation", please find the results of the April 15, 2014 bid opening for the above-captioned project. Twelve (12) bids were received and tabulated, with errors being found that did not affect the bid order. A summary is as follows:

Riccio Construction	\$ 227,770.00
Suburban General Construction.....	247,770.00
J. Congdon Sewer Services, Inc.	277,387.50
City Construction Company.....	285,102.00
Stip Brothers Excavating.....	285,471.00
Superior Excavating.....	290,673.39
Unique Plumbing Company.....	306,819.40
Len Cox & Sons Excavating.....	311,115.00
Vian Construction Company.....	326,228.00
Conley Excavating.....	330,381.00
P.T. Ferro Construction.....	331,248.00
Gerardi Sewer & Water.....	592,951.00
Engineer's Estimate.....	\$ 289,370.00

The low bid submitted by Riccio Construction, in the amount of \$227,770.00, is \$61,600.00 (21.29%) below the Engineer's Estimate of \$289,370. Since Riccio Construction is qualified to perform this type of work, we therefore recommend that the Contract be awarded to **Riccio Construction, P.O. Box 672, Palos Park, IL 60464**, in the amount of **\$227,770.00**.

Should you have any questions concerning this matter, please do not hesitate to contact me.

Very truly yours,

FRANK NOVOTNY & ASSOCIATES, INC.

James L. Cainkar, P.E., P.L.S.

JLC/dn

Enclosure

cc: Mr. Ralph Pukula, Director of Public Works, w/Enc.
Ms. Linda Molitor, Executive Assistant, w/Enc.
File No. 13337

OWNER: Village of Lemont
PROJECT DESCRIPTION: Warner Avenue Water Main Replacement - Phase I
 South of Weimer Avenue to Peiffer Avenue
BID OPENING: April 15, 2014 at 10:00 am

PROJECT NO : 13337

Item No	Description	Unit	Quantity	Engineers Estimate		Riccio Construction P.O. Box 672 Palos Park, IL 60464 5% Bid Bond		Suburban General Constr. 1019 East 31st Street LaGrange Park, IL 60526 5% Bid Bond		J. Congdon Sewer Serv. 170-A Alexandra Way Carol Stream, IL 60188 5% Bid Bond		City Construction Company 4403 W Lawrence Ave, #205 Chicago, IL 60630 5% Bid Bond		Stip Brothers Excavating 19042 W Manhattan Road Elwood, IL 60421 5% Bid Bond		Superior Excavating P.O. Box 575 Channahon, IL 60410 5% Bid Bond	
				Unit Price	Amount	Unit Price	Amount	Unit Price	Amount	Unit Price	Amount	Unit Price	Amount	Unit Price	Amount	Unit Price	Amount
1	Water Main in Trench, Ductile Iron, 8"	FOOT	739	70.00	51,730.00	57.00	42,123.00	81.00	59,859.00	80.00	59,120.00	70.00	51,730.00	58.00	42,862.00	74.00	54,686.00
2	Water Main in Trench, PVC (C-900), 8"	FOOT	270	70.00	18,900.00	46.00	12,420.00	88.00	18,360.00	70.00	18,900.00	58.00	15,660.00	55.00	14,850.00	48.00	12,960.00
3	Encasing Pipe, PVC (C-900), 12"	FOOT	360	80.00	28,800.00	30.00	10,800.00	1.00	360.00	30.00	10,800.00	120.00	43,200.00	33.00	11,880.00	41.00	14,760.00
4	Pressure Connection, 8" x 8"	EACH	2	4,500.00	9,000.00	3,850.00	7,700.00	1,700.00	3,400.00	4,500.00	9,000.00	3,323.00	6,646.00	2,565.00	5,130.00	4,100.00	8,200.00
5	Pressure Connection, 6" x 6"	EACH	1	4,000.00	4,000.00	2,900.00	2,900.00	1,200.00	1,200.00	3,500.00	3,500.00	3,323.00	3,323.00	1,960.00	1,960.00	3,425.00	3,425.00
6	Valve Vault, Type A, 5' Dia., Type 1 Frame, Closed Lid	EACH	3	4,000.00	12,000.00	2,100.00	6,300.00	1,250.00	3,750.00	1,000.00	3,000.00	4,115.00	12,345.00	3,190.00	9,570.00	1,160.00	3,480.00
7	Polyethylene Encasement	FOOT	739	2.00	1,478.00	2.00	1,478.00	1.00	739.00	1.00	739.00	1.00	739.00	1.00	739.00	0.01	7.39
8	Disconnect & Cap Existing Water Main, 8"	EACH	1	1,000.00	1,000.00	1,575.00	1,575.00	3,500.00	3,500.00	1,800.00	1,800.00	1,500.00	1,500.00	3,780.00	3,780.00	850.00	850.00
9	Disconnect & Cap Existing Water Main, 6"	EACH	2	1,000.00	2,000.00	1,475.00	2,950.00	3,500.00	7,000.00	1,500.00	3,000.00	1,500.00	3,000.00	2,100.00	4,200.00	811.00	1,622.00
10	Fire Hydrants	EACH	4	4,000.00	16,000.00	4,550.00	18,200.00	9,750.00	39,000.00	4,500.00	18,000.00	4,410.00	17,640.00	3,990.00	15,960.00	4,450.00	17,800.00
11	Connection to Existing Water Main, 6"	EACH	1	2,300.00	2,300.00	2,100.00	2,100.00	3,500.00	3,500.00	2,300.00	2,300.00	1,500.00	1,500.00	1,200.00	1,200.00	2,100.00	2,100.00
12	Remove Existing Fire Hydrants	EACH	2	800.00	1,600.00	400.00	800.00	125.00	250.00	500.00	1,000.00	525.00	1,050.00	250.00	500.00	600.00	1,200.00
13	Fire Hydrant Extensions	VERT F	2	300.00	600.00	215.00	430.00	450.00	900.00	400.00	800.00	775.00	1,550.00	946.00	1,892.00	817.00	1,634.00
14	Pipe Fittings (Mechanical Joints), Ductile Iron	POUND	1400	4.00	5,600.00	4.00	5,600.00	0.25	350.00	5.00	7,000.00	8.00	11,200.00	6.50	9,100.00	10.00	14,000.00
15	Selected Granular Backfill (CA-6)	CU YD	1150	36.00	41,400.00	24.00	27,600.00	10.00	11,500.00	28.00	32,200.00	23.00	26,450.00	41.00	47,150.00	1.00	1,150.00
16	Water Service Reconnection, 1-1/2", with New Buffalo Box	EACH	17	1,200.00	20,400.00	1,450.00	24,650.00	2,000.00	34,000.00	1,500.00	25,500.00	1,000.00	17,000.00	1,420.00	24,140.00	5,000.00	85,000.00
17	Water Service Line, 1-1/2"	FOOT	424	25.00	10,600.00	24.00	10,176.00	10.00	4,240.00	15.00	6,360.00	16.00	6,784.00	27.00	11,448.00	75.00	31,800.00
18	Nitrile Gaskets, 8"	EACH	5	200.00	1,000.00	100.00	500.00	200.00	1,000.00	285.00	1,425.00	32.00	160.00	176.00	880.00	185.00	925.00
19	Adjusting Sanitary Sewers, (PVC/SDR 18), 8" Dia. or Less	FOOT	100	40.00	4,000.00	14.00	1,400.00	5.00	500.00	15.00	1,500.00	55.00	5,500.00	55.00	5,500.00	50.00	5,000.00
20	Non-Shear Mission Couplings, 6"	EACH	10	150.00	1,500.00	40.00	400.00	50.00	500.00	50.00	500.00	130.00	1,300.00	44.00	440.00	50.00	500.00
21	Encasing Pipe, PVC (Schedule 40), 4"	FOOT	300	20.00	6,000.00	9.00	2,700.00	2.00	600.00	5.00	1,500.00	20.00	6,000.00	7.00	2,100.00	17.00	5,100.00
22	Filling Existing Valve Box	EACH	2	300.00	600.00	75.00	150.00	125.00	250.00	100.00	200.00	1,235.00	2,470.00	150.00	300.00	100.00	200.00
23	Class D Patches, Type III, 4"	SQ YD	75	50.00	3,750.00	47.00	3,525.00	32.00	2,400.00	55.00	4,125.00	45.00	3,375.00	51.00	3,825.00	1.00	75.00
24	Class D Patches, Type IV, 4"	SQ YD	560	40.00	22,400.00	45.00	25,200.00	32.00	17,920.00	53.00	29,680.00	41.00	22,960.00	51.00	28,560.00	1.00	560.00
25	Sidewalk Removal	SQ FT	75	2.00	150.00	3.00	225.00	1.00	75.00	1.00	75.00	2.00	150.00	5.00	375.00	2.00	150.00
26	Concrete Driveway Pavement Removal	SQ YD	20	12.00	240.00	10.00	200.00	5.00	100.00	10.00	200.00	15.00	300.00	45.00	900.00	10.00	200.00
27	Portland Cement Concrete Driveway Pavement, 7"	SQ YD	20	89.00	1,600.00	50.00	1,000.00	42.00	840.00	63.00	1,260.00	50.00	1,000.00	85.00	1,700.00	52.00	1,040.00
28	Portland Cement Concrete Sidewalk, 5"	SQ FT	75	8.00	600.00	6.00	450.00	7.00	525.00	6.50	487.50	10.00	750.00	8.00	600.00	7.00	525.00
29	Driveway Pavement Removal	SQ YD	55	8.00	440.00	10.00	550.00	5.00	275.00	10.00	550.00	10.00	550.00	28.00	1,540.00	10.00	550.00
30	Combination Curb & Gutter Removal	FOOT	102	6.00	612.00	4.00	408.00	1.00	102.00	5.00	510.00	10.00	1,020.00	10.00	1,020.00	10.00	1,020.00
31	Combination Concrete Curb & Gutter, Type B-6.12	FOOT	102	35.00	3,570.00	30.00	3,060.00	20.00	2,040.00	28.00	2,856.00	25.00	2,550.00	60.00	6,120.00	27.00	2,754.00
32	Incidental Hot-Mix Asphalt Surfacing (for Driveways), 3"	TON	10	150.00	1,500.00	190.00	1,900.00	150.00	1,500.00	150.00	1,500.00	160.00	1,600.00	150.00	1,500.00	100.00	1,000.00
33	Exploratory Excavation	CU YD	50	40.00	2,000.00	4.00	200.00	25.00	1,250.00	50.00	2,500.00	50.00	2,500.00	55.00	2,750.00	28.00	1,400.00
34	Restoration	L SUM	1	5,000.00	5,000.00	5,000.00	5,000.00	9,485.00	9,485.00	10,500.00	10,500.00	2,500.00	2,500.00	10,000.00	10,000.00	9,000.00	9,000.00
35	Traffic Control & Protection	L SUM	1	3,000.00	3,000.00	1,600.00	1,600.00	15,000.00	15,000.00	14,000.00	14,000.00	5,100.00	5,100.00	9,000.00	9,000.00	4,500.00	4,500.00
36	Insurance Provisions - Complete	L SUM	1	4,000.00	4,000.00	1,500.00	1,500.00	1,500.00	1,500.00	1,000.00	1,000.00	4,000.00	4,000.00	2,000.00	2,000.00	1,500.00	1,500.00
Totals:					289,370.00		227,770.00		247,770.00		277,387.50		285,102.00		285,471.00		290,673.39
Bid Error Corrections:																	
Corrected Totals ---							227,770.00		247,770.00		277,387.50		285,102.00		285,471.00		290,673.39
Over / Under ----							-61,800.00		-41,600.00		-11,882.50		-4,268.00		-3,999.00		1,303.39
Percent ----							-21.29%		-14.38%		-4.14%		-1.47%		-1.35%		0.45%

OWNER: Village of Lemont
 PROJECT DESCRIPTION: Warner Avenue Water Main Replacement - Phase I
 South of Weimer Avenue to Peiffer Avenue
 BID OPENING: April 15, 2014 at 10:00 am

PROJECT NO: 13337

Item No	Description	Unit	Quantity	Engineers Estimate		Unique Plumbing Co. 9408 W 47th Street Brookfield, IL 60513 5% Bid Bond		Len Cox & Sons Excavating 1203 Theodore Street Crest Hill, IL 60403 5% Bid Bond		Vian Construction Co., Inc. 1041 Martha Street Elk Grove Village, IL 60007 5% Bid Bond		Conley Excavating 1555 Gramercy Place Morris, IL 60450 5% Bid Bond		P.T. Ferro Construction P.O. Box 156 Joliet, IL 60434-0156 5% Bid Bond		Gerardi Sewer & Water 4520 N Osage Norridge, IL 60706 5% Bid Bond	
				Unit Price	Amount	Unit Price	Amount	Unit Price	Amount	Unit Price	Amount	Unit Price	Amount	Unit Price	Amount	Unit Price	Amount
1	Water Main in Trench, Ductile Iron, 8"	FOOT	739	70.00	51,730.00	82.80	61,189.20	60.00	44,340.00	90.00	66,510.00	81.50	60,228.50	70.00	51,730.00	175.00	129,325.00
2	Water Main in Trench, PVC (C-900), 8"	FOOT	270	70.00	18,900.00	76.10	20,547.00	50.00	13,500.00	79.00	21,330.00	69.00	18,630.00	50.00	13,500.00	150.00	40,500.00
3	Encasing Pipe, PVC (C-900), 12"	FOOT	380	80.00	28,800.00	57.00	20,520.00	75.00	27,000.00	28.00	10,080.00	55.00	19,800.00	80.00	28,800.00	60.00	21,600.00
4	Pressure Connection, 8" x 8"	EACH	2	4,500.00	9,000.00	3,865.00	7,730.00	4,000.00	8,000.00	7,750.00	15,500.00	4,000.00	8,000.00	4,500.00	9,000.00	6,750.00	13,500.00
5	Pressure Connection, 6" x 6"	EACH	1	4,000.00	4,000.00	3,300.00	3,300.00	3,400.00	3,400.00	2,700.00	2,700.00	3,750.00	3,750.00	4,000.00	4,000.00	6,000.00	6,000.00
6	Valve Vault, Type A, 5' Dia., Type 1 Frame, Closed Lid	EACH	3	4,000.00	12,000.00	2,500.00	7,500.00	2,000.00	6,000.00	1,700.00	5,100.00	2,500.00	7,500.00	3,000.00	9,000.00	2,500.00	7,500.00
7	Polyethylene Encasement	FOOT	739	2.00	1,478.00	0.80	591.20	1.00	739.00	1.00	739.00	1.00	739.00	2.00	1,478.00	1.50	1,108.50
8	Disconnect & Cap Existing Water Main, 8"	EACH	1	1,000.00	1,000.00	1,800.00	1,800.00	2,200.00	2,200.00	2,400.00	2,400.00	1,000.00	1,000.00	1,700.00	1,700.00	1,675.00	1,675.00
9	Disconnect & Cap Existing Water Main, 6"	EACH	2	1,000.00	2,000.00	1,800.00	3,600.00	2,000.00	4,000.00	2,400.00	4,800.00	900.00	1,800.00	1,600.00	3,200.00	1,275.00	2,550.00
10	Fire Hydrants	EACH	4	4,000.00	16,000.00	4,220.00	16,880.00	3,700.00	14,800.00	3,960.00	15,840.00	4,300.00	17,200.00	5,000.00	20,000.00	6,000.00	24,000.00
11	Connection to Existing Water Main, 6"	EACH	1	2,300.00	2,300.00	2,800.00	2,800.00	1,850.00	1,850.00	4,000.00	4,000.00	2,600.00	2,600.00	2,400.00	2,400.00	5,000.00	5,000.00
12	Remove Existing Fire Hydrants	EACH	2	800.00	1,600.00	300.00	600.00	1,500.00	3,000.00	300.00	600.00	500.00	1,000.00	1,500.00	3,000.00	600.00	1,200.00
13	Fire Hydrant Extensions	VERT F	2	300.00	600.00	7,115.00	14,230.00	1,100.00	2,200.00	480.00	960.00	700.00	1,400.00	750.00	1,500.00	750.00	1,500.00
14	Pipe Fittings (Mechanical Joints), Ductile Iron	POUND	1400	4.00	5,600.00	3.80	5,320.00	7.50	10,500.00	5.00	7,000.00	8.50	11,900.00	3.50	4,900.00	6.00	8,400.00
15	Selected Granular Backfill (CA-6)	CU YD	1150	36.00	41,400.00	16.00	18,400.00	38.00	43,700.00	30.00	34,500.00	28.00	32,200.00	45.00	51,750.00	40.00	46,000.00
16	Water Service Reconnection, 1-1/2", with New Buffalo Box	EACH	17	1,200.00	20,400.00	1,900.00	32,300.00	1,750.00	29,750.00	1,900.00	32,300.00	1,400.00	23,800.00	1,750.00	29,750.00	2,575.00	43,775.00
17	Water Service Line, 1-1/2"	FOOT	424	25.00	10,600.00	40.00	16,960.00	46.00	19,504.00	62.00	26,288.00	36.00	15,264.00	30.00	12,720.00	30.00	12,720.00
18	Nitrile Gaskets, 8"	EACH	5	200.00	1,000.00	35.00	175.00	75.00	375.00	130.00	650.00	225.00	1,125.00	380.00	1,900.00	100.00	500.00
19	Adjusting Sanitary Sewers, (PVC/SDR 18), 8" Dia. or Less	FOOT	100	40.00	4,000.00	40.00	4,000.00	72.00	7,200.00	75.00	7,500.00	63.00	6,300.00	100.00	10,000.00	30.00	3,000.00
20	Non-Shear Mission Couplings, 6"	EACH	10	150.00	1,500.00	60.00	600.00	300.00	3,000.00	70.00	700.00	150.00	1,500.00	300.00	3,000.00	35.00	350.00
21	Encasing Pipe, PVC (Schedule 40), 4"	FOOT	300	20.00	6,000.00	35.00	10,500.00	35.00	10,500.00	7.00	2,100.00	25.00	7,500.00	55.00	16,500.00	25.00	7,500.00
22	Filling Existing Valve Box	EACH	2	300.00	600.00	50.00	100.00	255.00	510.00	300.00	600.00	250.00	500.00	150.00	300.00	150.00	300.00
23	Class D Patches, Type III, 4"	SQ YD	75	50.00	3,750.00	46.00	3,450.00	74.00	5,550.00	61.00	4,575.00	60.00	4,500.00	40.00	3,000.00	60.00	4,500.00
24	Class D Patches, Type IV, 4"	SQ YD	560	40.00	22,400.00	46.00	25,760.00	48.00	26,880.00	61.00	34,160.00	54.00	30,240.00	32.50	18,200.00	60.00	33,600.00
25	Sidewalk Removal	SQ FT	75	2.00	150.00	3.00	225.00	5.00	375.00	1.00	75.00	3.00	225.00	2.50	187.50	1.50	112.50
26	Concrete Driveway Pavement Removal	SQ YD	20	12.00	240.00	115.00	300.00	8.00	160.00	14.00	280.00	9.00	180.00	10.00	200.00	12.00	240.00
27	Portland Cement Concrete Driveway Pavement, 7"	SQ YD	20	80.00	1,600.00	65.00	1,300.00	75.00	1,500.00	63.00	1,260.00	59.00	1,180.00	80.00	1,600.00	100.00	2,000.00
28	Portland Cement Concrete Sidewalk, 5"	SQ FT	75	8.00	600.00	7.00	525.00	11.00	825.00	5.00	375.00	7.50	562.50	7.50	562.50	12.00	900.00
29	Driveway Pavement Removal	SQ YD	55	8.00	440.00	15.00	825.00	5.00	275.00	10.00	550.00	5.00	275.00	10.00	550.00	5.00	275.00
30	Combination Curb & Gutter Removal	FOOT	102	6.00	612.00	6.00	612.00	8.00	816.00	8.00	816.00	8.00	816.00	5.00	510.00	5.00	510.00
31	Combination Concrete Curb & Gutter, Type B-6.12	FOOT	102	35.00	3,570.00	40.00	4,080.00	45.00	4,590.00	20.00	2,040.00	58.00	5,916.00	30.00	3,060.00	30.00	3,060.00
32	Incidental Hot-Mix Asphalt Surfacing (for Driveways), 3"	TON	10	150.00	1,500.00	130.00	1,300.00	300.00	3,000.00	240.00	2,400.00	150.00	1,500.00	150.00	1,500.00	225.00	2,250.00
33	Exploratory Excavation	CU YD	50	40.00	2,000.00	5.00	250.00	42.00	2,100.00	46.00	2,300.00	25.00	1,250.00	75.00	3,750.00	50.00	2,500.00
34	Restoration	L SUM	1	5,000.00	5,000.00	10,300.00	10,300.00	5,000.00	5,000.00	4,400.00	4,400.00	15,000.00	15,000.00	10,000.00	10,000.00	50,000.00	50,000.00
35	Traffic Control & Protection	L SUM	1	3,000.00	3,000.00	3,000.00	3,500.00	3,150.00	3,150.00	8,000.00	8,000.00	20,000.00	20,000.00	4,500.00	4,500.00	100,000.00	100,000.00
36	Insurance Provisions - Complete	L SUM	1	4,000.00	4,000.00	2,750.00	2,750.00	826.00	826.00	2,800.00	2,800.00	5,000.00	5,000.00	3,500.00	3,500.00	15,000.00	15,000.00
Totals:					289,370.00		292,019.40		311,115.00		326,228.00		330,380.50		331,248.00		592,951.00
Bid Error Corrections:																	
13	Fire Hydrant Extensions						14,230.00										
26	Concrete Driveway Pavement Removal						2,300.00										
Total							306,819.40						330,381.00				
Corrected Totals							306,819.40		311,115.00		326,228.00		330,381.00		331,248.00		592,951.00
Over / Under							17,449.40		21,745.00		36,858.00		41,011.00		41,878.00		303,581.00
Percent							6.03%		7.51%		12.74%		14.17%		14.47%		104.91%

to: Mayor Brian K. Reaves
Village Board of Trustees

from: James L. Cainkar, P.E., P.L.S., Acting Village Engineer

subject: Warner Avenue Water Main Replacement - Phase 2
Peiffer Avenue to Norton Avenue

date: April 16, 2014

BACKGROUND/HISTORY

Eight (8) bids were received on April 17, 2014 @ 10:00 am for the Warner Avenue Water Main Replacement – Phase 2 project (Peiffer Avenue to Norton Avenue), which work consists of the replacement of an existing 6-inch water main with a new 8-inch water main in trench; hydrants; water service reconnections; and all appurtenant construction. The low bidder was Riccio Construction Company, which bid was in the amount of \$202,000.00. The bid was \$23,852.00 (10.56%) below the Engineer's Estimate of \$225,852.00.

RECOMMENDATION

Award of the Warner Avenue Water Main Replacement – Phase 2 project to Riccio Construction Company based on their bid amount \$202,000.00, will allow the project to proceed on schedule.

ATTACHMENTS

- Resolution Authorizing Award of Contract
- Letter of Award Recommendation; and
- Bid Tabulation listing the bid received, including company name, address and amount of bid.

VILLAGE BOARD ACTION REQUIRED

Approval of Resolution awarding the contract to Riccio Construction Company.

RESOLUTION

RESOLUTION AUTHORIZING AWARD OF CONTRACT

**Warner Avenue Water Main Replacement - Phase 2
Peiffer Avenue to Norton Avenue**

WHEREAS, the Village of Lemont requires that the Warner Avenue Water Main Replacement – Phase 2 project be completed; and

WHEREAS, the Village seeks to utilize the construction firm of Riccio Construction Company for such work; and

WHEREAS, Riccio Construction Company submitted a low bid for such work in the amount of \$202,000.00.

NOW, THEREFORE, BE IT RESOLVED, by the President and Board of Trustees that the Contract with Riccio Construction Company is hereby approved.

PASSED AND APPROVED BY THE PRESIDENT AND BOARD OF TRUSTEES OF THE VILLAGE OF LEMONT, COUNTIES OF COOK, WILL AND DuPAGE, ILLINOIS, on this 12th day of May, 2014.

AYES

NAYS

PASSED

ABSENT

Debby Blatzer
Paul Chialdikas
Clifford Miklos
Rick Sniegowski
Ronald Stapleton
Jeanette Virgilio

CHARLENE SMOLLEN, Village Clerk

Approved by me this 12th day of May, 2014.

Attest:

BRIAN K. REAVES, Village President

CHARLENE SMOLLEN, Village Clerk



Frank Novotny & Associates, Inc.

825 Midway Drive ♦ Willowbrook, IL ♦ 60527 ♦ Telephone: (630) 887-8640 ♦ Fax: (630) 887-0132

Civil Engineers/
Municipal Consultants

Mr. George Schafer
Administrator
Village of Lemont
418 Main Street
Lemont, Illinois 60439

April 18, 2014

Re: **Warner Avenue Water Main Replacement – Phase 2:
Peiffer Avenue to Norton Avenue
Bid Opening: April 17, 2014 at 10:00 am**

Dear George:

Listed below and on the attached "Bid Tabulation", please find the results of the April 17, 2014 bid opening for the above-captioned project. Eight (8) bids were received and tabulated, with errors being found in one bid that did affect the bid order. A summary is as follows:

Riccio Construction	\$ 202,000.00
Len Cox & Sons Excavating.....	213,561.00
Unique Plumbing Company.....	214,998.00
City Construction Company.....	219,647.00
Stip Brothers Excavating.....	224,981.00
Suburban General Construction.....	237,669.00
Vian Construction Company.....	254,262.00
Lifco Contractors, Inc.	280,330.00
Engineer's Estimate.....	\$ 225,852.00

The low bid submitted by Riccio Construction, in the amount of \$202,000.00, is \$23,852.00 (10.56%) below the Engineer's Estimate of \$225,852.00. Since Riccio Construction is qualified to perform this type of work, we therefore recommend that the Contract be awarded to **Riccio Construction, P.O. Box 672, Palos Park, IL 60464**, in the amount of **\$202,000.00**.

Should you have any questions concerning this matter, please do not hesitate to contact me.

Very truly yours,

FRANK NOVOTNY & ASSOCIATES, INC.

James L. Cainkar, P.E., P.L.S.

JLC/dn
Enclosure

cc: Mr. Ralph Pukula, Director of Public Works, w/Enc.
Ms. Linda Molitor, Executive Assistant, w/Enc.
File No. 13391

OWNER: Village of Lemont
PROJECT DESCRIPTION: Warner Avenue Water Main Replacement - Phase 2
 Peiffer Avenue to Norton Avenue
BID OPENING: April 17, 2014 at 10:00 am

PROJECT NO : 13391

Item No	Description	Unit	Quantity	Engineers Estimate		Riccio Construction P.O. Box 672 Palos Park, IL 60464 5% Bid Bond		Len Cox & Sons Excavating 1203 Theodore Street Crest Hill, IL 60403 5% Bid Bond		Unique Plumbing Co. 9408 W 47th Street Brookfield, IL 60513 5% Bid Bond		City Construction Company 4403 W Lawrence Ave, #205 Chicago, IL 60630 5% Bid Bond	
				Unit Price	Amount	Unit Price	Amount	Unit Price	Amount	Unit Price	Amount	Unit Price	Amount
1	Exploratory Excavation	CU YD	50	50.00	2,500.00	3.00	150.00	20.00	1,000.00	40.00	2,000.00	50.00	2,500.00
2	Water Main in Trench, Ductile Iron, 8"	FOOT	710	65.00	46,150.00	59.00	41,890.00	55.00	39,050.00	55.50	39,405.00	65.00	46,150.00
3	Encasing Pipe in Trench, PVC (C-900), 12"	FOOT	126	80.00	10,080.00	35.00	4,410.00	64.00	8,064.00	70.00	8,820.00	110.00	13,860.00
4	Pressure Connection, 6" x 6"	EACH	1	4,000.00	4,000.00	2,750.00	2,750.00	3,200.00	3,200.00	3,470.00	3,470.00	2,500.00	2,500.00
5	Pressure Connection, 8" x 8"	EACH	2	4,500.00	9,000.00	3,800.00	7,600.00	3,700.00	7,400.00	3,875.00	7,750.00	2,500.00	5,000.00
6	Gate Valves, 8"	EACH	2	1,500.00	3,000.00	2,300.00	4,600.00	1,700.00	3,400.00	1,600.00	3,200.00	1,460.00	2,920.00
7	Connection to Existing Water Main, 8"	EACH	1	3,000.00	3,000.00	2,400.00	2,400.00	3,000.00	3,000.00	2,400.00	2,400.00	1,500.00	1,500.00
8	Disconnect and Cap Existing Water Main, 6"	EACH	3	1,500.00	4,500.00	1,400.00	4,200.00	1,750.00	5,250.00	1,800.00	5,400.00	1,500.00	4,500.00
9	Disconnect and Cap Existing Water Main, 8"	EACH	1	1,600.00	1,600.00	1,650.00	1,650.00	1,850.00	1,850.00	1,800.00	1,800.00	1,500.00	1,500.00
10	Valve Vaults, Type A, 5'-Dia., Type 1 Frame, Closed Lid	EACH	3	2,500.00	7,500.00	2,200.00	6,600.00	1,900.00	5,700.00	2,500.00	7,500.00	4,115.00	12,345.00
11	Valve Box, Cast Iron, 6"	EACH	2	500.00	1,000.00	330.00	660.00	275.00	550.00	1,180.00	360.00	500.00	1,000.00
12	Polyethylene Encasement	FOOT	710	2.00	1,420.00	2.00	1,420.00	1.00	710.00	0.60	426.00	0.50	355.00
13	Fire Hydrants	EACH	3	3,500.00	10,500.00	4,475.00	13,425.00	3,325.00	9,975.00	4,100.00	12,300.00	4,410.00	13,230.00
14	Remove Existing Fire Hydrants	EACH	3	450.00	1,350.00	350.00	1,050.00	1,100.00	3,300.00	400.00	1,200.00	525.00	1,575.00
15	Water Service Reconnection, 1- 1/2", Near Side, with New Buffalo Box	EACH	8	1,500.00	12,000.00	1,325.00	10,600.00	1,350.00	10,800.00	1,370.00	10,960.00	1,000.00	8,000.00
16	Water Service Reconnection, 1-1/2", Far Side	EACH	8	800.00	6,400.00	1,450.00	11,600.00	1,550.00	12,400.00	800.00	6,400.00	1,000.00	8,000.00
17	Water Service Line, 1-1/2"	FOOT	240	25.00	6,000.00	25.00	6,000.00	32.00	7,680.00	30.00	7,200.00	16.00	3,840.00
18	Pipe Fittings (Mechanical Joints), Ductile iron	POUND	1500	4.00	6,000.00	4.00	6,000.00	7.00	10,500.00	4.80	7,200.00	4.00	6,000.00
19	Remove Existing Valve Box	EACH	2	200.00	400.00	75.00	150.00	250.00	500.00	100.00	200.00	500.00	1,000.00
20	Selected Granular Backfill (CA-6)	CU YD	600	35.00	21,600.00	24.00	14,400.00	37.00	22,200.00	35.00	21,000.00	22.75	13,650.00
21	Storm Sewers, PVC (C-900), Type 2, 12"	FOOT	20	60.00	1,200.00	50.00	1,000.00	62.00	1,240.00	60.00	1,200.00	55.00	1,100.00
22	Storm Sewers, RCCP (O-Ring), Type 2, 18"	FOOT	79	58.00	4,582.00	80.00	6,320.00	67.00	5,293.00	88.00	6,922.00	55.00	4,345.00
23	Adjusting Sanitary Sewers, 8-Inch Diameter or Less	FOOT	80	40.00	3,200.00	14.00	1,120.00	92.00	7,360.00	30.00	2,400.00	55.00	4,400.00
24	Non-Shear Mission Couplings, 6"	EACH	16	150.00	2,400.00	40.00	640.00	75.00	1,200.00	40.00	640.00	130.00	2,080.00
25	Catch Basins, Type A, 4" Dia., Type R-3281-AL Frame and	EACH	1	3,000.00	3,000.00	2,100.00	2,100.00	1,700.00	1,700.00	2,650.00	2,650.00	2,750.00	2,750.00
26	Catch Basins, Type A, 5" Dia., Type R-3281-AL Frame and	EACH	1	4,000.00	4,000.00	3,300.00	3,300.00	1,900.00	1,900.00	3,100.00	3,100.00	3,500.00	3,500.00
27	Manholes, Type A, 5" Dia., Type 1 Frame, and Closed Lid	EACH	1	5,000.00	5,000.00	5,000.00	5,000.00	1,735.00	1,735.00	4,000.00	4,000.00	3,500.00	3,500.00
28	Connection to Existing Catch Basin	EACH	1	1,000.00	1,000.00	700.00	700.00	750.00	750.00	450.00	450.00	1,500.00	1,500.00
29	Disconnect and Plug Existing Storm Sewer, 18"	EACH	4	750.00	3,000.00	300.00	1,200.00	250.00	1,000.00	200.00	800.00	1,500.00	6,000.00
30	Remove Existing Storm Sewer, 18"	FOOT	10	50.00	500.00	25.00	250.00	30.00	300.00	15.00	150.00	50.00	500.00
31	Class D Patches, Type IV, 4"	SQ YD	627	40.00	25,080.00	40.00	25,080.00	37.00	23,199.00	40.00	25,080.00	41.00	25,707.00
32	Combination Curb and Gutter Removal	FOOT	60	5.00	300.00	5.00	300.00	4.00	240.00	6.00	360.00	6.50	390.00
33	Sidewalk Removal	SQ FT	125	3.00	375.00	4.00	500.00	2.00	250.00	1.00	125.00	2.00	250.00
34	Combination Concrete Curb and Gutter, Type M-4.12	FOOT	60	24.00	1,440.00	33.00	1,980.00	45.00	2,700.00	35.00	2,100.00	25.00	1,500.00
35	Portland Cement Concrete Sidewalk, 5 Inch	SQ FT	125	7.00	875.00	7.00	875.00	9.00	1,125.00	8.00	1,000.00	8.00	1,000.00
36	Detectable Warnings	SQ FT	30	30.00	900.00	36.00	1,080.00	33.00	990.00	40.00	1,200.00	20.00	600.00
37	Restoration, Complete	L SUM	1	5,000.00	5,000.00	5,000.00	5,000.00	2,850.00	2,850.00	5,500.00	5,500.00	2,500.00	2,500.00
38	Traffic Control & Protection	L SUM	1	3,000.00	3,000.00	2,500.00	2,500.00	2,400.00	2,400.00	4,500.00	4,500.00	4,000.00	4,000.00
39	Insurance Provision - Complete	L SUM	1	3,000.00	3,000.00	1,500.00	1,500.00	800.00	800.00	1,800.00	1,800.00	4,600.00	4,600.00
Totals :					225,852.00		202,000.00		213,561.00		213,178.00		219,647.00
Bid Error Corrections:													
11	Valve Box, Cast Iron, 6"										2,360.00		
Total											214,998.00		
Corrected Totals ---							202,000.00				214,998.00		219,647.00
Over / Under ----							-23,852.00				-10,854.00		-6,205.00
Percent ----							-10.56%				-4.81%		-2.75%

OWNER: Village of Lemont
 PROJECT DESCRIPTION: Warner Avenue Water Main Replacement - Phase 2
 Peiffer Avenue to Norton Avenue
 BID OPENING: April 17, 2014 at 10:00 am

PROJECT NO : 13391

Item No	Description	Unit	Quantity	Engineers Estimate		Stip Brothers Excavating 19042 W Manhattan Road Elwood, IL 60421 5% Bid Bond		Suburban General Constr. 1019 East 31st Street LaGrange Park, IL 60526 5% Bid Bond		Vian Construction Co., Inc. 1041 Martha Street Elk Grove Village, IL 60007 5% Bid Bond		Lifco Contractors, Inc. P.O. Box 87200 Carol Stream, IL 60188 5% Bid Bond	
				Unit Price	Amount	Unit Price	Amount	Unit Price	Amount	Unit Price	Amount	Unit Price	Amount
1	Exploratory Excavation	CU YD	50	50.00	2,500.00	55.00	2,750.00	10.00	500.00	30.00	1,500.00	45.00	2,250.00
2	Water Main in Trench, Ductile Iron, 8"	FOOT	710	65.00	46,150.00	58.00	41,180.00	73.00	51,830.00	85.00	60,350.00	65.00	46,150.00
3	Encasing Pipe in Trench, PVC (C-900), 12"	FOOT	126	80.00	10,080.00	33.00	4,158.00	10.00	1,260.00	28.00	3,528.00	35.00	4,410.00
4	Pressure Connection, 6" x 6"	EACH	1	4,000.00	4,000.00	1,960.00	1,960.00	3,500.00	3,500.00	3,000.00	3,000.00	6,500.00	6,500.00
5	Pressure Connection, 8" x 8"	EACH	2	4,500.00	9,000.00	2,565.00	5,130.00	4,500.00	9,000.00	3,200.00	6,400.00	7,000.00	14,000.00
6	Gate Valves, 8"	EACH	2	1,500.00	3,000.00	1,300.00	2,600.00	2,500.00	5,000.00	1,460.00	2,920.00	1,300.00	2,600.00
7	Connection to Existing Water Main, 8"	EACH	1	3,000.00	3,000.00	1,500.00	1,500.00	4,000.00	4,000.00	1,500.00	1,500.00	2,800.00	2,800.00
8	Disconnect and Cap Existing Water Main, 6"	EACH	3	1,500.00	4,500.00	2,100.00	6,300.00	2,000.00	6,000.00	1,500.00	4,500.00	1,900.00	5,700.00
9	Disconnect and Cap Existing Water Main, 8"	EACH	1	1,600.00	1,600.00	2,100.00	2,100.00	2,000.00	2,000.00	1,600.00	1,600.00	1,900.00	1,900.00
10	Valve Vaults, Type A, 5'-Dia., Type 1 Frame, Closed Lid	EACH	3	2,500.00	7,500.00	3,190.00	9,570.00	3,500.00	10,500.00	1,400.00	4,200.00	3,100.00	9,300.00
11	Valve Box, Cast Iron, 6"	EACH	2	500.00	1,000.00	600.00	1,200.00	450.00	900.00	200.00	400.00	200.00	400.00
12	Polyethylene Encasement	FOOT	710	2.00	1,420.00	1.00	710.00	1.00	710.00	1.00	710.00	1.00	710.00
13	Fire Hydrants	EACH	3	3,500.00	10,500.00	3,990.00	11,970.00	9,250.00	27,750.00	3,200.00	9,600.00	5,000.00	15,000.00
14	Remove Existing Fire Hydrants	EACH	3	450.00	1,350.00	250.00	750.00	125.00	375.00	300.00	900.00	500.00	1,500.00
15	Water Service Reconnection, 1-1/2", Near Side, with New Buffalo Box	EACH	8	1,500.00	12,000.00	1,420.00	11,360.00	2,000.00	16,000.00	1,700.00	13,600.00	3,300.00	26,400.00
16	Water Service Reconnection, 1-1/2", Far Side	EACH	8	800.00	6,400.00	1,420.00	11,360.00	2,000.00	16,000.00	1,800.00	14,400.00	2,500.00	20,000.00
17	Water Service Line, 1-1/2"	FOOT	240	25.00	6,000.00	27.00	6,480.00	8.00	1,920.00	62.00	14,880.00	45.00	10,800.00
18	Pipe Fittings (Mechanical Joints), Ductile iron	POUND	1500	4.00	6,000.00	2.00	3,000.00	0.25	375.00	5.00	7,500.00	6.00	9,000.00
19	Remove Existing Valve Box	EACH	2	200.00	400.00	150.00	300.00	125.00	250.00	300.00	600.00	100.00	200.00
20	Selected Granular Backfill (CA-6)	CU YD	600	36.00	21,600.00	41.00	24,600.00	13.00	7,800.00	30.00	18,000.00	40.00	24,000.00
21	Storm Sewers, PVC (C-900), Type 2, 12"	FOOT	20	60.00	1,200.00	27.00	540.00	55.00	1,100.00	74.00	1,480.00	55.00	1,100.00
22	Storm Sewers, RCCP (O-Ring), Type 2, 18"	FOOT	79	58.00	4,582.00	33.00	2,607.00	75.00	5,925.00	75.00	5,925.00	50.00	3,950.00
23	Adjusting Sanitary Sewers, 8-Inch Diameter or Less	FOOT	80	40.00	3,200.00	55.00	4,400.00	5.00	400.00	75.00	6,000.00	35.00	2,800.00
24	Non-Shear Mission Couplings, 6"	EACH	16	150.00	2,400.00	44.00	704.00	30.00	480.00	48.00	768.00	55.00	880.00
25	Catch Basins, Type A, 4" Dia., Type R-3281-AL Frame and	EACH	1	3,000.00	3,000.00	3,000.00	3,000.00	4,000.00	4,000.00	3,800.00	3,800.00	3,800.00	3,800.00
26	Catch Basins, Type A, 5" Dia., Type R-3281-AL Frame and	EACH	1	4,000.00	4,000.00	4,800.00	4,800.00	5,000.00	5,000.00	4,400.00	4,400.00	4,200.00	4,200.00
27	Manholes, Type A, 5" Dia., Type 1 Frame, and Closed Lid	EACH	1	5,000.00	5,000.00	4,000.00	4,000.00	5,000.00	5,000.00	4,000.00	4,000.00	4,000.00	4,000.00
28	Connection to Existing Catch Basin	EACH	1	1,000.00	1,000.00	1,000.00	1,000.00	1,500.00	1,500.00	1,000.00	1,000.00	1,000.00	1,000.00
29	Disconnect and Plug Existing Storm Sewer, 18"	EACH	4	750.00	3,000.00	150.00	600.00	250.00	1,000.00	1,600.00	6,400.00	200.00	800.00
30	Removes Existing Storm Sewer, 18"	FOOT	10	50.00	500.00	10.00	100.00	15.00	150.00	25.00	250.00	15.00	150.00
31	Class D Patches, Type IV, 4"	SQ YD	627	40.00	25,080.00	51.00	31,977.00	32.00	20,064.00	48.00	30,096.00	65.00	40,755.00
32	Combination Curb and Gutter Removal	FOOT	60	5.00	300.00	10.00	600.00	1.00	60.00	8.00	480.00	10.00	600.00
33	Sidewalk Removal	SQ FT	125	3.00	375.00	5.00	625.00	1.00	125.00	2.00	250.00	2.00	250.00
34	Combination Concrete Curb and Gutter, Type M-4.12	FOOT	60	24.00	1,440.00	50.00	3,000.00	12.00	720.00	25.00	1,500.00	30.00	1,800.00
35	Portland Cement Concrete Sidewalk, 5 Inch	SQ FT	125	7.00	875.00	8.00	1,000.00	7.00	875.00	5.00	625.00	5.00	625.00
36	Detectable Warnings	SQ FT	30	30.00	900.00	35.00	1,050.00	20.00	600.00	40.00	1,200.00	50.00	1,500.00
37	Restoration, Complete	L SUM	1	5,000.00	5,000.00	5,000.00	5,000.00	8,500.00	8,500.00	7,200.00	7,200.00	5,000.00	5,000.00
38	Traffic Control & Protection	L SUM	1	3,000.00	3,000.00	9,000.00	9,000.00	15,000.00	15,000.00	6,000.00	6,000.00	2,000.00	2,000.00
39	Insurance Provision - Complete	L SUM	1	3,000.00	3,000.00	2,000.00	2,000.00	1,500.00	1,500.00	2,800.00	2,800.00	1,500.00	1,500.00
Totals :					225,852.00		224,981.00		237,669.00		254,262.00		280,330.00
Bid Error Corrections:													
Corrected Totals ---							224,981.00		237,669.00		254,262.00		280,330.00
Over / Under ----							-871.00		11,817.00		28,410.00		54,478.00
Percent ----							-0.39%		5.23%		12.58%		24.12%

to: Mayor Brian K. Reaves
Village Board of Trustees

from: James L. Cainkar, P.E., P.L.S., Acting Village Engineer

subject: **East Street Water Main Replacement at Short Street**

date: April 16, 2014

BACKGROUND/HISTORY

Fourteen (14) bids were received on April 15, 2014 @ 10:30 am for the East Street Water Main Replacement project (at Short Street), which work consists of the replacement of an existing 6-inch water main with a new 8-inch water main in trench; hydrants; valve vaults; water service reconnections; and all appurtenant construction.. The low bidder was Riccio Construction Company, which bid was in the amount of \$85,230.00. The bid was \$5,351.00 (5.91%) below the Engineer's Estimate of \$90,581.00.

RECOMMENDATION

Award of the East Street Water Main Replacement project to Riccio Construction Company based on their bid amount \$85,230.00, will allow the project to proceed on schedule.

ATTACHMENTS

- Resolution Authorizing Award of Contract
- Letter of Award Recommendation; and
- Bid Tabulation listing the bid received, including company name, address and amount of bid.

VILLAGE BOARD ACTION REQUIRED

Approval of Resolution awarding the contract to Riccio Construction Company.

RESOLUTION AUTHORIZING AWARD OF CONTRACT

**East Street Water Main Replacement
At Short Street**

WHEREAS, the Village of Lemont requires that the East Street Water Main Replacement project be completed; and

WHEREAS, the Village seeks to utilize the construction firm of Riccio Construction Company for such work; and

WHEREAS, Riccio Construction Company submitted a low bid for such work in the amount of \$85,230.00.

NOW, THEREFORE, BE IT RESOLVED, by the President and Board of Trustees that the Contract with Riccio Construction Company is hereby approved.

PASSED AND APPROVED BY THE PRESIDENT AND BOARD OF TRUSTEES OF THE VILLAGE OF LEMONT, COUNTIES OF COOK, WILL AND DuPAGE, ILLINOIS, on this 12th day of May, 2014.

AYES

NAYS

PASSED

ABSENT

Debby Blatzer
Paul Chialdikas
Clifford Miklos
Rick Sniegowski
Ronald Stapleton
Jeanette Virgilio

CHARLENE SMOLLEN, Village Clerk

Approved by me this 12th day of May, 2014.

A t t e s t:

BRIAN K. REAVES, Village President

CHARLENE SMOLLEN, Village Clerk



Frank Novotny & Associates, Inc.

825 Midway Drive ♦ Willowbrook, IL ♦ 60527 ♦ Telephone: (630) 887-8640 ♦ Fax: (630) 887-0132

Civil Engineers/
Municipal Consultants

Mr. George Schafer
Administrator
Village of Lemont
418 Main Street
Lemont, Illinois 60439

April 16, 2014

Re: **East Street Water Main Replacement at Short Street**
Bid Opening: April 15, 2014 at 10:30 am

Dear George:

Listed below and on the attached "Bid Tabulation", please find the results of the April 15, 2014 bid opening for the above-captioned project. Fourteen (14) bids were received and tabulated, with errors being found in one bid. A summary is as follows:

Riccio Construction	\$ 85,230.00
Unique Plumbing Company.....	92,441.25
Stip Brothers Excavating.....	93,953.00
Suburban General Construction.....	96,595.00
Len Cox & Sons Excavating.....	97,477.00
Superior Excavating	101,661.00
P.T. Ferro Construction.....	104,711.00
Vian Construction Company.....	108,623.00
Conley Excavating.....	113,753.00
City Construction Company.....	119,973.00
J. Congdon Sewer Services, Inc.....	126,688.00
Lifco Contractors, Inc.	127,143.00
Bisping Construction	181,609.94
Gerardi Sewer & Water	296,429.50
Engineer's Estimate.....	\$ 90,581.00

The low bid submitted by Riccio Construction, in the amount of \$85,230.00, is \$5,351.00 (5.91%) below the Engineer's Estimate of \$90,591.00. Since Riccio Construction is qualified to perform this type of work, we therefore recommend that the Contract be awarded to **Riccio Construction, P.O. Box 672, Palos Park, IL 60464**, in the amount of **\$85,230.00**.

Should you have any questions concerning this matter, please do not hesitate to contact me.

Very truly yours,

FRANK NOVOTNY & ASSOCIATES, INC.

James L. Cainkar, P.E., P.L.S.

JLC/dn

Enclosure

cc: Mr. Ralph Pukula, Director of Public Works, w/Enc.
Ms. Linda Molitor, Executive Assistant, w/Enc.
File No. 13388

TABULATION OF BIDS

OWNER: Village of Lemont
 PROJECT DESCRIPTION: East Street Water Main Replacement
 @ Short Street
 BID OPENING: April 15, 2014 at 10:30 am

PROJECT NO : 13388

				Engineers Estimate		Riccio Construction P.O. Box 672 Palos Park, IL 60464 5% Bid Bond		Unique Plumbing Co. 9408 W 47th Street Brookfield, IL 60513 5% Bid Bond		Stip Brothers Excavating 19042 W Manhattan Road Elwood, IL 60421 5% Bid Bond		Suburban General Constr. 1019 East 31st Street. LaGrange Park, IL 60526 5% Bid Bond		Len Cox & Sons Excavating 1203 Theodore Street Crest Hill, IL 60403 5% Bid Bond	
Item No	Description	Unit	Quantity	Unit Price	Amount	Unit Price	Amount	Unit Price	Amount	Unit Price	Amount	Unit Price	Amount	Unit Price	Amount
1	Water Main in Trench, Ductile Iron, 8"	FOOT	487	65.00	31,655.00	57.00	27,759.00	77.55	37,766.85	55.00	26,785.00	76.00	37,012.00	60.00	29,220.00
2	Polyethylene Encasement	FOOT	493	2.00	986.00	2.00	986.00	0.80	394.40	1.00	493.00	1.00	493.00	1.50	739.50
3	Valve Vaults, Type A, 5'-Dia.	EACH	2	4,000.00	8,000.00	2,250.00	4,500.00	2,500.00	5,000.00	3,190.00	6,380.00	3,500.00	7,000.00	2,000.00	4,000.00
4	Fire Hydrants	EACH	2	4,000.00	8,000.00	4,350.00	8,700.00	4,000.00	8,000.00	3,990.00	7,980.00	7,500.00	15,000.00	3,550.00	7,100.00
5	Pressure Connection, 8" x 8"	EACH	2	3,200.00	6,400.00	3,800.00	7,600.00	4,000.00	8,000.00	2,565.00	5,130.00	3,600.00	7,200.00	4,000.00	8,000.00
6	Disconnect and Cap Existing Water Main, 8"	EACH	2	800.00	1,600.00	1,820.00	3,640.00	1,800.00	3,600.00	2,300.00	4,600.00	3,500.00	7,000.00	2,900.00	5,800.00
7	Water Service Reconnection, 1-1/2"	EACH	2	800.00	1,600.00	1,315.00	2,630.00	1,800.00	3,600.00	1,420.00	2,840.00	1,500.00	3,000.00	2,000.00	4,000.00
8	Remove Existing Fire Hydrants	EACH	2	900.00	1,800.00	525.00	1,050.00	300.00	600.00	250.00	500.00	125.00	250.00	1,500.00	3,000.00
9	Combination Curb and Gutter Removal	FOOT	30	8.00	240.00	5.00	150.00	6.00	180.00	10.00	300.00	2.00	60.00	11.00	330.00
10	Pipe Fittings (Mechanical Joints), Ductile Iron	POUND	600	4.50	2,700.00	5.00	3,000.00	4.00	2,400.00	2.00	1,200.00	0.10	60.00	7.50	4,500.00
11	Filling Existing Valve Box	EACH	2	200.00	400.00	70.00	140.00	70.00	140.00	150.00	300.00	125.00	250.00	200.00	400.00
12	Selected Granular Backfill (CA-6)	CU YD	310	40.00	12,400.00	24.00	7,440.00	10.00	3,100.00	41.00	12,710.00	12.00	3,720.00	40.00	12,400.00
13	Pavement Removal, 9"	SQ YD	265	15.00	3,975.00	11.00	2,915.00	16.00	4,240.00	28.00	7,420.00	6.00	1,590.00	5.50	1,457.50
14	Combination Concrete Curb and Gutter, Type B-6.12	FOOT	30	35.00	1,050.00	32.00	960.00	40.00	1,200.00	60.00	1,800.00	12.00	360.00	85.00	2,550.00
15	Incidental Hot-Mix Asphalt Surfacing, 4"	SQ YD	265	35.00	9,275.00	44.00	11,660.00	48.00	12,720.00	51.00	13,515.00	35.00	9,275.00	42.00	11,130.00
16	Restoration	L SUM	1	500.00	500.00	2,100.00	2,100.00	1,500.00	1,500.00	2,000.00	2,000.00	4,325.00	4,325.00	2,850.00	2,850.00
Totals:					90,581.00		85,230.00		92,441.25		93,953.00		96,595.00		97,477.00
Bid Error Corrections:															
Corrected Totals ----							85,230.00		92,441.25		93,953.00		96,595.00		97,477.00
Over / Under ----							-5,351.00		1,860.25		3,372.00		6,014.00		6,896.00
Percent ----							-5.91%		2.05%		3.72%		6.64%		7.61%

TABULATION OF BIDS

OWNER: Village of Lemont
PROJECT DESCRIPTION: East Street Water Main Replacement
 @ Short Street
BID OPENING: April 15, 2014 at 10:30 am

PROJECT NO : 13388

Item No	Description	Unit	Quantity	Engineers Estimate		Superior Excavating P.O. Box 575 Channahon, IL 60410 5% Bid Bond		P.T. Ferro Construction P.O. Box 156 Joliet, IL 60434-0156 5% Bid Bond		Vian Construction Co., Inc. 1041 Martha Street Elk Grove Village, IL 60007 5% Bid Bond		Conley Excavating 1555 Gramercy Place Morris, IL 60450 5% Bid Bond		City Construction Company 4403 W Lawrence Ave, #205 Chicago, IL 60630 5% Bid Bond	
				Unit Price	Amount	Unit Price	Amount	Unit Price	Amount	Unit Price	Amount	Unit Price	Amount	Unit Price	Amount
1	Water Main in Trench, Ductile Iron, 8"	FOOT	487	65.00	31,655.00	74.00	36,038.00	70.00	34,090.00	80.00	38,960.00	85.00	41,395.00	70.00	34,090.00
2	Polyethylene Encasement	FOOT	493	2.00	986.00	1.00	493.00	2.00	986.00	1.00	493.00	1.00	493.00	1.00	493.00
3	Valve Vaults, Type A, 5'-Dia.	EACH	2	4,000.00	8,000.00	1,650.00	3,300.00	3,000.00	6,000.00	1,700.00	3,400.00	2,500.00	5,000.00	4,200.00	8,400.00
4	Fire Hydrants	EACH	2	4,000.00	8,000.00	4,200.00	8,400.00	5,000.00	10,000.00	3,960.00	7,920.00	4,300.00	8,600.00	4,200.00	8,400.00
5	Pressure Connection, 8" x 8"	EACH	2	3,200.00	6,400.00	3,700.00	7,400.00	4,500.00	9,000.00	5,400.00	10,800.00	4,000.00	8,000.00	3,500.00	7,000.00
6	Disconnect and Cap Existing Water Main, 8"	EACH	2	800.00	1,600.00	1,200.00	2,400.00	1,700.00	3,400.00	2,400.00	4,800.00	1,000.00	2,000.00	1,500.00	3,000.00
7	Water Service Reconnection, 1-1/2"	EACH	2	800.00	1,600.00	2,000.00	4,000.00	1,750.00	3,500.00	2,700.00	5,400.00	1,800.00	3,600.00	1,000.00	2,000.00
8	Remove Existing Fire Hydrants	EACH	2	900.00	1,800.00	600.00	1,200.00	1,500.00	3,000.00	300.00	600.00	500.00	1,000.00	550.00	1,100.00
9	Combination Curb and Gutter Removal	FOOT	30	8.00	240.00	10.00	300.00	5.00	150.00	8.00	240.00	10.00	300.00	10.00	300.00
10	Pipe Fittings (Mechanical Joints), Ductile Iron	POUND	600	4.50	2,700.00	9.00	5,400.00	3.50	2,100.00	5.00	3,000.00	10.00	6,000.00	10.00	6,000.00
11	Filling Existing Valve Box	EACH	2	200.00	400.00	100.00	200.00	150.00	300.00	250.00	500.00	250.00	500.00	1,235.00	2,470.00
12	Selected Granular Backfill (CA-6)	CU YD	310	40.00	12,400.00	46.00	14,260.00	45.00	13,950.00	30.00	9,300.00	28.00	8,680.00	25.00	7,750.00
13	Pavement Removal, 9"	SQ YD	265	15.00	3,975.00	11.00	2,915.00	10.00	2,650.00	13.00	3,445.00	18.00	4,770.00	85.00	22,525.00
14	Combination Concrete Curb and Gutter, Type B-6.12	FOOT	30	35.00	1,050.00	30.00	900.00	32.00	960.00	50.00	1,500.00	80.00	2,400.00	30.00	900.00
15	Incidental Hot-Mix Asphalt Surfacing, 4"	SQ YD	265	35.00	9,275.00	47.00	12,455.00	50.00	13,250.00	61.00	16,165.00	51.00	13,515.00	43.00	11,395.00
16	Restoration	L SUM	1	500.00	500.00	2,000.00	2,000.00	1,375.00	1,375.00	2,100.00	2,100.00	7,500.00	7,500.00	4,150.00	4,150.00
Totals:					90,581.00		101,655.00		104,711.00		108,623.00		113,753.00		119,973.00
Bid Error Corrections:															
Total.....							101,661.00								
Corrected Totals - - -							101,661.00		104,711.00		108,623.00		113,753.00		119,973.00
Over / Under - - -							11,080.00		14,130.00		18,042.00		23,172.00		29,392.00
Percent - - -							12.23%		15.60%		19.92%		25.58%		32.45%

TABULATION OF BIDS

OWNER: Village of Lemont
PROJECT DESCRIPTION: East Street Water Main Replacement
 @ Short Street
BID OPENING: April 15, 2014 at 10:30 am

PROJECT NO : 13388

				Engineers Estimate		J. Congdon Sewer Serv. 170-A Alexandra Way Carol Stream, IL 60188 5% Bid Bond		Lifco Contractors, Inc. P.O. Box 87200 Carol Stream, IL 60188 5% Bid Bond		Bisping Construction P.O. Box 664 New Lenox, IL 60451 5% Bid Bond		Gerardi Sewer & Water 4520 N Osage Norridge, IL 60706 5% Bid Bond			
Item No	Description	Unit	Quantity	Unit Price	Amount	Unit Price	Amount	Unit Price	Amount	Unit Price	Amount	Unit Price	Amount	Unit Price	Amount
1	Water Main in Trench, Ductile Iron, 8"	FOOT	487	65.00	31,655.00	100.00	48,700.00	100.00	48,700.00	162.01	78,898.87	400.00	194,800.00		
2	Polyethylene Encasement	FOOT	493	2.00	986.00	1.00	493.00	1.00	493.00	0.30	147.90	1.50	739.50		
3	Valve Vaults, Type A, 5'-Dia.	EACH	2	4,000.00	8,000.00	1,000.00	2,000.00	3,800.00	7,600.00	4,001.38	8,002.76	2,500.00	5,000.00		
4	Fire Hydrants	EACH	2	4,000.00	8,000.00	6,500.00	13,000.00	5,000.00	10,000.00	6,220.73	12,441.46	6,000.00	12,000.00		
5	Pressure Connection, 8" x 8"	EACH	2	3,200.00	6,400.00	4,500.00	9,000.00	6,500.00	13,000.00	7,856.25	15,712.50	6,750.00	13,500.00		
6	Disconnect and Cap Existing Water Main, 8"	EACH	2	800.00	1,600.00	2,500.00	5,000.00	1,500.00	3,000.00	5,785.78	11,571.56	1,675.00	3,350.00		
7	Water Service Reconnection, 1-1/2"	EACH	2	800.00	1,600.00	2,000.00	4,000.00	1,400.00	2,800.00	3,888.33	7,776.66	3,500.00	7,000.00		
8	Remove Existing Fire Hydrants	EACH	2	900.00	1,800.00	500.00	1,000.00	700.00	1,400.00	1,405.69	2,811.38	600.00	1,200.00		
9	Combination Curb and Gutter Removal	FOOT	30	8.00	240.00	10.00	300.00	10.00	300.00	27.77	833.10	5.00	150.00		
10	Pipe Fittings (Mechanical Joints), Ductile Iron	POUND	600	4.50	2,700.00	5.00	3,000.00	6.00	3,600.00	2.38	1,428.00	6.00	3,600.00		
11	Filling Existing Valve Box	EACH	2	200.00	400.00	200.00	400.00	100.00	200.00	357.00	714.00	150.00	300.00		
12	Selected Granular Backfill (CA-6)	CU YD	310	40.00	12,400.00	35.00	10,850.00	45.00	13,950.00	57.80	17,918.00	40.00	12,400.00		
13	Pavement Removal, 9"	SQ YD	265	15.00	3,975.00	10.00	2,650.00	15.00	3,975.00	11.90	3,153.50	16.00	4,240.00		
14	Combination Concrete Curb and Gutter, Type B-6.12	FOOT	30	35.00	1,050.00	75.00	2,250.00	35.00	1,050.00	101.15	3,034.50	75.00	2,250.00		
15	Incidental Hot-Mix Asphalt Surfacing, 4"	SQ YD	265	35.00	9,275.00	53.00	14,045.00	55.00	14,575.00	53.55	14,190.75	60.00	15,900.00		
16	Restoration	L SUM	1	500.00	500.00	10,000.00	10,000.00	2,500.00	2,500.00	2,975.00	2,975.00	20,000.00	20,000.00		
Totals:					90,581.00		125,688.00		127,143.00		181,609.94		296,429.50		
Bid Error Corrections:															
Corrected Totals - - -							125,688.00		127,143.00		181,609.94		296,429.50		
Over / Under - - -							36,107.00		36,562.00		91,028.94		205,848.50		
Percent - - -							39.86%		40.36%		100.49%		227.25%		

Village Board
Agenda Memorandum

Item #

to: Mayor Brian K. Reaves
Village Board of Trustees

from: James L. Cainkar, P.E., P.L.S., Acting Village Engineer

subject: **2014 CDBG Sidewalk Replacement – Block Group 3
CDBG Project No. 1306-014**

date: May 6, 2014

BACKGROUND/HISTORY

Seven (7) bids were received on May 6, 2014, at 10:00 a.m., for the "2014 CDBG Sidewalk Replacement – Block Group 3" project, which work consists of the replacement of various sections of public sidewalks, driveways, and stairway repairs within Block Group 3, which basically consists of the Downtown Lemont area, and adjacent residential environs. The low bidder was Addison Concrete, Inc., which bid was in the amount of \$282,240.00. The bid was \$15,525.00 (5.21%) below the Engineer's Estimate of \$297,765.00.

This project is being partially funded with \$250,000.00 in Community Development Block Grant Funds.

RECOMMENDATION

Award of the 2014 CDBG Sidewalk Replacement – Block Group 3 project to Addison Concrete, Inc., based on their bid amount \$282,240.00, will allow the project to proceed on schedule.

ATTACHMENTS

- Resolution Authorizing Award of Contract
- Letter of Award Recommendation; and
- Bid Tabulation listing the bid received, including company name, address and amount of bid.

VILLAGE BOARD ACTION REQUIRED

Approval of Resolution awarding the contract to Addison Concrete, Inc.

File No. 13268

RESOLUTION

RESOLUTION AUTHORIZING AWARD OF CONTRACT

**2014 CDBG Sidewalk Replacement – Block Group 3
CDBG Project No. 1306-014**

WHEREAS, the Village of Lemont requires that the 2014 CDBG Sidewalk Replacement – Block Group 3 project be completed; and

WHEREAS, the Village seeks to utilize the construction firm of Addison Concrete, Inc. for such work; and

WHEREAS, Addison Concrete, Inc. submitted a low bid for such work in the amount of \$282,240.00.

NOW, THEREFORE, BE IT RESOLVED, by the President and Board of Trustees that the Contract with Addison Concrete, Inc. is hereby approved.

PASSED AND APPROVED BY THE PRESIDENT AND BOARD OF TRUSTEES OF THE VILLAGE OF LEMONT, COUNTIES OF COOK, WILL AND DU PAGE, ILLINOIS, on this 12th day of May, 2014.

AYES

NAYS

PASSED

ABSENT

Debby Blatzer
Paul Chialdikas
Clifford Miklos
Rick Sniegowski
Ronald Stapleton
Jeanette Virgilio

CHARLENE SMOLLEN, Village Clerk

Approved by me this 12th day of May, 2014.

Attest:

BRIAN K. REAVES, Village President

CHARLENE SMOLLEN, Village Clerk

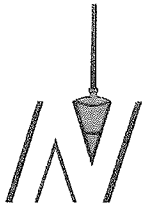

Frank Novotny & Associates, Inc.

825 Midway Drive ♦ Willowbrook, IL ♦ 60527 ♦ Telephone: (630) 887-8640 ♦ Fax: (630) 887-0132

Civil Engineers/
Municipal Consultants

May 6, 2014

Mr. George Schafer
Administrator
Village of Lemont
418 Main Street
Lemont, Illinois 60439

Re: **2014 CDBG Sidewalk Replacement – Block Group 3**
CDBG Project No. 1306-014

Dear George:

Listed below and on the attached "Tabulation of Bids", please find the results of the May 6, 2014, bid opening for the above-captioned project. Seven (7) bids were received and checked for accuracy, with errors found that affected the resultant bid order. A summary is as follows:

Addison Concrete.....	\$282,240.00
G&M Cement Construction.....	284,630.00
Suburban Concrete	287,875.00
D'Land Construction	288,187.50
Whiteline Construction.....	295,925.00
Davis Concrete Construction.....	302,451.10
Schroeder & Schroeder.....	311,645.00
Engineer's Estimate.....	\$297,765.00

The low bid submitted by Addison Concrete, Inc., in the amount of \$282,240.00, is \$15,525.00 (5.21%) below the Engineer's Estimate of \$297,765.00. Addison Concrete has satisfactorily performed this type of work under the supervision of our office in the past. We, therefore, recommend that the Contract be awarded to **Addison Concrete, Inc., 220 E. Lake Street, Suite 102, Addison, IL 60101**, in the amount of **\$282,240.00**.

This project is being partially funded with \$250,000.00 in Community Development Block Grant Funds.

Mr. George Schafer
May 6, 2014
Page Two

Should you have any questions concerning this matter, please do not hesitate to contact me.

Very truly yours,

FRANK NOVOTNY & ASSOCIATES, INC.

A handwritten signature in black ink, appearing to read 'JL Cainkar', with a long horizontal flourish extending to the right.

James L. Cainkar, P.E., P.L.S.

JLC/ce

Enclosure

cc: Mr. Ralph Pukula, Director of Public Works, w/Enc.
Ms. Linda Molitor, Executive Assistant, w/Enc.
File No. 13268

OWNER: Village of Lemont
 PROJECT DESCRIPTION: 2014 CDBG Sidewalk Replacement
 Block Group 3
 BID OPENING: May 6, 2013 @ 10:00 a.m.

PROJECT NO : 13268

Item No	Description	Unit	Quantity	Engineers Estimate		Addison Concrete 220 E. Lake Street, #102 Addison, IL 60101 5% Bid Bond		G&M Cement Construction 58 W. Commercial Road Addison, IL 60101 5% Bid Bond		Suburban Concrete 21227 W. Commercial Drive Mundelein, IL 60060 5% Bid Bond		D'Land Construction 600 S. County Line Road Bensenville, IL 60106 5% Bid Bond	
				Unit Price	Amount	Unit Price	Amount	Unit Price	Amount	Unit Price	Amount	Unit Price	Amount
1	Earth Excavation	CU YD	240	50.00	12,000.00	28.00	6,720.00	38.00	9,120.00	44.00	10,560.00	38.00	9,120.00
2	Sidewalk Removal	SQ FT	36500	1.00	36,500.00	1.50	54,750.00	1.00	36,500.00	1.35	49,275.00	1.05	38,325.00
3	Portland Cement Concrete Sidewalk, 5"	SQ FT	43000	3.75	161,250.00	3.25	139,750.00	4.00	172,000.00	4.00	172,000.00	4.00	172,000.00
4	Portland Cement Concrete Sidewalk, 7"	SQ FT	1500	5.50	8,250.00	6.50	9,750.00	4.00	6,000.00	4.00	6,000.00	4.00	6,000.00
5	Subbase Granular Material, Type B, 2" (For New Sidewalk)	SQ YD	900	5.00	4,500.00	7.00	6,300.00	2.50	2,250.00	2.50	2,250.00	7.75	6,975.00
6	Detectable Warnings	SQ FT	200	25.00	5,000.00	18.00	3,600.00	20.00	4,000.00	18.00	3,600.00	16.00	3,200.00
7	Protective Coat (Special)	SQ YD	5610	1.50	8,415.00	3.00	16,830.00	1.00	5,610.00	1.00	5,610.00	0.75	4,207.50
8	Hot-Mix Asphalt Driveway Pavement Removal	SQ YD	100	12.00	1,200.00	20.00	2,000.00	12.00	1,200.00	15.00	1,500.00	10.00	1,000.00
9	Incidental Hot-Mix Asphalt Surfacing (Driveways), 3"	TON	18	100.00	1,800.00	30.00	540.00	200.00	3,600.00	110.00	1,980.00	80.00	1,440.00
10	Combination Curb & Gutter Removal	FOOT	800	4.00	3,200.00	6.00	4,800.00	3.00	2,400.00	4.00	3,200.00	4.95	3,960.00
11	Combination Concrete Curb & Gutter, Type B-8.12	FOOT	550	18.00	9,900.00	18.00	9,900.00	15.00	8,250.00	12.00	6,600.00	14.95	8,222.50
12	Combination Concrete Curb & Gutter, Type B-8.18	EACH	250	23.00	5,750.00	20.00	5,000.00	17.00	4,250.00	15.00	3,750.00	17.75	4,437.50
13	Tie Bars	EACH	200	30.00	6,000.00	5.00	1,000.00	4.00	800.00	5.00	1,000.00	6.00	1,200.00
14	Concrete Driveway Pavement Removal	SQ YD	200	10.00	2,000.00	28.00	5,600.00	12.00	2,400.00	15.00	3,000.00	9.00	1,800.00
15	Portland Cement Concrete Driveway Pavement, 7"	SQ YD	200	45.00	9,000.00	34.00	6,800.00	40.00	8,000.00	32.50	6,500.00	40.00	8,000.00
16	Portland Cement Concrete Stair Removal	SQ FT	150	10.00	1,500.00	8.00	1,200.00	5.00	750.00	7.00	1,050.00	8.00	1,200.00
17	Portland Cement Concrete Stair (7" Height, 10" Depth)	SQ FT	150	70.00	10,500.00	8.00	1,200.00	10.00	1,500.00	20.00	3,000.00	12.00	1,800.00
18	Traffic Control & Protection, Standard 701501	L SUM	1	5,000.00	5,000.00	2,500.00	2,500.00	7,500.00	7,500.00	2,000.00	2,000.00	6,750.00	6,750.00
19	Traffic Control & Protection, Standard 701801	L SUM	1	3,000.00	3,000.00	2,500.00	2,500.00	7,500.00	7,500.00	3,500.00	3,500.00	6,750.00	6,750.00
20	Insurance Provisions - Complete	L SUM	1	3,000.00	3,000.00	1,500.00	1,500.00	1,000.00	1,000.00	1,500.00	1,500.00	1,800.00	1,800.00
Totals:					297,765.00		282,240.00		281,030.00		287,875.00		288,187.50
Bid Error Corrections:													
6	Detectable Warnings								4,000.00				
Total									284,630.00				
Corrected Totals ---							282,240.00		284,630.00		287,875.00		288,187.50
Over / Under ----							-15,525.00		-13,135.00		-9,890.00		-9,577.50
Percent ----							-5.21%		-4.41%		-3.32%		-3.22%

OWNER: Village of Lemont
 PROJECT DESCRIPTION: 2014 CDBG Sidewalk Replacement
 Block Group 3
 BID OPENING: May 6, 2013 @ 10:00 a.m.

PROJECT NO : 13268

Item No	Description	Unit	Quantity	Engineers Estimate		Whiteline Construction 332 Wedgewood Circle Romeoville, IL 60446 5% Bid Bond		Davis Concrete Construction 11633 S. Mayfield Avenue Alsip, IL 60803 5% Bid Bond		Schroeder & Schroeder 7306 Central Park Skokie, IL 60076 5% Bid Bond		Unit Price	Amount
				Unit Price	Amount	Unit Price	Amount	Unit Price	Amount	Unit Price	Amount		
1	Earth Excavation	CU YD	240	50.00	12,000.00	42.00	10,080.00	30.00	7,200.00	37.00	8,880.00		
2	Sidewalk Removal	SQ FT	36500	1.00	36,500.00	1.25	45,625.00	1.55	56,575.00	1.00	36,500.00		
3	Portland Cement Concrete Sidewalk, 5"	SQ FT	43000	3.75	161,250.00	4.00	174,000.00	4.05	174,150.00	4.25	182,750.00		
4	Portland Cement Concrete Sidewalk, 7"	SQ FT	1500	5.50	8,250.00	6.00	9,000.00	4.55	6,825.00	4.50	6,750.00		
5	Subbase Granular Material, Type B, 2" (For New Sidewalk)	SQ YD	900	5.00	4,500.00	2.50	2,250.00	3.30	2,970.00	3.50	3,150.00		
6	Detectable Warnings	SQ FT	200	25.00	5,000.00	22.00	4,400.00	13.00	2,600.00	37.00	7,400.00		
7	Protective Coat (Special)	SQ YD	5610	1.50	8,415.00	1.00	5,610.00	0.01	56.10	1.50	8,715.00		
8	Hot-Mix Asphalt Driveway Pavement Removal	SQ YD	100	12.00	1,200.00	9.00	900.00	17.50	1,750.00	6.00	600.00		
9	Incidental Hot-Mix Asphalt Surfacing (Driveways), 3"	TON	18	100.00	1,800.00	95.00	1,710.00	275.00	4,950.00	200.00	3,600.00		
10	Combination Curb & Gutter Removal	FOOT	800	4.00	3,200.00	3.00	2,400.00	10.00	8,000.00	3.00	2,400.00		
11	Combination Concrete Curb & Gutter, Type B-6.12	FOOT	550	18.00	9,900.00	18.00	9,900.00	17.25	9,487.50	17.00	9,350.00		
12	Combination Concrete Curb & Gutter, Type B-6.18	EACH	250	23.00	5,750.00	19.00	4,750.00	18.75	4,687.50	22.00	5,500.00		
13	Tie Bars	EACH	200	30.00	6,000.00	4.00	800.00	10.00	2,000.00	5.00	1,000.00		
14	Concrete Driveway Pavement Removal	SQ YD	200	10.00	2,000.00	10.00	2,000.00	15.00	3,000.00	8.00	1,600.00		
15	Portland Cement Concrete Driveway Pavement, 7"	SQ YD	200	45.00	9,000.00	54.00	10,800.00	41.00	8,200.00	40.00	8,000.00		
16	Portland Cement Concrete Stair Removal	SQ FT	150	10.00	1,500.00	3.00	450.00	10.00	1,500.00	15.00	2,250.00		
17	Portland Cement Concrete Stair (7" Height, 10" Depth)	SQ FT	150	70.00	10,500.00	25.00	3,750.00	20.00	3,000.00	65.00	9,750.00		
18	Traffic Control & Protection, Standard 701501	L SUM	1	5,000.00	5,000.00	4,000.00	4,000.00	2,500.00	2,500.00	7,500.00	7,500.00		
19	Traffic Control & Protection, Standard 701801	L SUM	1	3,000.00	3,000.00	3,000.00	3,000.00	2,500.00	2,500.00	2,500.00	2,500.00		
20	Insurance Provisions - Complete	L SUM	1	3,000.00	3,000.00	2,500.00	2,500.00	500.00	500.00	3,750.00	3,750.00		
Totals:					297,765.00		297,925.00		302,451.10		311,945.00		
Bid Error Corrections:													
3	Portland Cement Concrete Sidewalk, 5"						172,000.00				8,415.00		
7	Protective Coat (Special)										9,750.00		
Total.....							295,925.00				311,645.00		
Corrected Totals - - -							295,925.00		302,451.10		311,645.00		
Over / Under - - - -							-1,840.00		4,686.10		13,880.00		
Percent - - - -							-0.62%		1.57%		4.66%		