

Village of Lemont

Mayor
Brian K. Reaves

Village Clerk
Charlene Smollen

Administrator
George J. Schafer



Trustees
Debby Blatzer
Paul Chialdikas
Clifford Miklos
Rick Sniegowski
Ronald Stapleton
Jeanette Virgilio

VILLAGE BOARD MEETING
September 8, 2014 – 7:00 PM
Village Hall – 418 Main Street

AGENDA

- I. PLEDGE OF ALLEGIANCE**
- II. ROLL CALL**
- III. CONSENT AGENDA**
 - A. APPROVAL OF MINUTES**
 - 1. AUGUST 11, 2014 VILLAGE BOARD MEETING MINUTES**
 - 2. AUGUST 18, 2014 COMMITTEE OF THE WHOLE MEETING MINUTES**
 - B. APPROVAL OF DISBURSEMENTS**
 - C. AN ORDINANCE AMENDING LEMONT MUNICIPAL CODE: LIQUOR LICENSES (CLASS C-3 LICENSES)**
- IV. MAYOR'S REPORT**
 - A. AUDIENCE PARTICIPATION**
- V. CLERK'S REPORT**
 - A. CORRESPONDENCE**
 - B. ORDINANCE**
 - 1. AN ORDINANCE GRANTING A SPECIAL USE FOR A PLANNED UNIT DEVELOPMENT (PUD) FOR CHICAGO BLAZE RUGBY CLUB AT 13011 SMITH ROAD IN LEMONT, IL (PLANNING & ED)(STAPLETON)(JONES/GLAS)**
 - C. RESOLUTION**
 - 1. A RESOLUTION AUTHORIZING AWARD OF CONTRACT – SMITH FARMS DETENTION BASIN REPAIRS (PUBLIC WORKS)(BLATZER)(PUKULA)**

- 2. A RESOLUTION AUTHORIZING AWARD OF CONTRACT – BUILDING DEMOLITION (AT IL ROUTE 83 & MAIN STREET)
(PUBLIC WORKS)(BLATZER)(PUKULA)**
- 3. A RESOLUTION AUTHORIZING AWARD OF CONTRACT - 2014 SANITARY SEWER & STORM SEWER CLEANING & TELEVISIONING
(PUBLIC WORKS)(BLATZER)(PUKULA)**

- VI. VILLAGE ATTORNEY REPORT**
- VII. VILLAGE ADMINISTRATOR REPORT**
- VIII. BOARD REPORTS**
- IX. STAFF REPORTS**
- X. UNFINISHED BUSINESS**
- XI. NEW BUSINESS**
- XII. MOTION FOR EXECUTIVE SESSION**
- XIII. ACTION ON CLOSED SESSION ITEM(S)**
- XIV. MOTION TO ADJOURN**

Minutes
VILLAGE BOARD MEETING
Village Hall – 418 Main Street
August 11, 2014
7:00 p.m.

The regular meeting of the Lemont Village Board was held on Monday, August 11, 2014, at 7:00 p.m., presided by Pro Tem Debby Blatzer.

I. PLEDGE OF ALLEGIANCE

II. ROLL CALL

Roll call: Chialdikas, Miklos, Sniegowski, Stapleton, Blatzer; present. Virgilio, absent

III. CONSENT AGENDA

Motion by Stapleton, seconded by Chialdikas, to approve the following items on the consent agenda by omnibus vote:

A. Approval of Minutes

1. July 28, 2014 Village Board Meeting Minutes

B. Approval of Disbursements

C. Ordinance O-42-14 Amending Lemont Municipal Code Chapter 5.04, Section 5.04.060.B: Alcoholic Beverages (Decreasing Number of Class A-7 Liquor Licenses)

D. Resolution R-51-14 Authorizing a Partial Termination of Recapture Agreement.

Roll Call: Chialdikas, Miklos, Sniegowski, Stapleton, Blatzer; 5 ayes. Motion Passed. Virgilio, absent.

IV. MAYOR'S REPORT

- A. Electric Aggregation – Hugh O’Hara from the Will County Governmental League spoke of the new electric supplier that was chose. The current contract with First Energy Solutions will expire in October. Homefield Energy was chosen with a rate of \$0.06996/kWh for the first 24 months and then a rate of \$0.06850/kWh for months 24-36. Savings will still exist for residents.

V. CLERK'S REPORT

A. **CORRESPONDENCE - NONE**

B. **ORDINANCE**

1. Ordinance O-43-14 Granting Final Plan/Plat Approval for a Residential Planned Unit Development on an 131.14 Acre Parcel Located at Parker Road and 131st Street, in Lemont, IL (Kettering) Motion by Chialdikas, seconded by Miklos, to adopt said ordinance. Roll call: Chialdikas, Miklos, Sniegowski, Stapleton, Blatzer; 5 ayes. Motion Passed. Virgilio, absent.

C. Resolution

1. Resolution R-52-14 Approving a Final Plat of Subdivision for Property at Parker Road and 131st Street, in Lemont, IL (Kettering Unit One). Motion by Chialdikas, seconded by Sniegowski to adopt said Resolution. Roll call: Chialdikas, Miklos, Sniegowski, Stapleton, Blatzer; 5 ayes. Motion Passed. Virgilio, absent.
2. Resolution R-53-14 Approving a Final Plat of Subdivision for Property at Parker Road and 131st Street, in Lemont, IL (Kettering Unit Two). Motion by Stapleton, second Miklos, to adopt said resolution. Roll call: Chialdikas, Miklos, Sniegowski, Stapleton, Blatzer; 5 ayes. Motion Passed. Virgilio, absent.
3. Resolution R-54-14 Approving a Grant Agreement with CITGO Petroleum Corporation. Motion by Chialdikas, second Miklos, to adopt said resolution. Roll call: Chialdikas, Miklos, Sniegowski, Stapleton, Blatzer; 5 ayes. Motion Passed. Virgilio, absent.

VI. VILLAGE ATTORNEY REPORT

VII. VILLAGE ADMINISTRATOR REPORT

- A. There will be no festival or parade for Keepataw Days this Labor Day.

VIII. BOARD REPORTS

- A. Moody's bond rating agency has rated the Village as a Aa2 category, which is a plus for our community.

IX. STAFF REPORTS

A. **POLICE DEPARTMENT**

1. Spoke of the great partnership with CITGO.
2. School starts next week and reminded residents of school safety.
3. Kops- N-Kidz event was a success last weekend.

X. UNFINISHED BUSINESS

XI. NEW BUSINESS

XII. MOTION FOR EXECUTIVE SESSION

XIII. ACTION ON CLOSED SESSION ITEM

XIV. MOTION TO ADJOURN

There being no further business, a motion was made by Stapleton, seconded by Sniegowski, to adjourn the meeting at 7:30 p.m. Voices vote; 5 ayes. Motion passed.

Village Board
Committee of the Whole Meeting
August 18, 2014 – 7:00 PM

A meeting of the Village of Lemont Committee of the Whole was held on August 18, 2014 at the Village Hall at 418 Main Street, Lemont, IL

- I. **Call to Order** - Mayor Reaves called the meeting to order at 7:00 p.m.

- II. **Roll Call** - Trustees Debby Blatzer, Paul Chialdikas, Cliff Miklos, Rick Sniegowski, Ron Stapleton, Jeanette Virgilio. Also present, George Schafer, Martha Glas, Charity Jones, Mark LaChappell, Ralph Pukula, Kevin Shaughnessy, Chris Smith (Linda Molitor arrived at 8:00 pm)

- III. **Discussion Items**
 - A. **Chicago Blaze Rugby Club PUD Revision**

Chicago Blaze Rugby Club's PUD was initially heard by the Planning and Zoning Commission in May and at the COW in June. An accessory building with a two car garage that they use for storage of lawn equipment was allowed to remain. Since then, this structure was damaged by a storm. Chicago Blaze wants to now make this garage a three car garage for additional storage. Discussion took place regarding the location of the garage and which way the doors could face. Board consensus was to allow the three car garage and allow the doors to face Smith Road. The final PUD will be up for approval at a future Village Board Meeting.

 - B. **Lemont 2030 – Future Land Use Map**

Revisions were made to the map from input at the July COW meeting. There were no further revision requests by the Board.

 - C. **Strategic Plan Progress and Update**

Various key performance indicators of the components from the strategic plan were discussed for clarification and direction (see agenda item memo.) Feedback from these items will redefine these performance indicators and action items as necessary. The majority of the staff recommended changes to the plan we agreed upon by the Board. Sections in need of further discussion and clarification include the economic development and financial stability indicators. These will be discussed at a future workshop meeting.

 - D. **La Dolce Vita Outdoor Dining Request**

The restaurant currently has an outdoor canopy seating area that is attached to their building. Mickey Martin represented La Dolce Vita. The owners want to now include a plastic roll down cover that would allow usage all year round. In addition, they want to remove the concrete slab and put a patio deck with composite material to make it level. This deck would extend over the existing pavers, part of which is on Village property.

This will allow for 5 more seating tables outdoor, as they have to turn customers away for lack of seating. It will include an ADA ramp and two emergency exits with lights.

They want to do things to increase revenue to draw more people in, and see it as bringing people to the downtown.

Village Administrator, George Schafer stated they would need a license to use Village property to serve. Building code and ADA requirements will be met. The Village Board discussed the request and the intent of the open air structure with the rollaway covering, which could be closed in inclement weather. Also, the license, if issued, could be revocable based upon change of ownership. There was a concern to accommodate other businesses with similar requests and the loss of room on the sidewalk. The business also needs to increase its revenue in order to do the other upgrades; they are willing to invest in their business.

Trustee Stapleton made mention of items that were not done through the Building Department. The owner noted the items were done to code and will first come to the Village with all further changes/updates. Trustee Stapleton is not in favor of the canopy, and added that it blocks the view of the other business.

Board majority was to approve the installation of the rollaway covering and deck providing all provisions of the building code are met and that the agreement can be revocable upon change in ownership. The owners may have to bring this before the Historical Society for the door item.

E. Route 83 and Main Development Process

The Planning and Economic Development Director talked with SB Friedman and Gruen Gruen + Associates. Staff will meet and discuss all the firms.

IV. Unfinished Business

- A. Emerald Ash Borer Update – Homer Tree Service has finished with Gladys subdivision and will continue with the others.
- B. Trail Maintenance – Public Works is working on maintenance of the trail.

V. New Business

- A. Bonds – On August 18, 2014, we sold the refunding and restructuring bonds. The sale was very successful; originally it was thought we would have a savings of \$5,600, however our actual savings was \$21,000.
- B. Newsletter – Staff is obtaining quotes for printing and mailing of the newsletter. Depending on the cost difference, a company outside of town may be selected. It is also being considered to change the paper quality to a lower grade than the glossy which would be cheaper and less cost to mail.
- C. Bridge Work – Rauch construction informed us that the cracks they have to fill and repair have gotten larger since May. There may be a cost overrun, and they have to close the bridge down for a few weeks. They are looking at mid-September. The Lemont Road bridge has collected more debris from the river, so that is another time and material issue.

Lemont, IL
Warrant list

Bank Account: FM-Clearing - Accounts Payable

Batch Date: 08/25/2014

Type	Date	Number Source	Payee Name	EFT Bank/Account	Transaction Amount
Bank Account: FM-Clearing - Accounts Payable					
Check	08/25/2014	10470 Accounts Payable	5th Avenue Construction		1,000.00
	Invoice	Date	Description		Amount
		2013-00010289	08/11/2014	refund clean-up bond - 12758 Dunmoor Dr	1,000.00
Check	08/25/2014	10471 Accounts Payable	Amalgamated Bank of Chicago		515.00
	Invoice	Date	Description		Amount
		14-08-01 4008	08/01/2014	Series 2007 bond service fees #4008	515.00
Check	08/25/2014	10472 Accounts Payable	Arthur Peterson, Inc.		235.13
	Invoice	Date	Description		Amount
		14-07-31	07/31/2014	Jul 2014 supply purchases	235.13
Check	08/25/2014	10473 Accounts Payable	AT&T Capital Services, Inc.		295.84
	Invoice	Date	Description		Amount
		2928690	08/02/2014	001-5284700-001 - iPads lease payment	295.84
Check	08/25/2014	10474 Accounts Payable	AT&T Illinois		55.00
	Invoice	Date	Description		Amount
		14-08-9005	08/02/2014	126379005 - metra station internet	55.00
Check	08/25/2014	10475 Accounts Payable	AT&T Mobility		4,912.24
	Invoice	Date	Description		Amount
		07112014	07/03/2014	287249463396 - p.w. cell phone service	2,545.75
		08112014	08/03/2014	287249463396 - p.w. cell phone service	2,366.49
Check	08/25/2014	10476 Accounts Payable	Avalon Petroleum Company		10,025.10
	Invoice	Date	Description		Amount
		453422	08/01/2014	1800 gals reg fuel	5,112.00
		147988	08/01/2014	1590 gals dsl fuel	4,913.10
Check	08/25/2014	10477 Accounts Payable	Barco Products Company		2,395.89
	Invoice	Date	Description		Amount
		061401368	07/31/2014	picnic tables for Budnik Plaza	2,395.89
Check	08/25/2014	10478 Accounts Payable	Bruce , Susan M.		38.89
	Invoice	Date	Description		Amount

Lemont, IL
Warrant list

Bank Account: FM-Clearing - Accounts Payable

Batch Date: 08/25/2014

Type	Date	Number Source	Payee Name	EFT Bank/Account	Transaction Amount
	14-08-15		08/15/2014	reimburse - Oriental Trading - H'ween Hoedown, Hometown Holiday	38.89
Check	08/25/2014	10479 Accounts Payable	C.E.S. (City Electric Supply Co-MA)		196.40
	Invoice		Date	Description	Amount
	ROM/023922		08/01/2014	light parts	196.40
Check	08/25/2014	10480 Accounts Payable	Call One		1,498.17
	Invoice		Date	Description	Amount
	14-08-15		08/15/2014	1010-7801-0000 v.h., p.d., p.w. phones	1,498.17
Check	08/25/2014	10481 Accounts Payable	Casey Equipment Co., Inc.		191.89
	Invoice		Date	Description	Amount
	C02007		08/01/2014	parts	191.89
Check	08/25/2014	10482 Accounts Payable	Castletown Homes, Inc.		6,500.00
	Invoice		Date	Description	Amount
	120933		08/13/2014	refund - clean-up bond - 1158 128th St	1,000.00
	120933(T)		08/13/2014	refund - Temp CO bond - 1158 128th St	500.00
	120933(L)		08/13/2014	refund - Landscape bond - 1158 128th St	5,000.00
Check	08/25/2014	10483 Accounts Payable	Chase Cardmember Service		3,421.69
	Invoice		Date	Description	Amount
	070714-080614		08/06/2014	Jul 2014 Visa purchases	3,421.69
Check	08/25/2014	10484 Accounts Payable	Chicago Materials Corp.		9,353.26
	Invoice		Date	Description	Amount
	93117MB		07/23/2014	blacktop	4,111.89
	93222MB		07/31/2014	blacktop for alleys	5,241.37
Check	08/25/2014	10485 Accounts Payable	Chicago Street CCDD, LLC		1,470.00
	Invoice		Date	Description	Amount
	9104		08/11/2014	dumping fees	1,470.00
Check	08/25/2014	10486 Accounts Payable	Chipain's Finer Foods		12.72
	Invoice		Date	Description	Amount
	14-08-04		08/04/2014	0066 - 7 bags of ice	12.72
Check	08/25/2014	10487 Accounts Payable	Circle Tractor		296.17

Lemont, IL
Warrant list

Bank Account: FM-Clearing - Accounts Payable

Batch Date: 08/25/2014

Type	Date	Number Source	Payee Name	EFT Bank/Account	Transaction Amount
	Invoice		Date	Description	Amount
	01-159226		07/11/2014	supplies	113.44
	01-160724		08/04/2014	parts	182.73
Check	08/25/2014	10488 Accounts Payable		Closed Circuit Innovations	1,150.00
	Invoice		Date	Description	Amount
	5478		08/02/2014	Sep 2014	1,150.00
Check	08/25/2014	10489 Accounts Payable		Comcast Cable	500.31
	Invoice		Date	Description	Amount
	14-08-9805		08/04/2014	8771 20 147 0039805 v.h. cable/internet	251.33
	14-08-2700		08/04/2014	8771 20 147 0042700 p.d. cable/internet	248.98
Check	08/25/2014	10490 Accounts Payable		ComEd	167.48
	Invoice		Date	Description	Amount
	14-08-3016		08/04/2014	9338003016 - street lights - houston 1N schultz	17.75
	14-08-7033		08/05/2014	2213017033 - street lights - bell rd, main st	96.53
	14-08-2063		08/06/2014	1443022063 - street lights - KA Steel path	29.78
	14-08-0155		08/07/2014	1515080155 - street lights - 451 Talcott	23.42
Check	08/25/2014	10491 Accounts Payable		Constellation NewEnergy, Inc.	2,780.04
	Invoice		Date	Description	Amount
	0016478482		07/31/2014	1-KYU1QT - street lights - Lite Rte 25	1,630.09
	0016584920		08/05/2014	1-KYU1OZ - street lights - w/s stephen st 1 N	16.87
	0016566962		08/05/2014	1-KYU1O2 - street lights - ed bossert dr	9.81
	0016566953		08/05/2014	1-KYU1PW - street lights - 164 e peiffer ave	117.05
	0016584918		08/05/2014	1-KYU1RQ - street lights - 0 stephen st	303.81
	0016591043		08/06/2014	1-KYU1N5 - street lights - 411 singer ave rear	236.30
	0016546371		08/03/2014	1-KYU1M8 - street lights - 44 stevens st unit lts	54.91
	0016644170		08/08/2014	1-KYU1KE - street lights - 0 N new ave, 101 main st	192.56
	0016644156		08/08/2014	1-KYU1LB - street lights- 47 stevens st	36.70
	0016746770		08/12/2014	1-KYU1JH - street lights - 55 stephen st	181.94
Check	08/25/2014	10492 Accounts Payable		Desplaines Valley News	360.40
	Invoice		Date	Description	Amount
	9800		08/07/2014	Public Notice	360.40

Lemont, IL
Warrant list

Bank Account: FM-Clearing - Accounts Payable

Batch Date: 08/25/2014

Type	Date	Number Source	Payee Name	EFT Bank/Account	Transaction Amount
Check	08/25/2014	10493 Accounts Payable	Document Destruction Co., Inc.		92.50
	Invoice	Date	Description		Amount
		36393	08/03/2014	data destruction	92.50
Check	08/25/2014	10494 Accounts Payable	Dustcatchers, Inc.		106.98
	Invoice	Date	Description		Amount
		85681	08/07/2014	2055 - v.h. carpet mats	38.88
		85682	08/07/2014	2052 - p.d. carpet mat service	68.10
Check	08/25/2014	10495 Accounts Payable	Engineering Resource Associates Inc		10,033.56
	Invoice	Date	Description		Amount
		140303.02	06/17/2014	IMTT Culvert Engineering	3,546.82
		140303.01	05/19/2014	IMTT Culvert Engineering	2,289.90
		140303.03	07/29/2014	IMTT Culvert Engineering	4,196.84
Check	08/25/2014	10496 Accounts Payable	Esri, Inc.		1,500.00
	Invoice	Date	Description		Amount
		92848524	07/29/2014	337728 - GIS license	1,500.00
Check	08/25/2014	10497 Accounts Payable	ETP Labs Inc./EnviroTest/Perry Laboratories Inc.		224.00
	Invoice	Date	Description		Amount
		14-130431	08/01/2014	Sample testing	224.00
Check	08/25/2014	10498 Accounts Payable	FedEx		30.99
	Invoice	Date	Description		Amount
		2-739-63081	08/06/2014	3612-5837-1 - shipping	30.99
Check	08/25/2014	10499 Accounts Payable	First Communications		1,483.51
	Invoice	Date	Description		Amount
		12484461	08/05/2014	1FC022002003109	1,483.51
Check	08/25/2014	10500 Accounts Payable	Glas , Martha M		13.75
	Invoice	Date	Description		Amount
		14-08-13	08/13/2014	reimbursement - IDOR Sales Tax meeting travel	13.75
Check	08/25/2014	10501 Accounts Payable	Grainger		5.62

Lemont, IL
Warrant list

Bank Account: FM-Clearing - Accounts Payable

Batch Date: 08/25/2014

Type	Date	Number Source	Payee Name	EFT Bank/Account	Transaction Amount
		41629	07/24/2014	Traffic signals	2,185.45
Check	08/25/2014	10509 Accounts Payable	Imperial Service Systems Inc		1,127.50
		Invoice	Date	Description	Amount
		77890	08/01/2014	cleaning service @ P.D. & parking garage	1,009.00
		78243	07/31/2014	carpet cleaning @ Police Facility	118.50
Check	08/25/2014	10510 Accounts Payable	IPELRA		55.00
		Invoice	Date	Description	Amount
		14-07-25	07/25/2014	3/19/14 HR training - E Donahue	55.00
Check	08/25/2014	10511 Accounts Payable	J.G. Uniforms Inc		44.00
		Invoice	Date	Description	Amount
		34487	08/08/2014	uniforms - CSO Truhlar	44.00
Check	08/25/2014	10512 Accounts Payable	K&A Lawn Care & General Services		110.00
		Invoice	Date	Description	Amount
		1234	07/30/2014	Heritage Quarries mowing	110.00
Check	08/25/2014	10513 Accounts Payable	K-Five Construction Corporation		291,612.82
		Invoice	Date	Description	Amount
		13389-1	08/11/2014	2014 MFT resurfacing pgm	291,612.82
Check	08/25/2014	10514 Accounts Payable	Kallemeyn Collision Center		1,857.73
		Invoice	Date	Description	Amount
		14-08-15	08/06/2014	vehicle repair	1,857.73
Check	08/25/2014	10515 Accounts Payable	Kelly Overhead Doors, Inc.		875.00
		Invoice	Date	Description	Amount
		15218	03/01/2014	gate repair at police facility	875.00
Check	08/25/2014	10516 Accounts Payable	Launch Digital Marketing, LLC		250.00
		Invoice	Date	Description	Amount
		0005145	08/05/2014	ilivelemont blog	250.00
Check	08/25/2014	10517 Accounts Payable	Lemont Ace Hardware		531.32
		Invoice	Date	Description	Amount

Lemont, IL
Warrant list

Bank Account: FM-Clearing - Accounts Payable

Batch Date: 08/25/2014

Type	Date	Number Source	Payee Name	EFT Bank/Account	Transaction Amount
	7/31/14		07/31/2014	3542--July 2014 purchases-TSO supplies	215.84
	14-07-31		07/31/2014	3960--July 2014 purchases- Maint supplies	315.48
Check	08/25/2014	10518 Accounts Payable		Lemont Express Car Wash, LLC	315.00
	Invoice		Date	Description	Amount
	14-08-06 LEMA		07/31/2014	Aug 2014 vehicle washes	10.00
	14-08-06		07/31/2014	July 14 vehicle washes-P.D.	305.00
Check	08/25/2014	10519 Accounts Payable		Lemont High School Band Parents Association	1,500.00
	Invoice		Date	Description	Amount
	2013.		08/20/2014	Mayor's Charity Fund award - repl ck #6449	1,500.00
Check	08/25/2014	10520 Accounts Payable		Lexis Nexis Risk Data Management	85.50
	Invoice		Date	Description	Amount
	1354915-20140731		07/31/2014	Searches	85.50
Check	08/25/2014	10521 Accounts Payable		Ludwig's Inc.	39.98
	Invoice		Date	Description	Amount
	14-07-02		07/02/2014	propane tanks	39.98
Check	08/25/2014	10522 Accounts Payable		McMaster-Carr Supply Co.	253.84
	Invoice		Date	Description	Amount
	97133155		08/06/2014	supplies	253.84
Check	08/25/2014	10523 Accounts Payable		Menards	214.57
	Invoice		Date	Description	Amount
	47015		08/01/2014	pothole patch	104.70
	47384		08/07/2014	tools	109.87
Check	08/25/2014	10524 Accounts Payable		Metropolitan Industries Inc	1,106.00
	Invoice		Date	Description	Amount
	0000288016		07/31/2014	V.H. Elevator Sump Pump	1,106.00
Check	08/25/2014	10525 Accounts Payable		Morris Engineering, Inc.	6,030.00
	Invoice		Date	Description	Amount
	14-04332		08/06/2014	Jul 2014 reviews & inspections	6,030.00

Lemont, IL
Warrant list

Bank Account: FM-Clearing - Accounts Payable

Batch Date: 08/25/2014

Type	Date	Number Source	Payee Name	EFT Bank/Account	Transaction Amount
Check	08/25/2014	10526 Accounts Payable	Muffins Ice Cream Shoppe		750.00
	Invoice	Date	Description		Amount
	1014	08/05/2014	ice cream for Kops N Kidz event		750.00
Check	08/25/2014	10527 Accounts Payable	Nicholson , Myron		555.49
	Invoice	Date	Description		Amount
	14-08-18	08/18/2014	2013 property tax rebate		555.49
Check	08/25/2014	10528 Accounts Payable	NiCor Gas		145.78
	Invoice	Date	Description		Amount
	14/08-2000 4	08/01/2014	04-46-52-2000 4 well #4		21.53
	14/08-1000 5	08/13/2014	84-38-99-1000 5 chestnut crossing l/s		24.83
	14/08-20008	08/13/2014	85-71-20-20008 keepataw trails l/s		23.15
	14/08-2000 6	08/11/2014	69-98-10-2000 6 oak tree ln l/s		52.28
	14/08-2000 8	08/12/2014	74-12-00-2000 8 harpers grove l/s		23.99
Check	08/25/2014	10529 Accounts Payable	North American Salt Co.		4,570.07
	Invoice	Date	Description		Amount
	71202244	08/06/2014	salt		2,207.99
	71202775	08/07/2014	salt		2,362.08
Check	08/25/2014	10530 Accounts Payable	OfficeMax Incorporated		121.81
	Invoice	Date	Description		Amount
	441059	08/11/2014	1st floor office supplies		21.82
	565860	08/15/2014	supplies		99.99
Check	08/25/2014	10531 Accounts Payable	Patten Industries Inc.		56.40
	Invoice	Date	Description		Amount
	P35C0043023	07/31/2014	parts		56.40
Check	08/25/2014	10532 Accounts Payable	PDC Laboratories		151.50
	Invoice	Date	Description		Amount
	775809	07/31/2014	sample testing		151.50
Check	08/25/2014	10533 Accounts Payable	Pitney Bowes		636.00
	Invoice	Date	Description		Amount

Lemont, IL
Warrant list

Bank Account: FM-Clearing - Accounts Payable

Batch Date: 08/25/2014

Type	Date	Number Source	Payee Name	EFT Bank/Account	Transaction Amount
		4026308-AU14	08/13/2014	4026308 - quarterly postage meter rental	636.00
Check	08/25/2014	10534 Accounts Payable	Plows Council on Aging		50.00
	Invoice		Date	Description	Amount
		14-08-15	08/15/2014	2014 sponsorship ad	50.00
Check	08/25/2014	10535 Accounts Payable	Purchase Advantage Card		74.10
	Invoice		Date	Description	Amount
		14-07-24	07/24/2014	Jul 2014 supply purchases - P.W.	74.10
Check	08/25/2014	10536 Accounts Payable	Quill Corporation		108.47
	Invoice		Date	Description	Amount
		5082735	08/07/2014	ruled pads	8.49
		5235159	08/13/2014	check stock	99.98
Check	08/25/2014	10537 Accounts Payable	Rag's Electric		5,882.12
	Invoice		Date	Description	Amount
		9550	07/30/2014	Light Parts	496.50
		9454	08/04/2014	light repair	2,338.72
		9554-2	08/06/2014	light repair	3,046.90
Check	08/25/2014	10538 Accounts Payable	Rainbow Printing		275.35
	Invoice		Date	Description	Amount
		410637	08/13/2014	envelopes	175.95
		410638	08/13/2014	meter forms printing	51.50
		410628	08/08/2014	self-inking stamps	47.90
Check	08/25/2014	10539 Accounts Payable	Ray O'Herron Co., Inc.		161.93
	Invoice		Date	Description	Amount
		1444545-IN	08/11/2014	CSO uniform patches	4.00
		1444258-IN	08/08/2014	TSO uniforms	68.95
		1445262-IN	08/14/2014	uniforms - CSO	88.98
Check	08/25/2014	10540 Accounts Payable	RCM Data Corporation		229.48
	Invoice		Date	Description	Amount
		IN49730	08/11/2014	HP LJ 425-4350 toner cartridge	229.48
Check	08/25/2014	10541 Accounts Payable	Riccio Construction Corp.		128,182.79

Lemont, IL
Warrant list

Bank Account: FM-Clearing - Accounts Payable

Batch Date: 08/25/2014

Type	Date	Number Source	Payee Name	EFT Bank/Account	Transaction Amount
	Invoice		Date	Description	Amount
	13391-2SF		08/01/2014	water main replacement	93,849.65
	13337-3SF		08/01/2014	water main replacement	34,333.14
Check	08/25/2014	10542 Accounts Payable		Royal Plumbing, Inc.	740.00
	Invoice		Date	Description	Amount
	5272		08/06/2014	RPZ testing	740.00
Check	08/25/2014	10543 Accounts Payable		ServiceMaster By Bouck	2,721.00
	Invoice		Date	Description	Amount
	5717278		08/01/2014	village hall, safety village, metra station	2,550.00
	5717279		08/01/2014	janitorial supplies	171.00
Check	08/25/2014	10544 Accounts Payable		Shaw Media	658.00
	Invoice		Date	Description	Amount
	07141007458		07/31/2014	Village page	658.00
Check	08/25/2014	10545 Accounts Payable		Sosin & Arnold, Ltd.	1,000.00
	Invoice		Date	Description	Amount
	85599		07/31/2014	2539.001 - Jul 2014	1,000.00
Check	08/25/2014	10546 Accounts Payable		South Suburban Major Crimes Task Force	100.00
	Invoice		Date	Description	Amount
	14-08-12		08/12/2014	8/25/14 golf outing hole sponsorship sign	100.00
Check	08/25/2014	10547 Accounts Payable		Southwest Digital Printing, Inc.	31.98
	Invoice		Date	Description	Amount
	8-084mr		08/07/2014	Aug 2014 plotter maintenance	31.98
Check	08/25/2014	10548 Accounts Payable		Spex Criminalistics	68.38
	Invoice		Date	Description	Amount
	1030		07/30/2014	safety supplies	68.38
Check	08/25/2014	10549 Accounts Payable		Stoller International	29.02
	Invoice		Date	Description	Amount
	P08512		07/18/2014	parts	29.02
Check	08/25/2014	10550 Accounts Payable		Surefire Auto Parts	27.80

Lemont, IL
Warrant list

Bank Account: FM-Clearing - Accounts Payable

Batch Date: 08/25/2014

Type	Date	Number Source	Payee Name	EFT Bank/Account	Transaction Amount
	Invoice		Date	Description	Amount
	363722		07/21/2014	7590 - vehicle supplies	27.80
Check	08/25/2014	10551 Accounts Payable	T.P.I. Building Code Consultants, Inc.		12,011.89
	Invoice		Date	Description	Amount
	7129		08/01/2014	Jul 2014 reviews & inspections	12,011.89
Check	08/25/2014	10552 Accounts Payable	The Municipal Clerks of Illinois		90.00
	Invoice		Date	Description	Amount
	14-08-18		08/18/2014	2014-2015 membership dues	90.00
Check	08/25/2014	10553 Accounts Payable	TKB Associates, Inc		35,832.00
	Invoice		Date	Description	Amount
	10993		08/07/2014	P.D.	35,832.00
Check	08/25/2014	10554 Accounts Payable	Toshiba Financial Services		377.76
	Invoice		Date	Description	Amount
	60943402		06/29/2014	90136046440 - p.w. copier lease	377.76
Check	08/25/2014	10555 Accounts Payable	Total Parking Solutions Inc.		18,990.00
	Invoice		Date	Description	Amount
	102690		08/04/2014	50% deposit - parking machines	18,990.00
Check	08/25/2014	10556 Accounts Payable	Verizon Wireless		109.96
	Invoice		Date	Description	Amount
	9729747845		08/03/2014	685282853-00001	109.96
Check	08/25/2014	10557 Accounts Payable	Warehouse Direct Workplace Solutions		258.69
	Invoice		Date	Description	Amount
	2399536-0		08/05/2014	supplies	188.10
	2405092-0		08/08/2014	supplies	70.59
Check	08/25/2014	10558 Accounts Payable	Water Resources Inc.		1,816.02
	Invoice		Date	Description	Amount
	28924		08/05/2014	10 meters	1,816.02
Check	08/25/2014	10559 Accounts Payable	Koehlinger , Erin M		140.00

Lemont, IL
Warrant list

Bank Account: FM-Clearing - Accounts Payable

Batch Date: 08/25/2014

Type	Date	Number Source	Payee Name	EFT Bank/Account	Transaction Amount
	Invoice		Date	Description	Amount
	12-11-06.		08/14/2014	artwork commission - replaces check #5990	140.00
Check	08/25/2014	10560 Accounts Payable	Ballard , Thomas		53.86
	Invoice		Date	Description	Amount
	14-08-14		08/14/2014	reimbursement - Jewel meeting food, Dupage OEM luncheon	28.98
	14-08-14(2)		08/14/2014	reimbursement - Amazon.com - power cord	24.88
Check	08/25/2014	10561 Accounts Payable	Government Finance Officers Association		280.00
	Invoice		Date	Description	Amount
	14-08-20		08/20/2014	budget award application	280.00
Check	08/25/2014	10562 Accounts Payable	Lemont Police Benevolent Association		800.00
	Invoice		Date	Description	Amount
	14-08-15		08/15/2014	10/2/14 golf outing	800.00
Check	08/25/2014	10563 Accounts Payable	Lemont Police Department		823.00
	Invoice		Date	Description	Amount
	14-08-14		08/14/2014	CI investigation funds	823.00
Check	08/25/2014	10564 Accounts Payable	Walker , John		100.00
	Invoice		Date	Description	Amount
	201412		08/15/2014	Judge-9/7/14-4th Anniversary Exhibit-Lemont Center for the Arts	100.00
Check	08/25/2014	10565 Accounts Payable	Ahlberg , Scott		10,000.00
	Invoice		Date	Description	Amount
	130140(L)		08/13/2014	refund landscape bond - 550 First St	10,000.00
Check	08/25/2014	10566 Accounts Payable	Ahlberg , Scott		500.00
	Invoice		Date	Description	Amount
	130140(T)		08/13/2014	refund Temo CO bond - 550 First St	500.00
Check	08/25/2014	10567 Accounts Payable	Gilkey Window Company		1,000.00
	Invoice		Date	Description	Amount
	14-08-15		08/06/2014	refund Clean-up Bond - 1172 Covington Dr	1,000.00
Check	08/25/2014	10568 Accounts Payable	Martinez , Miguel		1,000.00

Lemont, IL
Warrant list

Bank Account: FM-Clearing - Accounts Payable
 Batch Date: 08/25/2014

Type	Date	Number Source	Payee Name	EFT Bank/Account	Transaction Amount
	Invoice		Date	Description	Amount
	2013-00010607		08/18/2014	refund clean-up bond - 12993 Rolling Meadows Dr	1,000.00
Check	08/25/2014	10569 Accounts Payable	Matilla , Roger		500.00
	Invoice		Date	Description	Amount
	14-08-15		08/06/2014	Refund - tow reimbursement - incident #381404710	500.00
Check	08/25/2014	10570 Accounts Payable	Stanwyck , D. Brett		50.00
	Invoice		Date	Description	Amount
	14-08-06		08/06/2014	reimbursement for citation - PC-014544	50.00
Check	08/25/2014	10571 Accounts Payable	Vitauskas , Algirdas		50.81
	Invoice		Date	Description	Amount
	11-06-14 (orig)		08/11/2014	re-issue 2011 water bill refund check # 65172	50.81
FM-Clearing Accounts Payable Totals:			Transactions: 102		\$631,307.90
	Checks:	102	\$631,307.90		

Payment Register

From Payment Date: 8/29/2014 - To Payment Date: 8/29/2014

Number	Date	Status	Void Reason	Reconciled/ Voided Date	Source	Payee Name	Transaction Amount	Reconciled Amount	Difference
FM-Clearing - Accounts Payable									
EFT									
106	08/29/2014	Open			Accounts Payable	Illinois Municipal Retirement Fund	\$36,772.15		
	Invoice		Date	Description		Amount			
	2015-00000441		08/29/2014	IMRF 1 - IMRF Tier 1*		\$36,772.15			
Type EFT Totals:						1 Transactions	\$36,772.15		
FM-Clearing - Accounts Payable Totals									

EFTs	Status	Count	Transaction Amount	Reconciled Amount
	Open	1	\$36,772.15	\$0.00
	Reconciled	0	\$0.00	\$0.00
	Voided	0	\$0.00	\$0.00
	Total	1	\$36,772.15	\$0.00

All	Status	Count	Transaction Amount	Reconciled Amount
	Open	1	\$36,772.15	\$0.00
	Reconciled	0	\$0.00	\$0.00
	Voided	0	\$0.00	\$0.00
	Stopped	0	\$0.00	\$0.00
	Total	1	\$36,772.15	\$0.00

Grand Totals:

EFTs	Status	Count	Transaction Amount	Reconciled Amount
	Open	1	\$36,772.15	\$0.00
	Reconciled	0	\$0.00	\$0.00
	Voided	0	\$0.00	\$0.00
	Total	1	\$36,772.15	\$0.00

All	Status	Count	Transaction Amount	Reconciled Amount
	Open	1	\$36,772.15	\$0.00
	Reconciled	0	\$0.00	\$0.00
	Voided	0	\$0.00	\$0.00
	Stopped	0	\$0.00	\$0.00
	Total	1	\$36,772.15	\$0.00

Lemont, IL
Warrant list

Bank Account: FM-Clearing - Accounts Payable

Batch Date: 09/08/2014

Type	Date	Number Source	Payee Name	EFT Bank/Account	Transaction Amount
Bank Account: FM-Clearing - Accounts Payable					
Check	09/08/2014	10576 Accounts Payable	Addison Concrete, Inc.		85,825.05
	Invoice	Date	Description		Amount
		13268-3SF	08/28/2014	2014 CDBG sidewalk replacement	85,825.05
Check	09/08/2014	10577 Accounts Payable	Airgas USA, LLC		20.80
	Invoice	Date	Description		Amount
		9920663519	07/31/2014	welding tank rental	20.80
Check	09/08/2014	10578 Accounts Payable	Amalgamated Bank of Chicago		515.00
	Invoice	Date	Description		Amount
		14-08-01 4009	09/01/2014	Series 2012C #4009 bond fees	515.00
Check	09/08/2014	10579 Accounts Payable	AT&T Illinois		1,346.31
	Invoice	Date	Description		Amount
		63024304480814	08/13/2014	630 243-0448 146 1 chestnut crossing l/s	70.63
		63024304590814	08/13/2014	630 243-0459 681 3 oak tree l/s	79.00
		63024373750814	08/13/2014	630 243-7375 749 4 art & culture commission	101.54
		63024317390814	08/13/2014	630 243-1739 155 8 well #6	158.63
		63024312300814	08/13/2014	630 243-1230 805 2 eagle ridge l/s	74.98
		63024314680814	08/13/2014	630 243-1468 926 9 parking garage	147.60
		63024316090814	08/13/2014	630 243-1609 403 9 kohls-target l/s	61.96
		63025719820814	08/25/2014	630 257-1982 589 2 ruffled fthrs l/s	77.54
		63025704360814	08/25/2014	630 257-0436 056 6 glens of connemara l/s	73.76
		63025722900814	08/25/2014	630 257-2290 820 6 well #3	132.69
		63025795390814	08/25/2014	630 257-9539 074 6 keepataw trails l/s	74.24
		63025724740814	08/25/2014	630 257-2474 474 0 p.d. phone line	199.00
		63025752720814	08/25/2014	630 257-5272 181 8 metra station	94.74
Check	09/08/2014	10580 Accounts Payable	AT&T Illinois		13.66
	Invoice	Date	Description		Amount
		14-08-8587	08/16/2014	134648587 - Village Hall internet	13.66
Check	09/08/2014	10581 Accounts Payable	Avalon Petroleum Company		5,608.75
	Invoice	Date	Description		Amount
		453525	08/12/2014	1750 gals unl fuel	5,608.75

Lemont, IL
Warrant list

Bank Account: FM-Clearing - Accounts Payable

Batch Date: 09/08/2014

Type	Date	Number Source	Payee Name	EFT Bank/Account	Transaction Amount
Check	09/08/2014	10582 Accounts Payable	Avaya Financial Services		918.81
	Invoice	Date	Description		Amount
	25721309	09/01/2014	753-1285532-003 - phone system lease payment		918.81
Check	09/08/2014	10583 Accounts Payable	Award Emblem Mfg. Co., Inc.		84.60
	Invoice	Date	Description		Amount
	385264	08/18/2014	awards		7.20
	385572	08/18/2014	awards		77.40
Check	09/08/2014	10584 Accounts Payable	Azavar Audit Solutions		2,219.12
	Invoice	Date	Description		Amount
	10343	09/01/2014	Sep 2014 utility audit contingency pmt		2,219.12
Check	09/08/2014	10585 Accounts Payable	Ballard , Thomas		35.28
	Invoice	Date	Description		Amount
	14-08-27	08/27/2014	reimbursement - UPS store-weather station shipping		35.28
Check	09/08/2014	10586 Accounts Payable	Battery Service Corp.		210.30
	Invoice	Date	Description		Amount
	249664	08/14/2014	speed cart battery		141.90
	249909	08/21/2014	batteries		68.40
Check	09/08/2014	10587 Accounts Payable	Carey C. Cosentino, PC		2,000.00
	Invoice	Date	Description		Amount
	14-09-01	09/01/2014	Aug 2014 legal		2,000.00
Check	09/08/2014	10588 Accounts Payable	Checkpoint Press Inc		397.00
	Invoice	Date	Description		Amount
	31048	08/21/2014	police officer recruitment listing		397.00
Check	09/08/2014	10589 Accounts Payable	Chicago Materials Corp.		1,516.74
	Invoice	Date	Description		Amount
	93266MB	08/07/2014	paved alley blacktop		1,516.74
Check	09/08/2014	10590 Accounts Payable	Chicago Parts Sound, LLC		299.00
	Invoice	Date	Description		Amount
	612251	08/11/2014	repair		299.00

Lemont, IL
Warrant list

Bank Account: FM-Clearing - Accounts Payable

Batch Date: 09/08/2014

Type	Date	Number Source	Payee Name	EFT Bank/Account	Transaction Amount
Check	09/08/2014	10591 Accounts Payable	Chief Supply/Law Enforcement Supply		28.39
	Invoice	Date	Description		Amount
		103428	08/12/2014	supplies - TSO	22.42
		106366	08/18/2014	uniforms - TSO	5.97
Check	09/08/2014	10592 Accounts Payable	Cintas Corporation		254.51
	Invoice	Date	Description		Amount
		8401402222	08/15/2014	document shredding	177.15
		8401417676	08/22/2014	v.h. shredding	77.36
Check	09/08/2014	10593 Accounts Payable	Circle Tractor		105.41
	Invoice	Date	Description		Amount
		01-161084	08/12/2014	parts	105.41
Check	09/08/2014	10594 Accounts Payable	Comcast Cable		206.20
	Invoice	Date	Description		Amount
		14-08-8896	08/22/2014	8771 20 147 0138896 p.w. cable/internet	206.20
Check	09/08/2014	10595 Accounts Payable	ComEd		4,593.10
	Invoice	Date	Description		Amount
		14-08-0229	08/14/2014	0171030229 - street lights - athen knoll	21.17
		14-08-2027	08/16/2014	6235062027 - street lights - rolling mdw dr	4,330.93
		14-08-8014	08/25/2014	3909078014 - street lights - illinois, e of stephen	15.41
		14-08-0007	08/25/2014	1173160007 - street lights - talcott, e of stephen	176.37
		14-08-4052	08/25/2014	2163104052 - street lights - stephen st 1 S river	49.22
Check	09/08/2014	10596 Accounts Payable	Cook County Department of Public Health		180.00
	Invoice	Date	Description		Amount
		14-08-15	08/15/2014	Apr-Jun 2014 health inspections	180.00
Check	09/08/2014	10597 Accounts Payable	Cook County Recorder of Deeds		549.25
	Invoice	Date	Description		Amount
		14-08-22	08/22/2014	recording fees for 13 waivers	549.25
Check	09/08/2014	10598 Accounts Payable	Cook County Treasurer		215.87
	Invoice	Date	Description		Amount

Lemont, IL
Warrant list

Bank Account: FM-Clearing - Accounts Payable

Batch Date: 09/08/2014

Type	Date	Number Source	Payee Name	EFT Bank/Account	Transaction Amount
	14-08-01.		08/01/2014	22-14-401-029-0000 - 2013 2nd installment-10970 Archer Ave	215.87
Check	09/08/2014	10599 Accounts Payable	De Lage Landen Public Finance		602.00
	Invoice		Date	Description	Amount
	42216712		07/28/2014	629642 - Canon copier leases - Aug-Sep	602.00
Check	09/08/2014	10600 Accounts Payable	Dustcatchers, Inc.		38.88
	Invoice		Date	Description	Amount
	86317		08/21/2014	2055 - v.h. carpet mat service	38.88
Check	09/08/2014	10601 Accounts Payable	FedEx		57.49
	Invoice		Date	Description	Amount
	2-754-41568		08/20/2014	shipping	57.49
Check	09/08/2014	10602 Accounts Payable	Guaranteed Technical Services And Consulting, Inc.		3,852.50
	Invoice		Date	Description	Amount
	2012087		08/26/2014	I.T. Support	3,852.50
Check	09/08/2014	10603 Accounts Payable	Homer Tree Care, Inc.		47,765.00
	Invoice		Date	Description	Amount
	14373		08/27/2014	ash tree removal	47,765.00
Check	09/08/2014	10604 Accounts Payable	Illinois Municipal League		20.00
	Invoice		Date	Description	Amount
	0024384-IN		07/25/2014	Ad for Police Chief Opening	20.00
Check	09/08/2014	10605 Accounts Payable	IPELRA		375.00
	Invoice		Date	Description	Amount
	14-08-27		08/27/2014	2014 annual conference - HR	375.00
Check	09/08/2014	10606 Accounts Payable	James D. Fiala Asphalt Corporation		118.16
	Invoice		Date	Description	Amount
	10650MB		08/14/2014	Blacktop	118.16
Check	09/08/2014	10607 Accounts Payable	Johnson, Depp & Quisenberry, PSC		1,239.00
	Invoice		Date	Description	Amount

Lemont, IL
Warrant list

Bank Account: FM-Clearing - Accounts Payable

Batch Date: 09/08/2014

Type	Date	Number Source	Payee Name	EFT Bank/Account	Transaction Amount
	14-08-06		08/28/2014	July 2014 OAN Consulting	588.00
	14-08-06 (b)		08/06/2014	Brownfield grant consulting	651.00
Check	09/08/2014	10608 Accounts Payable	Kelbus , Susan		541.87
	Invoice		Date	Description	Amount
	14-08-06		09/03/2014	2013 property tax rebate	541.87
Check	09/08/2014	10609 Accounts Payable	LEAF		954.49
	Invoice		Date	Description	Amount
	5197553		08/21/2014	100-2580918-002 p.d., p.w. copier lease payment	676.51
	5197552		08/21/2014	100-2580918-001 p.d. imageRunner	277.98
Check	09/08/2014	10610 Accounts Payable	Lemont Park Foundation		600.00
	Invoice		Date	Description	Amount
	14-08-27		08/27/2014	2014 golf outing	600.00
Check	09/08/2014	10611 Accounts Payable	M & M Auto Glass & Upholstery Service		275.00
	Invoice		Date	Description	Amount
	481488		08/29/2014	replace windshield - PD 11-3	275.00
Check	09/08/2014	10612 Accounts Payable	Macke Water Systems, Inc.		282.85
	Invoice		Date	Description	Amount
	942483		07/15/2014	146998 - Lease ID:63885 - water cooler rental agreement	159.80
	952386		08/28/2014	146998 - coffee service supplies	54.90
	944172		07/25/2014	146998 - coffee service supplies	68.15
Check	09/08/2014	10613 Accounts Payable	McKeithan , Mack and Sherry		350.00
	Invoice		Date	Description	Amount
	20140725		07/25/2014	Kops n Kidz DJ	350.00
Check	09/08/2014	10614 Accounts Payable	McMaster-Carr Supply Co.		281.40
	Invoice		Date	Description	Amount
	98196845		08/13/2014	Soap Dispenser	107.15
	98991805		08/20/2014	Supplies	174.25
Check	09/08/2014	10615 Accounts Payable	Menards		468.87
	Invoice		Date	Description	Amount

Lemont, IL
Warrant list

Bank Account: FM-Clearing - Accounts Payable

Batch Date: 09/08/2014

Type	Date	Number Source	Payee Name	EFT Bank/Account	Transaction Amount
	48233		08/21/2014	Supplies	104.60
	48162		08/20/2014	Supplies	364.27
Check	09/08/2014	10616 Accounts Payable	Napa Auto Parts		437.30
	Invoice		Date	Description	Amount
	544189		08/19/2014	parts	249.56
	544188		08/19/2014	parts	163.04
	544323		08/20/2014	parts	24.70
Check	09/08/2014	10617 Accounts Payable	NiCor Gas		173.36
	Invoice		Date	Description	Amount
	14/08-0043 0		08/15/2014	69-22-85-0043 0 ruffled fthrs l/s	78.86
	14/08-8700 1		08/19/2014	93-56-54-8700 1 smith farms l/s	23.15
	14/08-9378 5		08/15/2014	25-59-90-9378 5 well #6	23.15
	14/08-9589 2		08/20/2014	37-62-87-9589 2 target-kohls l/s	25.05
	14/08-2000 8 (2)		08/28/2014	37-54-52-2000 8 well #3	23.15
Check	09/08/2014	10618 Accounts Payable	North American Salt Co.		2,242.65
	Invoice		Date	Description	Amount
	71207678		08/20/2014	salt	2,242.65
Check	09/08/2014	10619 Accounts Payable	North East Multi-Regional Training Inc		300.00
	Invoice		Date	Description	Amount
	185490		08/13/2014	training	300.00
Check	09/08/2014	10620 Accounts Payable	NPELRA		299.00
	Invoice		Date	Description	Amount
	14-08-27		08/27/2014	10/26/14 training - HR	299.00
Check	09/08/2014	10621 Accounts Payable	OfficeMax Incorporated		190.98
	Invoice		Date	Description	Amount
	680011		08/21/2014	office supplies	190.98
Check	09/08/2014	10622 Accounts Payable	PDC Laboratories		1,220.00
	Invoice		Date	Description	Amount
	777297		08/15/2014	sample testing	1,220.00
Check	09/08/2014	10623 Accounts Payable	Purchase Power		2,020.99

Lemont, IL
Warrant list

Bank Account: FM-Clearing - Accounts Payable

Batch Date: 09/08/2014

Type	Date	Number Source	Payee Name	EFT Bank/Account	Transaction Amount
	Invoice		Date	Description	Amount
	14-08-20		08/20/2014	postage meter refill	2,020.99
Check	09/08/2014	10624 Accounts Payable	Rag's Electric		2,600.36
	Invoice		Date	Description	Amount
	9563		08/11/2014	street light repair	2,600.36
Check	09/08/2014	10625 Accounts Payable	Razor Image		650.00
	Invoice		Date	Description	Amount
	14-07-11		07/11/2014	signage for Heritage Fest	650.00
Check	09/08/2014	10626 Accounts Payable	Rendels, Inc.		2,685.00
	Invoice		Date	Description	Amount
	169492		08/07/2014	parts	2,685.00
Check	09/08/2014	10627 Accounts Payable	Rod Baker Ford		486.13
	Invoice		Date	Description	Amount
	130206		08/28/2014	parts	372.47
	130176		08/26/2014	parts	98.16
	130208		08/28/2014	parts	15.50
Check	09/08/2014	10628 Accounts Payable	Safety Kleen		213.87
	Invoice		Date	Description	Amount
	64571166		08/14/2014	parts washer service	213.87
Check	09/08/2014	10629 Accounts Payable	ServiceMaster By Bouck		3,850.00
	Invoice		Date	Description	Amount
	5717394		08/23/2014	additional cleaning - Village Hall	3,850.00
Check	09/08/2014	10630 Accounts Payable	Smollen , Charlene		14.78
	Invoice		Date	Description	Amount
	14-08-27		08/27/2014	reimbursement - MCI conference meal	14.78
Check	09/08/2014	10631 Accounts Payable	Southwest Central Dispatch		25,431.99
	Invoice		Date	Description	Amount
	14-08-20		08/20/2014	10-1201-513 - Sep 2014 assessment	25,431.99
Check	09/08/2014	10632 Accounts Payable	Surefire Auto Parts		590.30

Lemont, IL
Warrant list

Bank Account: FM-Clearing - Accounts Payable

Batch Date: 09/08/2014

Type	Date	Number Source	Payee Name	EFT Bank/Account	Transaction Amount
	Invoice		Date	Description	Amount
	366955		08/12/2014	parts	230.72
	367056		08/13/2014	parts	32.92
	367782		08/18/2014	parts	46.82
	367776		08/18/2014	parts	13.01
	368000		08/19/2014	parts	44.28
	368224		08/20/2014	parts	13.14
	368367		08/21/2014	parts	42.42
	368430		08/21/2014	parts	91.99
	368519		08/22/2014	parts	8.98
	369025		08/26/2014	parts	3.99
	369619		08/29/2014	supplies	37.32
	366913		08/12/2014	parts	24.71
Check	09/08/2014	10633 Accounts Payable		Terminal Supply Co.	189.36
	Invoice		Date	Description	Amount
	44141-00		08/11/2014	supplies	189.36
Check	09/08/2014	10634 Accounts Payable		Theodore Polygraph Service	135.00
	Invoice		Date	Description	Amount
	4429		08/20/2014	police testing	135.00
Check	09/08/2014	10635 Accounts Payable		Trafftech Inc.	1,350.00
	Invoice		Date	Description	Amount
	1046		08/19/2014	sign machine maintenance agreement	1,350.00
Check	09/08/2014	10636 Accounts Payable		Tressler, LLP	14,488.00
	Invoice		Date	Description	Amount
	345435		08/07/2014	Jul 2014 legal services	8,600.00
	345436		08/07/2014	Jul 2014 legal services	5,188.00
	345439		08/07/2014	Jul 2014 legal services	700.00
Check	09/08/2014	10637 Accounts Payable		Unifirst Corporation	54.45
	Invoice		Date	Description	Amount
	062 0086146		08/25/2014	shop towel service	54.45
Check	09/08/2014	10638 Accounts Payable		V & N Concrete Products, Inc.	299.52

Lemont, IL
Warrant list

Bank Account: FM-Clearing - Accounts Payable

Batch Date: 09/08/2014

Type	Date	Number Source	Payee Name	EFT Bank/Account	Transaction Amount
	Invoice		Date	Description	Amount
	27740		08/20/2014	supplies	299.52
Check	09/08/2014	10639 Accounts Payable	Vision Service Plan		930.92
	Invoice		Date	Description	Amount
	14-08-19		08/19/2014	Sep 2014 vision insurance premiums	930.92
Check	09/08/2014	10640 Accounts Payable	Warehouse Direct Workplace Solutions		307.80
	Invoice		Date	Description	Amount
	2414675-0		08/19/2014	supplies	169.80
	2411461-0		08/15/2014	supplies	118.76
	2415537-0		08/20/2014	supplies	19.24
Check	09/08/2014	10641 Accounts Payable	Water Resources Inc.		3,181.90
	Invoice		Date	Description	Amount
	28939		08/11/2014	1 water meter	1,499.94
	28941		08/12/2014	6 water meters	1,681.96
Check	09/08/2014	10642 Accounts Payable	Woodglen Development, LLC		1,000.00
	Invoice		Date	Description	Amount
	110720		08/27/2014	refund clean-up bond - 821 Woodglen Ln	1,000.00
Check	09/08/2014	10643 Accounts Payable	Zee Medical Inc.		98.70
	Invoice		Date	Description	Amount
	0100183665		08/19/2014	supplies	48.52
	0100183664		08/19/2014	first aid supplies	50.18
Check	09/08/2014	10644 Accounts Payable	Filotto Construction		1,000.00
	Invoice		Date	Description	Amount
	2014-000000564		08/20/2014	refund Clean Up Bond - 12940 Bell Rd	1,000.00
Check	09/08/2014	10645 Accounts Payable	Freeman , Corina		65.00
	Invoice		Date	Description	Amount
	14-08-28		08/25/2014	Refund Metra Permit #0411, 0591	65.00
Check	09/08/2014	10646 Accounts Payable	Garcia , Michael		2.00
	Invoice		Date	Description	Amount

Lemont, IL
Warrant list

Bank Account: FM-Clearing - Accounts Payable

Batch Date: 09/08/2014

Type	Date	Number Source	Payee Name	EFT Bank/Account	Transaction Amount
	13-07-19.		08/28/2014	replaces refund ck#6804 for overpmt on ticket #PC-012790	2.00
Check	09/08/2014	10647 Accounts Payable	Great Lakes Roofing & Construction		1,000.00
	Invoice		Date	Description	Amount
	2014-00000509		08/28/2014	refund clean-up bond - 1270 Franciscan Dr, Lemont, IL	1,000.00
Check	09/08/2014	10648 Accounts Payable	Inspired by Design		1,000.00
	Invoice		Date	Description	Amount
	2013-00010777		08/28/2014	refund clean-up bond - 12812 Dunmoor Dr, Lemont, IL	1,000.00
Check	09/08/2014	10649 Accounts Payable	MSP Construction		1,000.00
	Invoice		Date	Description	Amount
	2014-00000065		08/29/2014	refund clean-up bond - 1213 Prairie Ln, Lemont, IL	1,000.00
Check	09/08/2014	10650 Accounts Payable	Provencal Construction		1,000.00
	Invoice		Date	Description	Amount
	120323		08/20/2014	refund clean up bond - 44 Sawgrass Dr	1,000.00
FM-Clearing Accounts Payable Totals:			Transactions: 75		\$235,475.02
Checks:	75	\$235,475.02			

Village Board

Agenda Memorandum

To: Mayor & Village Board

From: Linda Molitor

Subject: Amendment to Liquor Code (C-3 Classification)

Date: September 4, 2014

SUMMARY

Otto Brandt Wines, Inc., has previously applied and been granted a C-3 Liquor License. They have expanded their area to include a seating area and to sell wine by the glass on premise in addition to the on premise wine tasting. To accommodate this change, the language of the C-3 classification needs to be amended to include that the on-premises consumption shall not exceed more than twenty-five percent of the total retail sales of the establishment.

BOARD ACTION

Vote on the attached ordinance.

ATTACHMENTS (IF APPLICABLE)

An ordinance amending Lemont Municipal Code: Liquor Licenses (Class C-3).

**VILLAGE OF LEMONT
ORDINANCE NO. _____**

**AN ORDINANCE
AMENDING LEMONT MUNICIPAL CODE: LIQUOR LICENSES
(CLASS C-3 LICENSES)**

**ADOPTED BY THE
PRESIDENT AND THE BOARD OF TRUSTEES
OF THE VILLAGE OF LEMONT
THIS 8th DAY OF SEPTEMBER, 2014**

**Published in pamphlet form by
Authority of the President and
Board of Trustees of the Village of
Lemont, Counties of Cook, Will and
DuPage, Illinois, this 8th day of September, 2014.**

ORDINANCE NO. _____

**AN ORDINANCE
AMENDING LEMONT MUNICIPAL CODE: LIQUOR LICENSES
(CLASS C-3 LICENSES)**

WHEREAS, the Village of Lemont (“Village”) is an Illinois Municipal Corporation pursuant to the Illinois Constitution of 1970 and the Statutes of the State of Illinois; and,

WHEREAS, Otto Brandt Wines, Inc., operating at 110 Main Street, Lemont, IL, has previously applied for and been granted a Class C-3 Liquor License and has further requested the Village adopt an ordinance amending the Lemont Municipal Code, as amended, so as to permit a change to said classification; and

WHEREAS, the President and Board of Trustees of the Village of Lemont desire to amend the classification of the Class C-3 liquor licenses.

NOW, THEREFORE, BE IT ORDAINED BY THE PRESIDENT AND BOARD OF TRUSTEES of the Village of Lemont, Illinois:

SECTION 1: The above recitals are incorporated in this ordinance as if fully set forth.

SECTION 2: The Lemont Municipal Code, Title 5: Business Licenses and Regulations, Chapter 5.04, Liquor Licenses, Subsection 5.04.060A, Classes of Licenses, Number of Licenses and License Fees, is hereby amended to read as follow in the manner and form shown in strikethrough type below and inserting therein and therefore such new text in the manner and form and shown in underlined bold type below, so that said Section 5.04.060A shall hereafter provide as follows:

14. Class C-3.

Class C-3 licenses shall authorize the retail sale of alcohol if the principal business is the primary sale of alcohol off premises by mail or phone order with display room **and on-premises consumption shall not exceed more than twenty-five percent of the total retail sales of the establishment** ~~periodic~~

~~consumption on premises.~~ Hours of operation for consumption or sale on premises shall be from nine a.m. to ten p.m.

SECTION 3: This Ordinance shall be in full force and effect from and after its passage, approval and publication as provided by law.

SECTION 4: All Ordinances or parts of Ordinances in conflict herewith shall be and the same are hereby repealed.

SECTION 5: The Village Clerk of the Village of Lemont shall certify to the adoption of this Ordinance and cause the same to be published in pamphlet form.

PASSED AND APPROVED BY THE PRESIDENT AND BOARD OF TRUSTEES OF THE VILLAGE OF LEMONT, COUNTIES OF COOK, WILL, AND DUPAGE, ILLINOIS, on this 8th day of September, 2014.

PRESIDENT AND VILLAGE BOARD MEMBERS:

	AYES:	NAYS:	ABSENT:	ABSTAIN
Debby Blatzer	_____	_____	_____	_____
Paul Chialdikas	_____	_____	_____	_____
Clifford Miklos	_____	_____	_____	_____
Ron Stapleton	_____	_____	_____	_____
Rick Sniegowski	_____	_____	_____	_____
Jeanette Virgilio	_____	_____	_____	_____

BRIAN K. REAVES
President

ATTEST:

CHARLENE M. SMOLLEN
Village Clerk



Village of Lemont
Planning & Economic Development Department

418 Main Street · Lemont, Illinois 60439
phone 630-257-1595 · fax 630-257-1598

TO: Mayor Reaves
Village Board of Trustees

FROM: Martha M. Glas, Village Planner

THRU Charity Jones, AICP, Planning & Economic Development Director

SUBJECT: Case 14-03 Chicago Blaze Rugby Club PUD

DATE: September 4, 2014

SUMMARY

Walt Rebenson, president of Chicago Blaze Building Corporation, owner of the subject property, is requesting a Final PUD for the redevelopment of the site which includes a new 4,738 sq. ft. rugby clubhouse and associated parking and a 3-car garage for material storage. The redevelopment affects the western 240 ft of the property. No changes are proposed to the eastern portion that comprises the rugby fields. Staff and PZC recommended approval with conditions.

BOARD ACTION

Vote on the attached ordinance.

ATTACHMENTS

An Ordinance Granting A Special Use For A Planned Unit Development (PUD) For Chicago Blaze Rugby Club At 13011 Smith Road In Lemont, Il.

VILLAGE OF LEMONT
ORDINANCE NO. _____

**AN ORDINANCE GRANTING A SPECIAL USE FOR A PLANNED UNIT
DEVELOPMENT (PUD) FOR CHICAGO BLAZE RUGBY CLUB AT 13011 SMITH
ROAD IN LEMONT, IL.**

(13011 Smith Road)

**Adopted by the
President and Board of Trustees
of the Village of Lemont**

This 8th Day of September, 2014

**Published in pamphlet form by
authority of the President and
Board of Trustees of the Village
of Lemont, Cook, DuPage, and Will
Counties, Illinois this 8th day of
September, 2014.**

ORDINANCE NO. _____

AN ORDINANCE GRANTING A SPECIAL USE FOR A PLANNED UNIT DEVELOPMENT (PUD) FOR CHICAGO BLAZE RUGBY CLUB AT 13011 SMITH ROAD IN LEMONT, IL.

(13011 Smith Road)

WHEREAS, Walt Rebenson (hereinafter referred to as the “Petitioner”), is the President of Chicago Blaze Building Corporation and owner of the subject property covering approximately 14.3 acres located at 13011 Smith Road, legally described and depicted in Exhibit A, attached hereto and incorporated herein; and

WHEREAS, the Petitioner made application under the provisions of the Lemont Unified Development Ordinance (“UDO”) for special use for a planned unit development, final PUD approval, for the subject property; and

WHEREAS, the Planning and Zoning Commission of the Village of Lemont, Illinois, in accordance with the UDO, conducted a public hearing on the petition on May 21, 2014 and voted 7-0 to recommend approval of the petitioner’s requests; and

WHEREAS, a notice of the aforesaid Public Hearing was made in the manner provided by law and was published in the *Lemont Reporter-Met*, a newspaper of general circulation within the Village; and

WHEREAS, the President and Board of Trustees of the Village have reviewed the matter herein and have determined that the same is in the best interest of the public health, safety and welfare of the residents of the Village of Lemont, and hereby adopt the finding of facts as set forth in Exhibit B.

NOW, THEREFORE, BE IT ORDAINED BY THE PRESIDENT AND BOARD OF TRUSTEES OF THE VILLAGE OF LEMONT, COUNTIES OF COOK, DUPAGE, AND WILL, ILLINOIS:

SECTION 1: Incorporation of Recitals. The foregoing findings and recitals are hereby adopted as Section 1 of this Ordinance and are incorporated by reference as if set forth verbatim herein.

SECTION 2: Special Use. A special use is granted to Chicago Blaze Building Corporation on the subject property for a planned unit development for a Rugby sports club and associated fields.

SECTION 3: General Conditions. Unless otherwise approved by the Village Board the Subject Property shall be maintained in accordance with Village Code, the approved plans, and the PUD documents that are exhibits to this Ordinance.

SECTION 4: Specific Conditions. The special use for a planned unit development shall have the following conditions:

- A. The clubhouse may be constructed as shown in Exhibit C- Elevations, pages A4-A7, submitted by Schmidt Design, Inc.
- B. A deck for spectator viewing is permitted on the rear of the clubhouse.
- C. The existing picnic shelter is permitted to remain on the property and may be repaired or replaced.
- D. A 38' x 24' accessory structure with doors facing Smith Rd. is permitted for the storage of field equipment and supplies. Building materials, roof material and color palette are to match the clubhouse. This accessory structure may only be erected in the location shown in Exhibit D- Site Plan, submitted by Schmidt Design Inc., or as authorized and approved by the Director of Planning and Economic Development.
- E. The north parking lot is permitted to remain gravel as shown in Exhibit D. Reduced illumination is permitted in the north parking lot as depicted in Exhibit E- Photometric Plan, submitted by Schmidt Design, Inc. Upon the north parking lot being paved, the Petitioner must comply with the applicable UDO parking lot standards for illumination.
- F. A 50% reduction in the required number of plant units is permitted for the exterior (i.e. perimeter) parking lot landscaping. A 50% reduction in the required landscaped area is permitted for the interior parking lot landscaping. So long as the north parking lot remains gravel, no interior parking lot landscaping is required within the gravel lot. Should the north parking be paved, interior parking lot landscaping shall be provided consistent with this section.
- G. A 6' chain link fence is permitted to be located between the proposed buildings and the playing fields.
- H. The public sidewalk along Smith Road may be no less than 5' in width.
- I. As offered by the Petitioner, a Plat of Dedication showing 50' of right of way for future roadway improvements along Smith Rd. shall be submitted to the Village for approval. Once approved by the Village, the Petitioner shall record said Plat prior to the issuance of a site development permit.

SECTION 5: The planned unit development approval shall lapse in the event the Petitioner does not file a complete application for a site development permit within one (1) year of the effective date of this ordinance.

SECTION 6: The Village Clerk of the Village of Lemont be and is directed hereby to publish this Ordinance in pamphlet form, pursuant to the Statutes of the State of Illinois, made and provided.

SECTION 7: This Ordinance shall be in full force and effect from and after its passage, approval and publication provided by law.

PASSED AND APPROVED BY THE PRESIDENT AND BOARD OF TRUSTEES OF THE VILLAGE OF LEMONT, COUNTIES OF COOK, WILL, AND DuPAGE, ILLINOIS, ON THIS 8TH DAY OF SEPTEMBER, 2014.

	<u>AYES</u>	<u>NAYS</u>	<u>ABSENT</u>	<u>ABSTAIN</u>
Debby Blatzer				
Paul Chialdikas				
Clifford Miklos				
Ron Stapleton				
Rick Sniegowski				
Jeanette Virgilio				

**Approved by me this 8th day of September,
2014**

BRIAN K. REAVES, Village President

Attest:

CHARLENE M. SMOLLEN, Village Clerk

ALTA/ACSM LAND TITLE SURVEY

EXHIBIT A

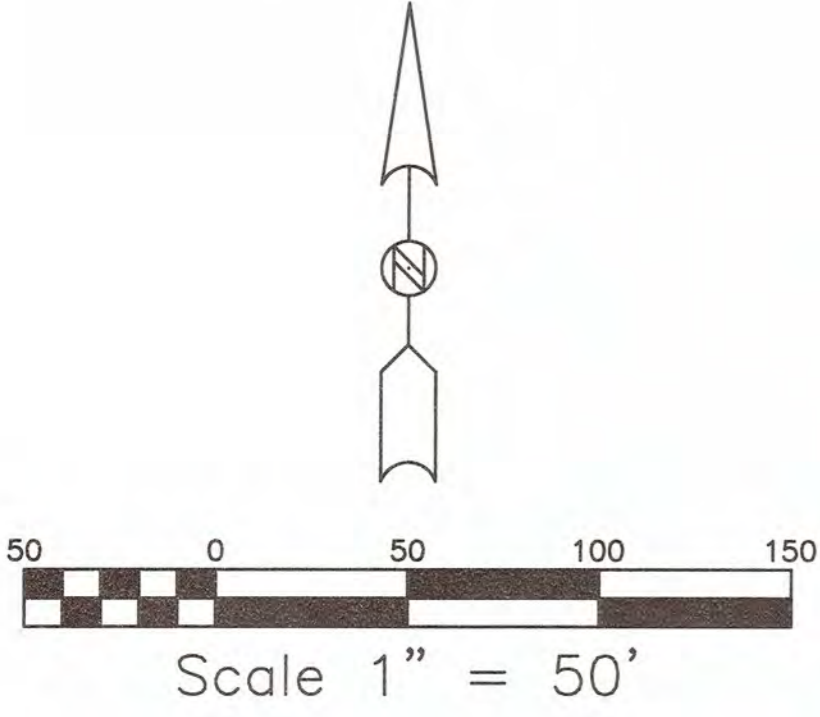

LEGAL DESCRIPTIONS

PARCEL 1:
 THE NORTH 240 FEET OF THE WEST 200 FEET OF THE SOUTH 20 ACRES OF THE SOUTH 59 ACRES OF THE WEST HALF OF THE NORTHWEST QUARTER OF SECTION 31, TOWNSHIP 37 NORTH, RANGE 11 EAST OF THE THIRD PRINCIPAL MERIDIAN, IN COOK COUNTY, ILLINOIS.

PARCEL 2:
 THE NORTH 335.39 FEET OF THE SOUTH 20 ACRES (EXCEPT THE NORTH 240 FEET OF THE WEST 200 FEET THEREOF) IN THE WEST HALF OF THE NORTHWEST QUARTER OF SECTION 31, TOWNSHIP 37 NORTH, RANGE 11 EAST OF THE THIRD PRINCIPAL MERIDIAN, IN COOK COUNTY, ILLINOIS.

PARCEL 3:
 THE SOUTH 200 FEET OF THE NORTH 39 ACRES OF THE SOUTH 59 ACRES OF THE WEST HALF OF THE NORTHWEST QUARTER OF SECTION 31, TOWNSHIP 37 NORTH, RANGE 11 EAST OF THE THIRD PRINCIPAL MERIDIAN, IN COOK COUNTY, ILLINOIS.

STATE OF ILLINOIS)
 COUNTY OF WILL)⁹⁹
 TO: CHICAGO BLAZE RUGBY CLUB

THIS IS TO CERTIFY THAT THIS MAP OR PLAT AND THE SURVEY ON WHICH IT IS BASED WERE MADE IN ACCORDANCE WITH THE 2011 MINIMUM STANDARD DETAIL REQUIREMENTS FOR ALTA/ACSM LAND TITLE SURVEYS, JOINTLY ESTABLISHED AND ADOPTED BY ALTA AND NSPS, AND INCLUDES ITEMS 1, 2, 3, 4, 7(a), 8, 9, 11(a) and 22 OF TABLE "A" THEREOF. THE FIELD WORK WAS COMPLETED ON SEPTEMBER 6, 2013.

September 10, 2013
 DATE

ILLINOIS PROFESSIONAL LAND SURVEYOR NO. 3369
 EXPIRATION DATE: 11/30/2014
 GEOTECH INCORPORATED PROFESSIONAL
 DESIGN FIRM NUMBER 184-000165

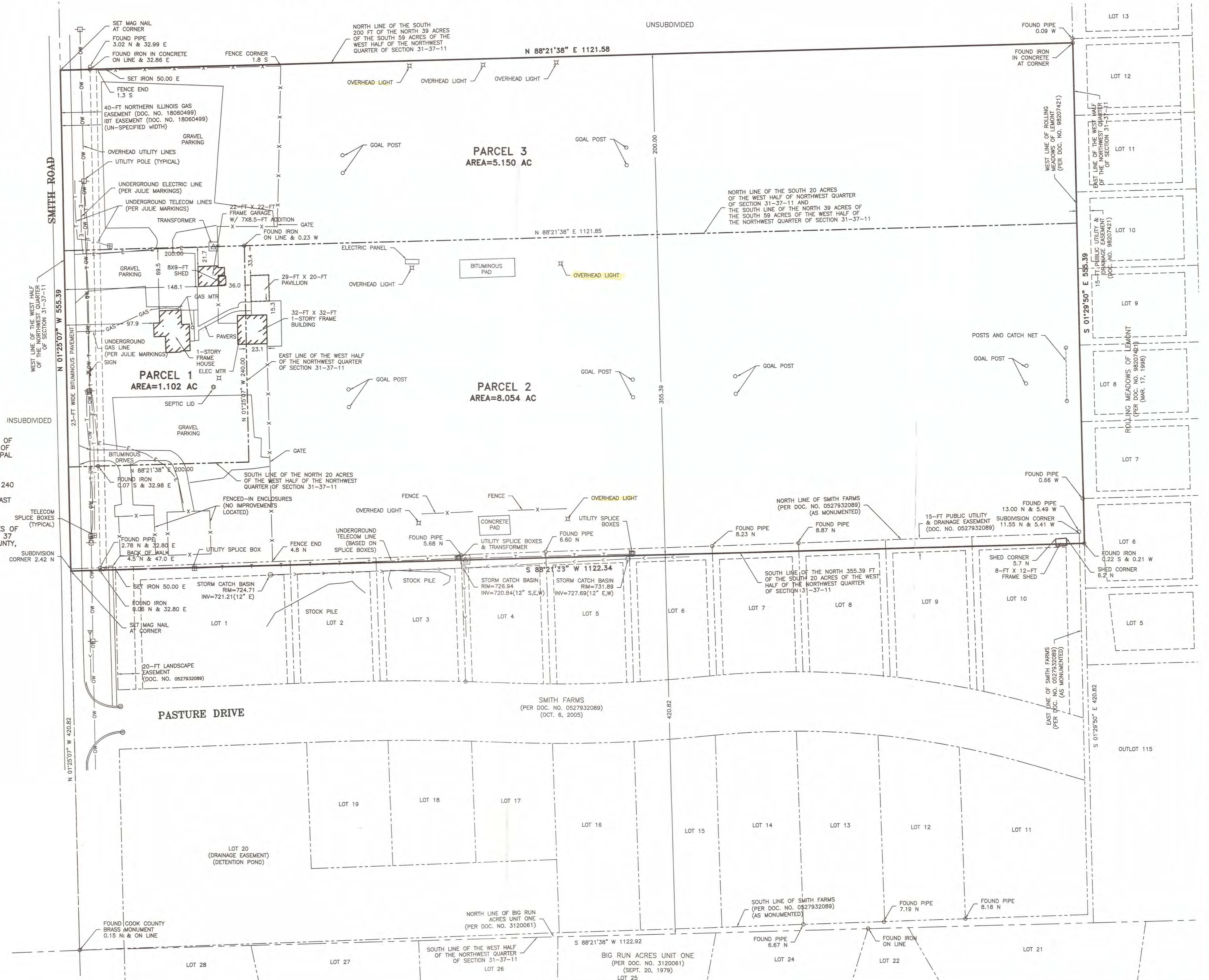

DATE BY REVISION

ORDERED BY: FOREST PRESERVE DISTRICT OF WILL COUNTY
 JOURNAL, ILLINOIS 60433
 DRAWN BY: CJT JOB # GJN1885
 CHECKED BY: CMP DATE: 09/10/2013

PART OF THE NE 1/4 OF SECTION 3-36-10

GEOTECH INC.
 CONSULTING ENGINEERS - LAND SURVEYORS
 1207 CEDARWOOD DRIVE CREST HILL, ILLINOIS 60403 815/730-1010

1
 GJN18587

EXHIBIT B

FINDINGS OF FACT

FINDINGS. Based upon the evidence and testimony presented in the public hearing, the Planning & Zoning Commission finds the following:

1. The Planned Unit Development is consistent with general purpose and intent of the Unified Development Ordinance in that it will not have a negative impact on surrounding properties, or the Village in general.
2. The property has been used for outdoor recreational purposes for over 15 year and is consistent with the draft 2030 Comprehensive Plan update which includes goals of encouraging privately run recreational opportunities.
3. A special use for a PUD to allow for the redevelopment of the site as proposed will enable productive use of the property consistent with its unique use and will ensure the safety of participants and spectators utilizing the site.

EXHIBIT C- Elevations

schmidt DESIGN inc.
 Architecture
 Planning
 Interior Design
 701 CLINTON AVENUE
 OAK PARK, IL 60452
 TEL: 708-321-4300
 FAX: 708-321-4320

Chicago Blaze Building Corporation, Inc.
 13011 W. Smith Road
 Lemont, Illinois 60439



A-4
 WEST
 ELEVATION

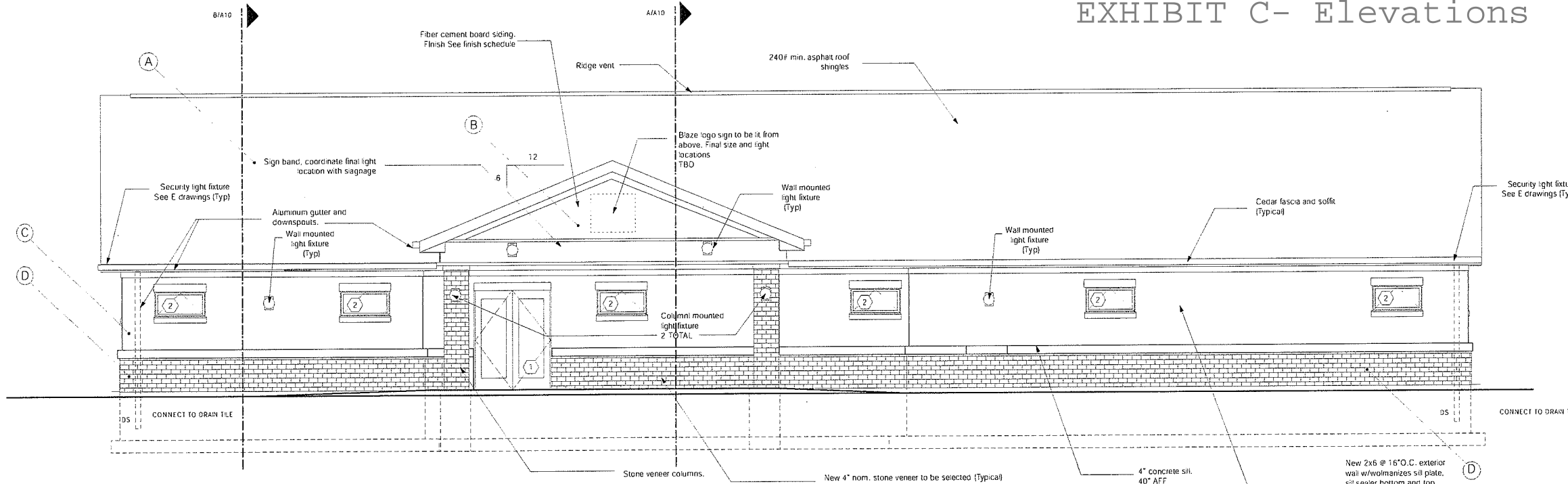

WEST ELEVATION

Scale: 1/4" = 1'-0"

MATERIALS LEGEND

A	ROOFING	CertainTeed - Landmark Series - Pro Max Def Resawn Shake
B	SIDING 1	Portsmouth Shake & Shingles - 8" Staggered Edge shingles - Sand (Fiber Cement Board)
C	SIDING 2	Portsmouth Shake & Shingles - 8" Straight Edge shingles - Wicker (Fiber Cement Board)
D	STONE VENEER	Natural Stone Veneers Int. Inc. - Fieldstone Collection - New England Fieldstone

24x48 AWNING Manufacturer: Jeld-Wen or approved equal
 2448, Vinyl clad Low E glazed skylight U value: 0.31

TYPICAL WINDOW

48x60 SLIDING Manufacturer: Jeld-Wen or approved equal
 48.60 Vinyl clad Low E glazed skylight U value: 0.31

PASS-THRU WINDOW

30x46 SKYLIGHT Manufacturer: Velux or approved equal
 Self flashed fixed skylight SF 3046, Bronze aluminum Triple glazed skylight U value: 0.27

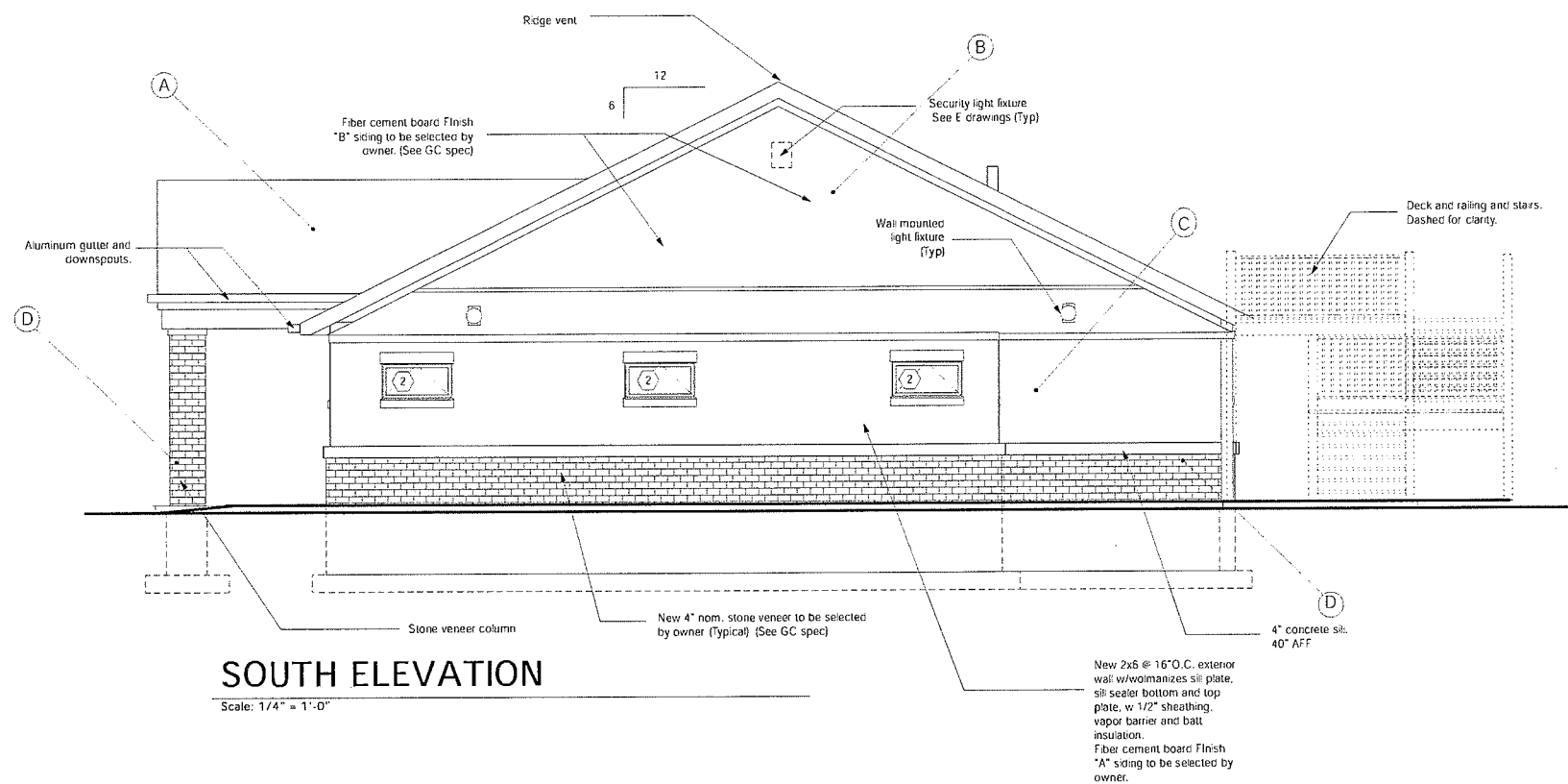

SOUTH ELEVATION

Scale: 1/4" = 1'-0"

MATERIALS LEGEND

A	ROOFING	CertainTeed - Landmark Series -Pro Max Def Resawn Shake
B	SIDING 1	Portsmouth Shake & Shingles - 8" Staggered Edge shingles - Sand (Fiber Cement Board)
C	SIDING 2	Portsmouth Shake & Shingles - 8" Straight Edge shingles - Wicker (Fiber Cement Board)
D	STONE VENEER	Natural Stone Veneers Int. Inc. - Fieldstone Collection - New England Fieldstone

schmidt DESIGN inc.
 Architecture
 Planning
 Interior Design
 101 CLINTON AVENUE
 OAK PARK, IL 60454
 TEL: 708.326.5500
 FAX: 708.326.5500

Chicago Blaze Building Corporation, Inc.
 13011 W. Smith Road
 Lemont, Illinois 60439



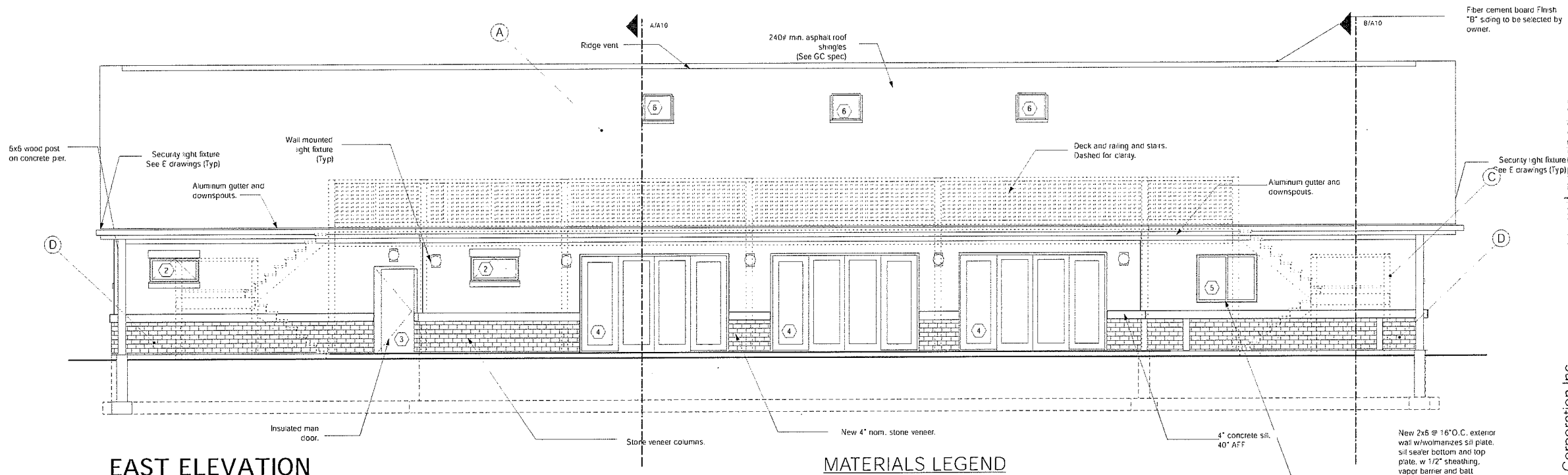

EAST ELEVATION

Scale: 1/4" = 1'-0"

MATERIALS LEGEND

A	ROOFING	CertainTeed - Landmark Series -Pro Max Def Resawn Shake
B	SIDING 1	Portsmouth Shake & Shingles - 8' Staggered Edge shingles - Sand (Fiber Cement Board)
C	SIDING 2	Portsmouth Shake & Shingles - 8' Straight Edge shingles - Wicker (Fiber Cement Board)
D	STONE VENEER	Natural Stone Veneers Int. Inc. - Fieldstone Collection - New England Fieldstone

Fiber cement board Finish "B" siding to be selected by owner.

New 2x6 @ 16" O.C. exterior wall w/walmanizes sill plate, sill sealer bottom and top plate, w 1/2" sheathing, vapor barrier and batt insulation. Fiber cement board Finish "A" siding to be selected by owner.

schmidt DESIGN inc.
 Architecture
 Planning
 Interior Design
 707 CLINTON AVENUE
 ONE PARK L. BLDG
 LEMONT, ILL. 60439
 TEL: 630-261-5404
 FAX: 630-261-5400

Chicago Blaze Building Corporation, Inc.
 13011 W. Smith Road
 Lemont, Illinois 60439

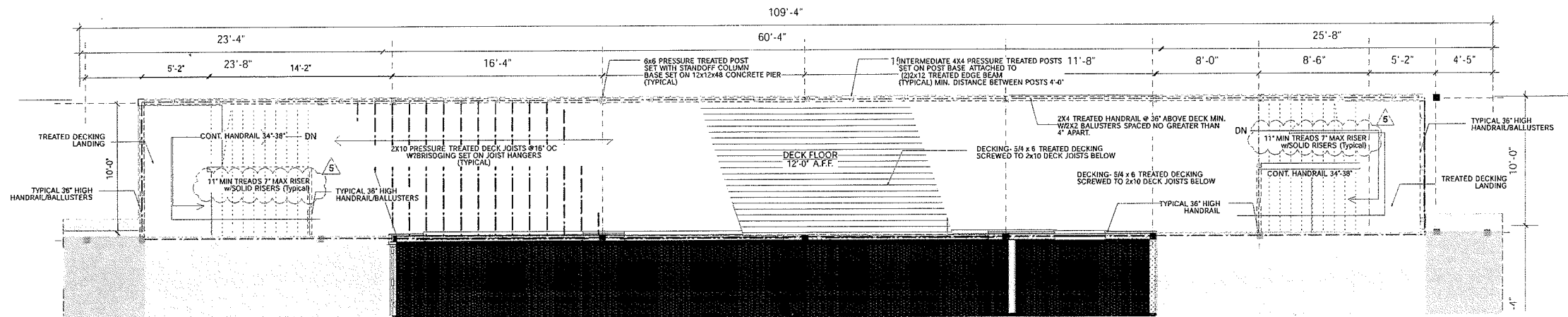

A-6
 EAST
 ELEVATION

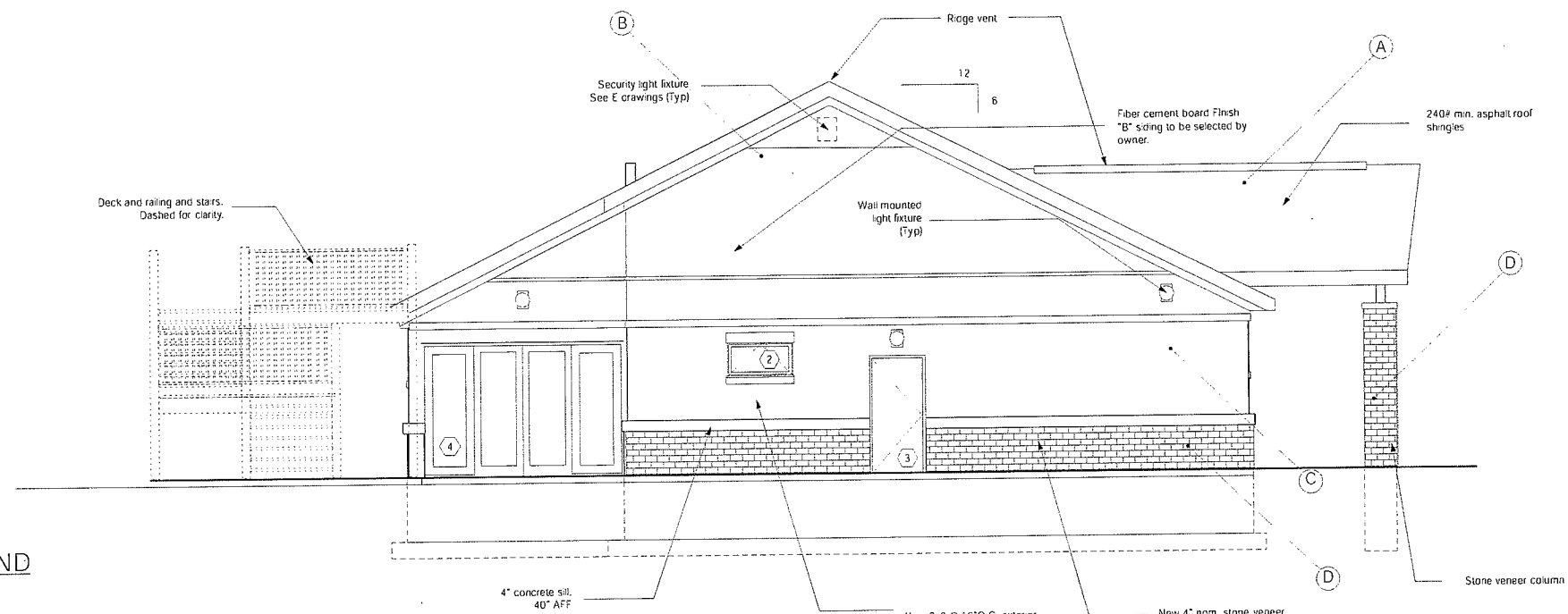

MATERIALS LEGEND

A	ROOFING	CertainTeed - Landmark Series -Pro Max Def Resawn Shake
B	SIDING 1	Portsmouth Shake & Shingles - 8" Staggered Edge shingles - Sand (Fiber Cement Board)
C	SIDING 2	Portsmouth Shake & Shingles - 8" Straight Edge shingles - Wicker (Fiber Cement Board)
D	STONE VENEER	Natural Stone Veneers Int. Inc. - Fieldstone Collection - New England Fieldstone

NORTH ELEVATION

Scale: 1/4" = 1'-0"

schmidt DESIGN inc.
 Architecture
 Planning
 Interior Design
 107 CLINTON AVENUE
 OAK PARK, IL 60454
 TEL: 708-224-4104
 FAX: 708-224-4530

Chicago Blaze Building Corporation, Inc.
 13011 W. Smith Road
 Lemont, Illinois 60439



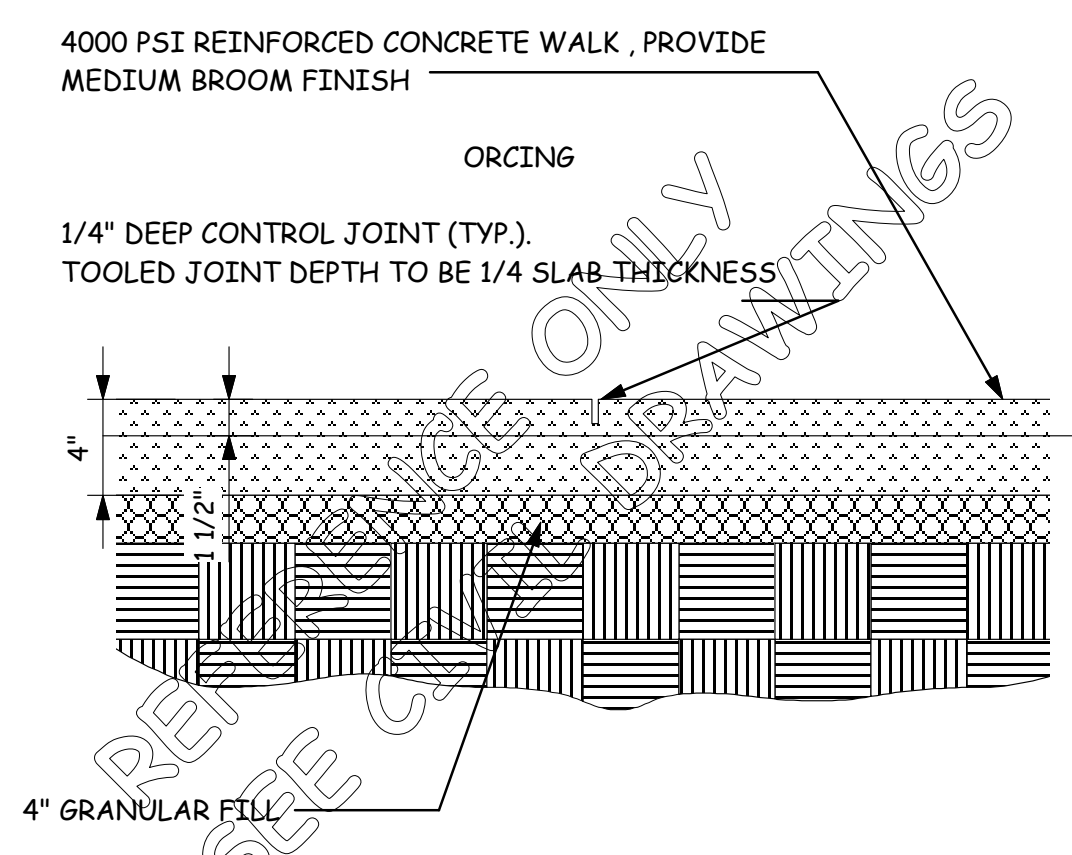

DETAIL-CONTROL JOINT
1-1/2"=1'-0"

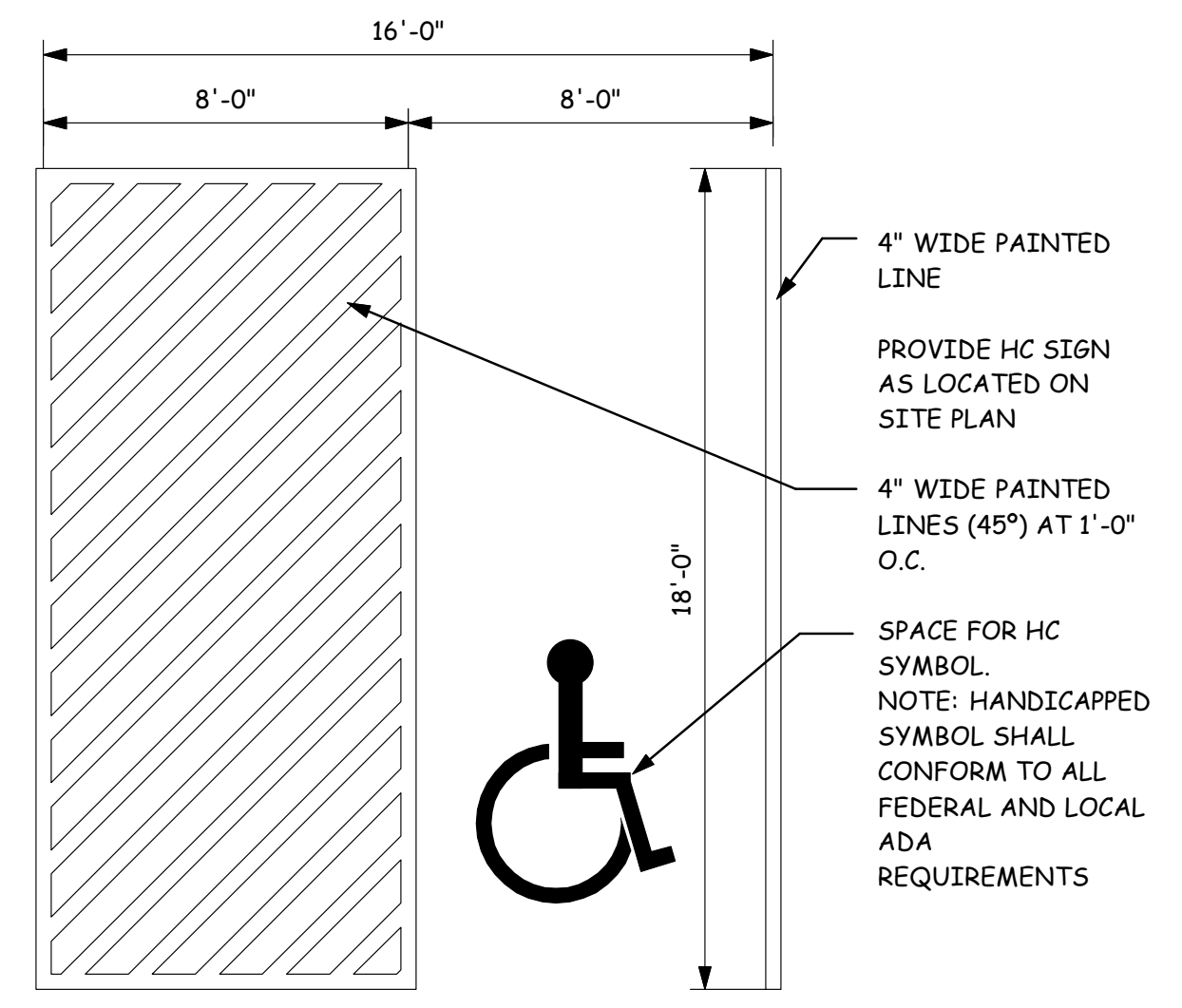

DETAIL-H.C. PARKING STALL
1/4"=1'-0"

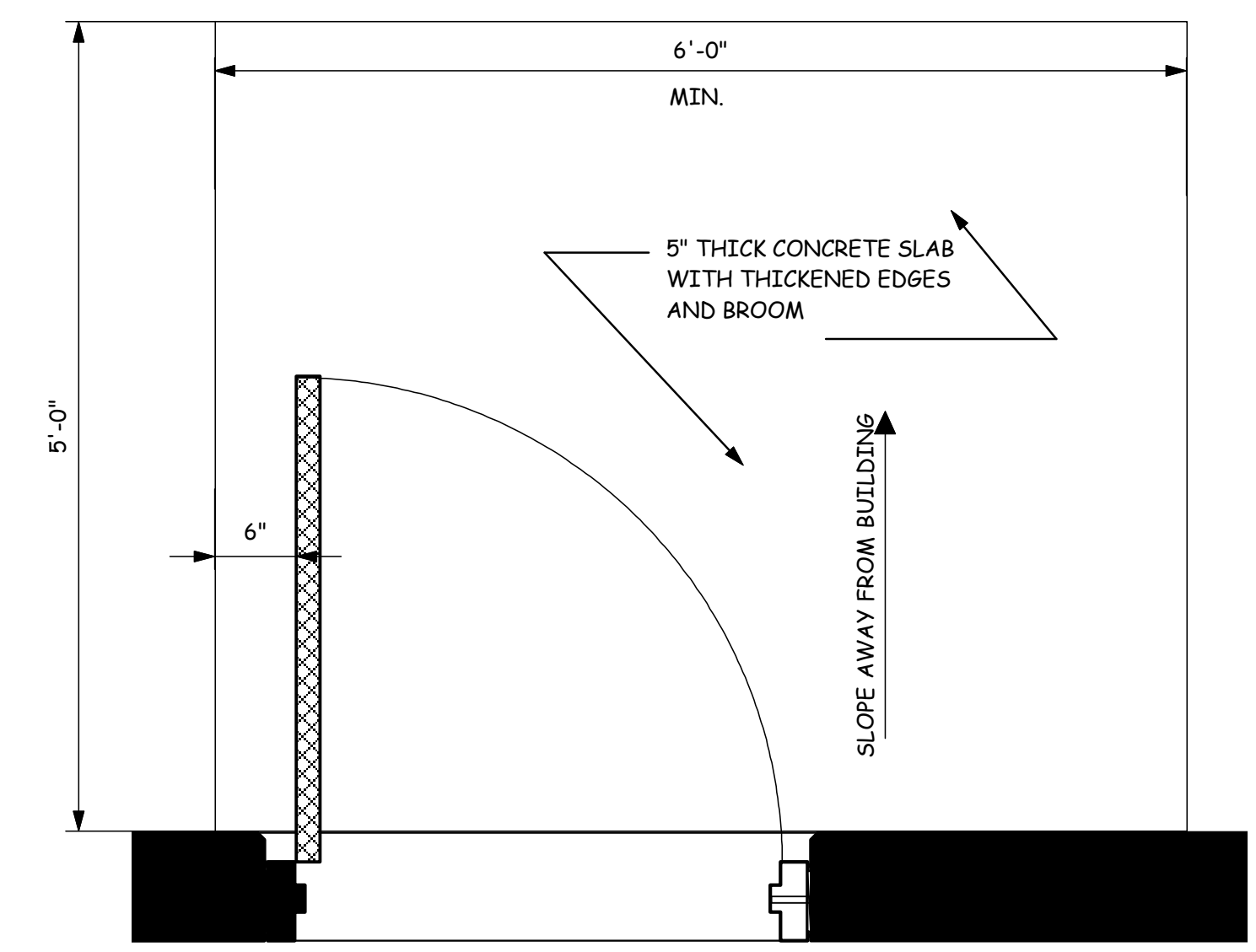

DETAIL-CONCRETE STOOP
1"=1'-0"

GENERAL NOTES:

- Building and site layout to be verified by licensed surveyor and written verification to be forwarded to owner.
- Contractor to verify all existing site conditions and notify Architect of any discrepancies.
- Refer to Civil drawings for site grading, storm drainage, dimensions, bearing angles and utilities to within 5'-0" of building.
- Demolition of existing curb to new approaches to be included in the general contract.
- All drive approaches shall be included in the General Contract per City and State standards.
- All exterior steel to be galvanized.
- The General Contractor shall obtain and pay for all permits and inspection fees for the installation of all work. It shall be the subcontractor's responsibility to call for local inspections and approvals from the Municipality.
- Contract drawings and specifications represent finished structure. They do not indicate method of construction. Contractor shall provide all measures necessary to protect structure and personnel during construction, (such measures shall include but not be limited to bracing, shoring of loads due to construction equipment, excavation protection, scaffolding, job site safety, etc. Observation visits to the site by Architect or Engineer shall not include inspection of above items).
- Unless otherwise provided in the contract documents. The Contractor shall provide and pay for all labor, materials, equipment, tools, construction equipment, machinery, transportation and other facilities and services necessary for the proper execution and completion of work.
- Contractor shall provide all fire suppression systems in accordance with NFPA 231 Class III codes. All required sprinkler plans shall be supplied by the Contractor and approved by local Fire Marshal, Owner's insurance company, and by designer.
- General Contractor to fill all planting areas with 6" landscape grade top soil.
- General Contractor is responsible for coordination of utility sleeving with Architectural plans prior to placing of sidewalks and paving.
- General Contractor to install signage for handicapped parking per Municipality and State specifications.
- Parking stall sizes to be as noted on drawing. Provide 4" wide painted stripes.
- Provide bollards 5'-0" from face of building to protect all utility services (where applicable).
- All wood blocking in contact with concrete or masonry to be wolmanized.
- Fire extinguishers by tenant per applicable Municipality and NFPA. Coordinate locations in office areas with Architect. Provided by tenant as required by local authorities. Extinguishers shall be mounted/identified in plain view not to exceed a maximum travel distance of 75 feet.
- It is the responsibility of the General Contractor to supervise and coordinate various trades on building face to allow for sufficient room for all equipment.
- Contractor to hold interior roof drains and downspouts as close as possible to columns, or walls, typically.
- All dimensions to face of gypsum board unless note otherwise (U.N.O.)
- Partitions are intended to hit exterior storefront at mullions U.N.O.. Provide closers, trim and coordinate installation of all window blinds.
- Where possible layout partitions from interior column lines.
- Stagger all joints of gyp bd construction.
- Do not scale drawings. Dimensions govern. Large scale detail drawings govern over smaller scale drawings.
- Contractor shall provide and install exit and emergency lighting per drawings and/or City codes.
- Contractor shall provide and install smoke detectors per Municipality requirements, coordinate location with Architect.
- Provide ground fault interceptors in wet areas, as required.
- Provide transition strips between floors of dissimilar materials.
- Provide control joints at interior gyp. bd. partitions every 30'-0" maximum spacing, at intersections of any walls attached to concrete panels or structural columns and where shown elsewhere on drawings.
- Provide "flex-track" connections at wall/roof deck intersections, gyp. bd. of the lower part of the wall will be attached only to the lower portion of the track and gyp. bd. above shall overlap at where a rated partition is noted on the drawings.
- Provide 5/8" WR/MR gypsum board on all restroom walls and other walls to receive ceramic tile or epoxy paint.
- Keying of all locks to be done by General Contractor's locksmith. General Contractor shall coordinate requirements with owner.
- General Contractor shall provide exterior "Knox Box" for Fire Department use. Quantity and location to be as directed by Fire Chief and coordinated with Architect and Owner.
- Note: Mechanical, electrical, and plumbing is design build by the General Contractor. Design, location, code compliance, layout and coordination of these services shall be the responsibility of the General Contractor.

COLORS: LEGEND AND BORDER-GREEN;
HC SYMBOL-WHITE ON BLUE
BACKGROUND: BACKGROUND-WHITE;
TUBE, ANGLES, ETC. -LT. GREY. NOTE:
PAINT BACK OF SIGN TO MATCH TUBE

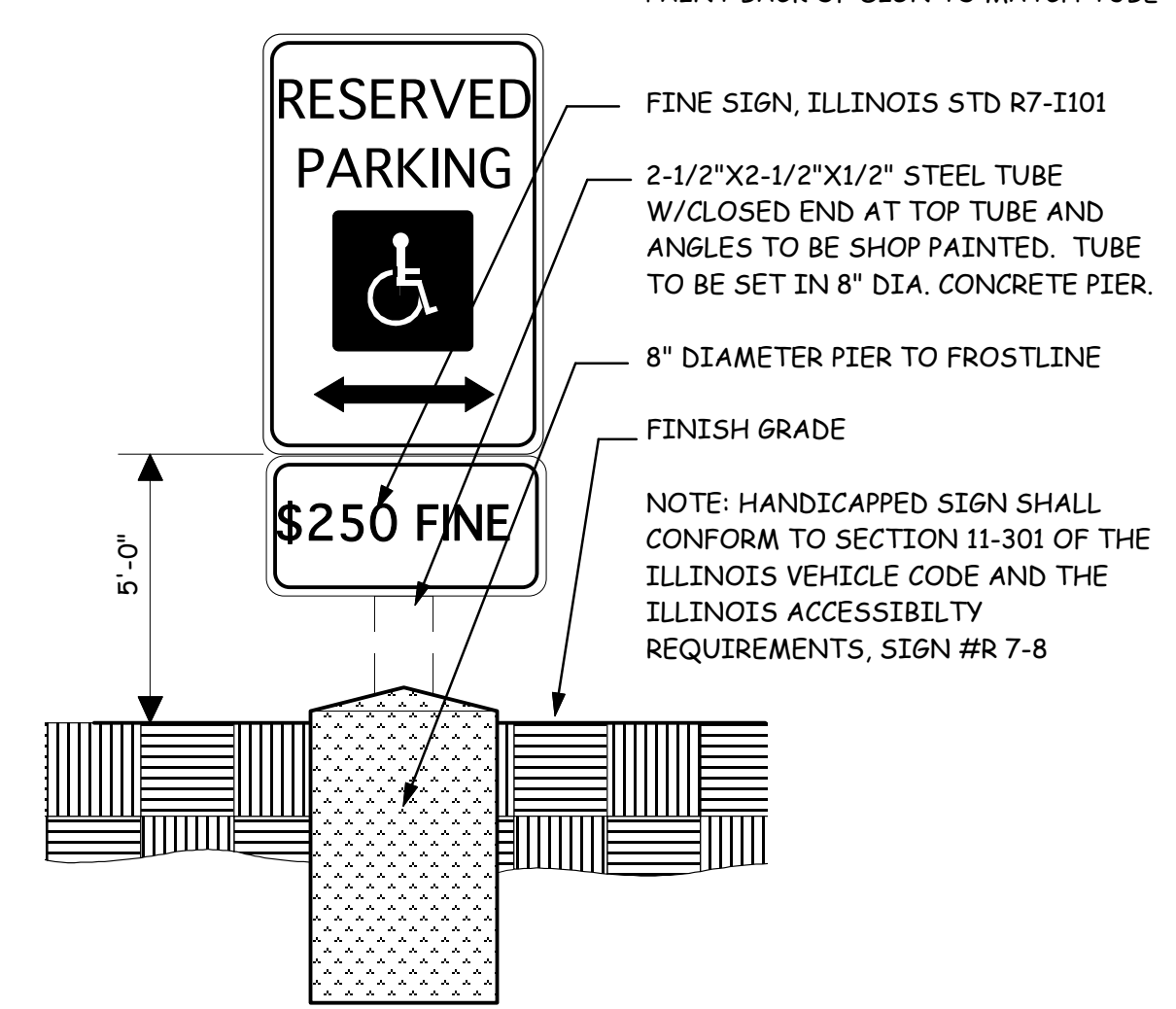

H.C. PARKING SIGN
NO SCALE

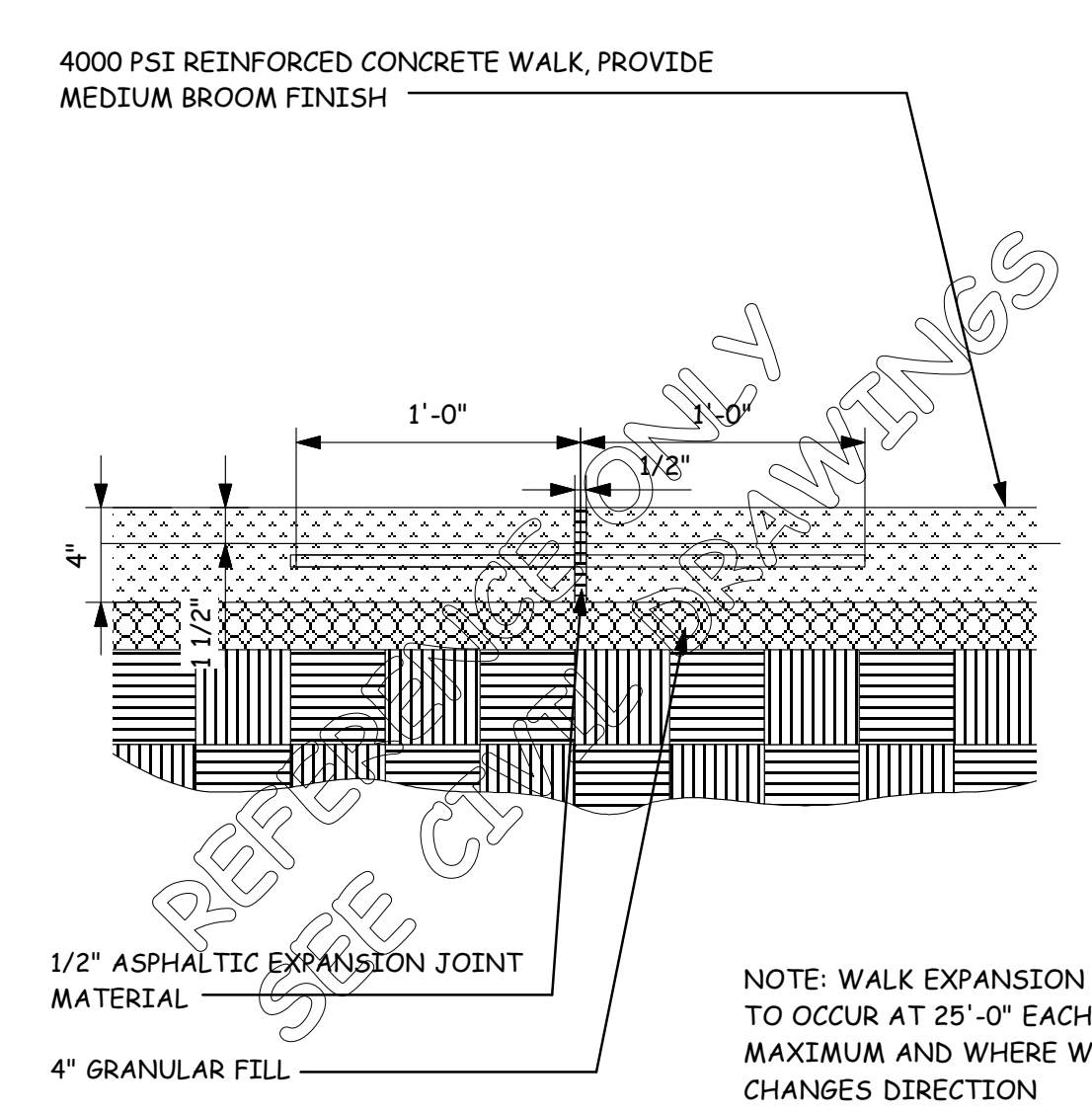

DETAIL-EXPANSION JOINT
1-1/2"=1'-0"

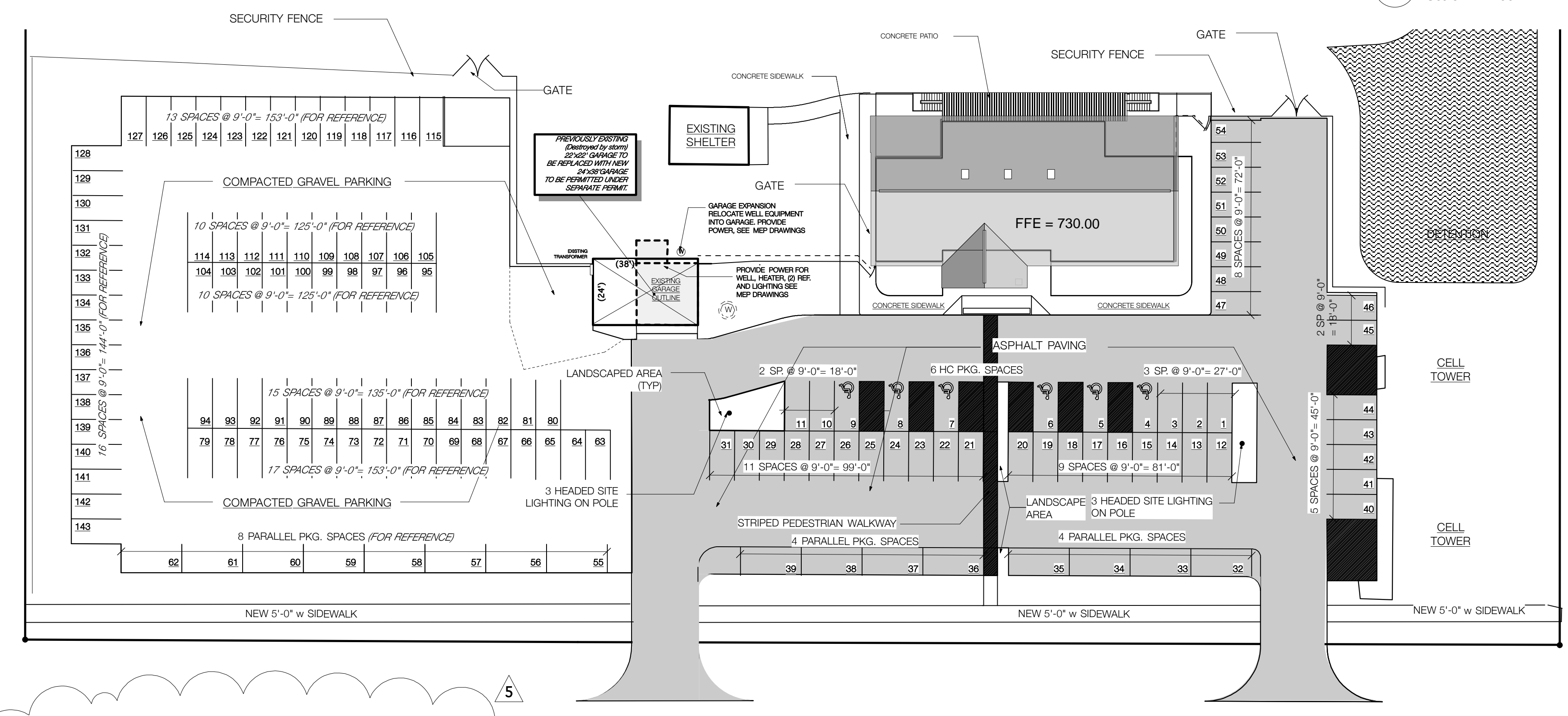

PARTIAL SITE PLAN
Scale: 1" = 30 ft

143 PARKING SPACES TOTAL

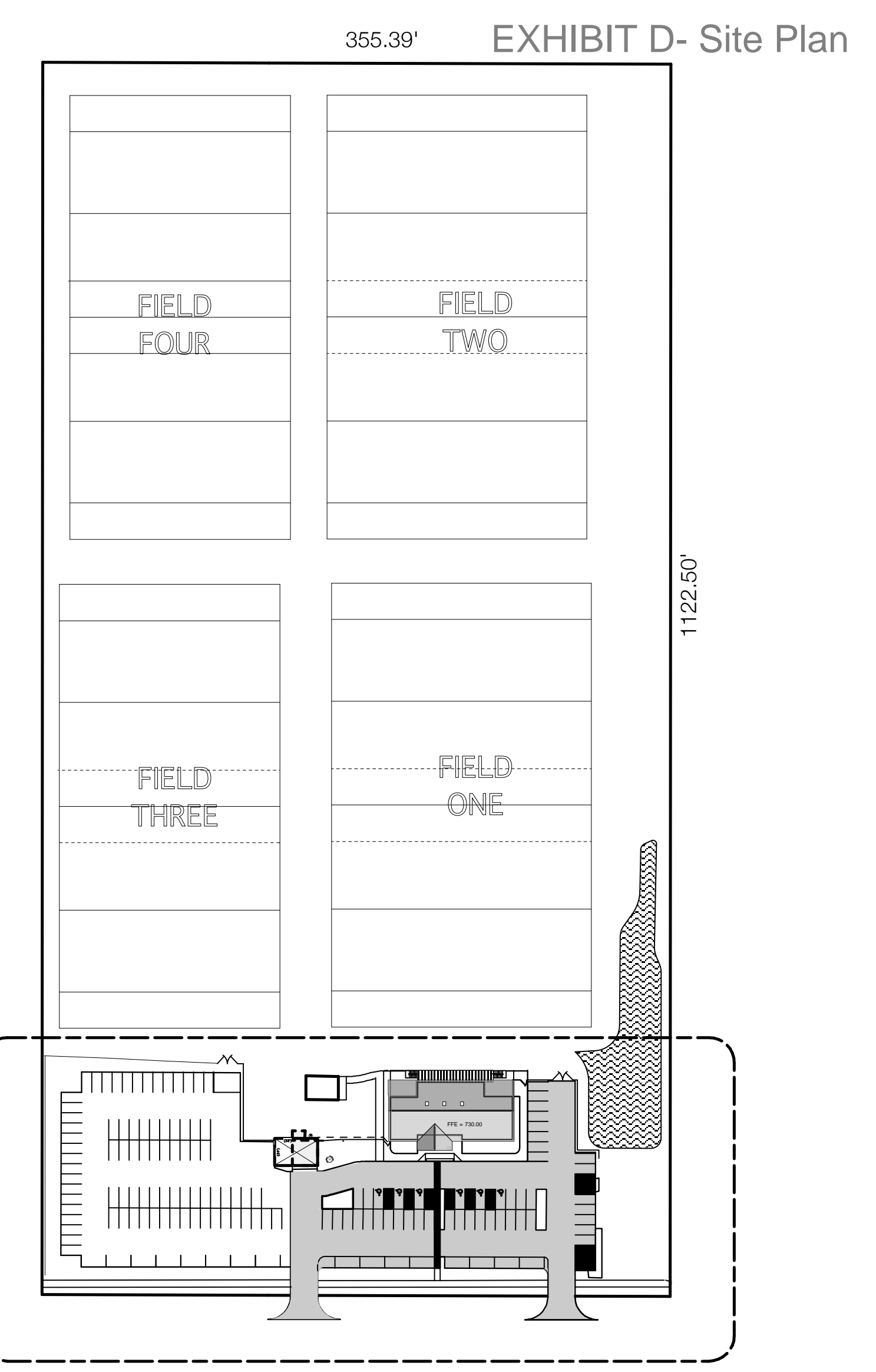

SITE PLAN
Scale: 1" = 100 ft

PLEASE NOTE:
REFER TO CIVIL ENGINEERING DRAWINGS BY OTHERS FOR FINAL DIMENSIONS, DETENTION REQUIREMENTS, BUILDING LOCATION, PAVING, ETC. FOR ACCURATE LAYOUT

PLEASE NOTE:
AUTOMOBILE PAVING: 3" BITUMINOUS ASPHALT OVER 8" GRANULAR FILL, TRUCK PAVING: 3" BITUMINOUS PAVING OVER 10" GRANULAR FILL, REFER TO CIVIL ENGINEERING DRAWINGS BY OTHERS

PLEASE NOTE:
THIS SHEET IS TO BE USED FOR ARCHITECTURAL REFERENCE ONLY, SEE CIVIL DRAWINGS BY OTHERS FOR ALL DIMENSIONS, PERTINANT DETAILS, ETC. AS REQUIRED.

REV	DESCRIPTION	DATE	APPROVED
5	Revise per Village Board	7/8/14	
4	Revise per PUD reqmts	4/24/14	
3	Rev-HCprkg/Lighting	2/5/14	
2	Issued For Permit	1/3/13	
1	ISSUED FOR APPROVAL	12/18/12	

REVISION HISTORY



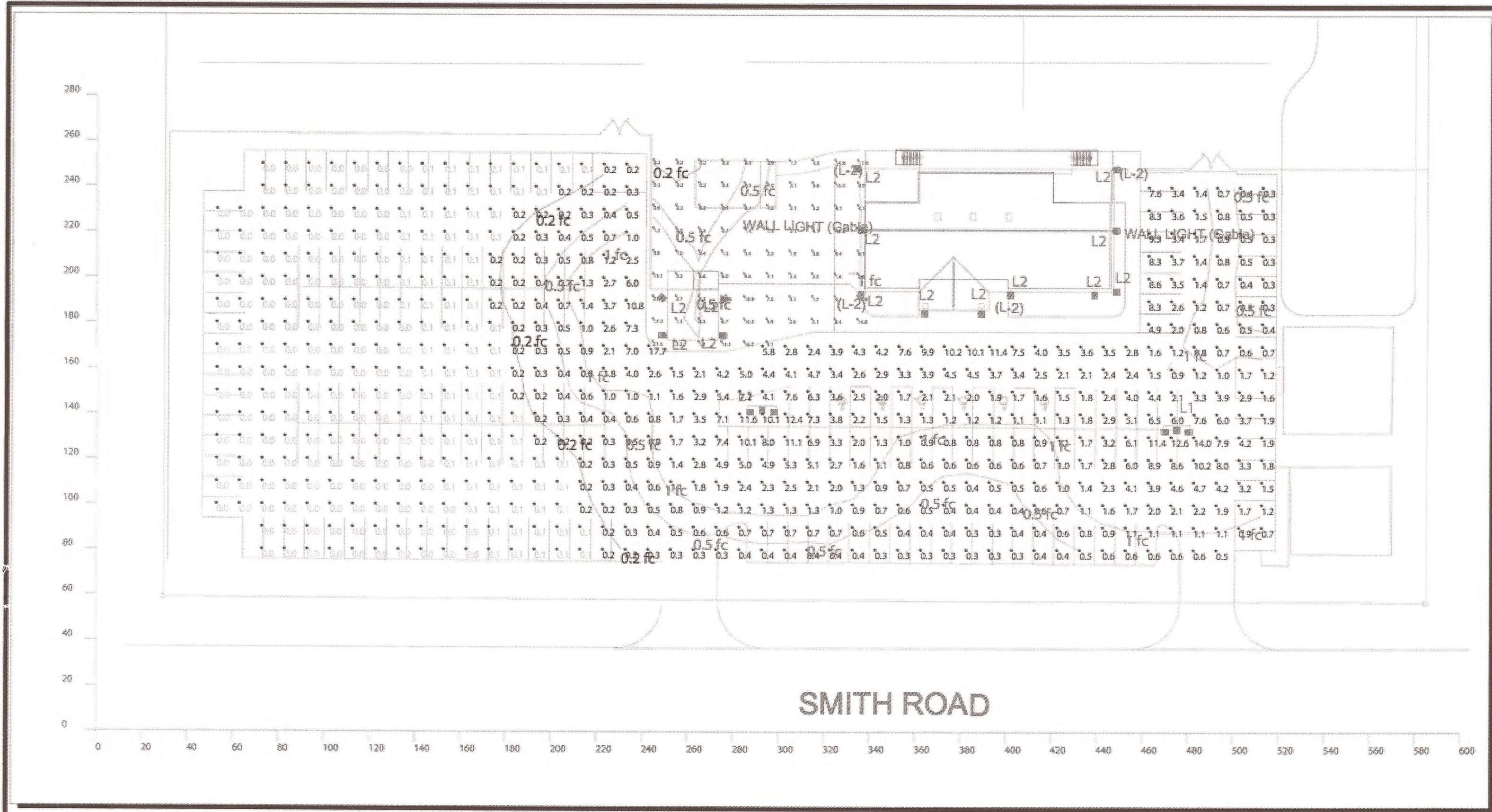

Scale: 1 inch = 40 Ft.

RAB LIGHTING	RAB Lighting 170 Ludlow Avenue Northvale, NJ 07647 Tel: (888) 722-1000 Fax: (888) 722-1232 WWW.RABWEB.COM	Prepared For: Electrical Marketing Group 7989 Maple Lane Bensenville, IL 60106 630-860-9556	Job Name: Blaze Clubhouse Lemont, IL Lighting Layout Version B	Scale: 0'-1" = 40'-0" Date: 4/25/2014 Filename: Blaze Clubhouse Layout 042514E.AGI Revised By: dvent.	This information is confidential and the sole property of RAB Lighting. It is not to be reproduced or distributed to others without the written permission of RAB Lighting. The calculation and results thereof as shown in this report are based on information provided by the customer. Therefore design parameters such as surface reflectances, sizes, mounting height, depreciation factors, orientation and tilt must be verified. RAB Lighting of systems all implied warranties with regard to actual installed light levels as compared to those based on inaccurate or incomplete data. RAB LIGHTING MAKES NO WARRANTIES OR REPRESENTATIONS, COMPLETENESS OR SUITABILITY OF DESIGN ILLUSTRATION FOR SATISFYING ANY APPLICABLE REGULATORY CODE REQUIREMENTS, NOT FOR CONSTRUCTION.
---------------------	--	---	--	--	--

Calculation Summary											
Label	CalcType	Units	Avg	Max	Min	Avg/Min	Max/Min	Description	PtSpCrL	PtSpCrB	Meter Type
CalcPls Grass Area	Illuminance	Fc	5.20	23.4	0.2	26.00	117.00	Readings Taken At 0'-0" AFG	10	10	Horizontal
CalcPls Parking Lot	Illuminance	Fc	1.41	17.7	0.0	N.A.	N.A.	Readings Taken at 0'-0" AFG	10	10	Horizontal

Luminaire Schedule									
Fixture Type	Symbol	Qty	Label	Arrangement	Lumens/Lamp	LLF	Description	Lum. Watts	Filename
L2	[Symbol]	14	FXLH200SFPSQ	SINGLE	19000	0.800	HID Floodlight 200PSMH Quad Tap	232	FXLH200PS - Splitfitter - LSI21306E.IES
L1	[Symbol]	2	FXLH250SFPSQ x 3 @ 90°	TRIPLE @ 90°	22500	0.800	HID Floodlight 250PSMH Quad Tap	288	FXLH250PS - Splitfitter - LSI21306E.IES

Luminaire Location Summary						
LumNo	Label	X	Y	Mtg Ht	Orient	Tilt
3	FXLH200SFPSQ	357.5	289.75	10	180	55
4	FXLH200SFPSQ	358.007	215.583	10	270	55
5	FXLH200SFPSQ	469.264	269.723	10	0	55
6	FXLH200SFPSQ	469.136	242.696	10	0	55
7	FXLH200SFPSQ	469.311	215.861	10	0	55
8	FXLH200SFPSQ	424.012	215.678	10	270	55
9	FXLH200SFPSQ	359.385	242.725	10	180	55
10	FXLH200SFPSQ	460.938	215.678	10	270	55
11	FXLH200SFPSQ	386.175	207.168	10	270	55
12	FXLH200SFPSQ	411.248	207.169	10	270	55
15	FXLH250SFPSQ x 3 @ 90°	497.294	156.889	20	270	55
17	FXLH250SFPSQ x 3 @ 90°	314.735	165.223	20	270	55
19	FXLH200SFPSQ	271.553	211.944	10	139	491
20	FXLH200SFPSQ	272.122	198.214	10	180	55
21	FXLH200SFPSQ	297.001	211.828	10	31	495
22	FXLH200SFPSQ	296.158	196.099	10	0	55

Total Quantity: 16

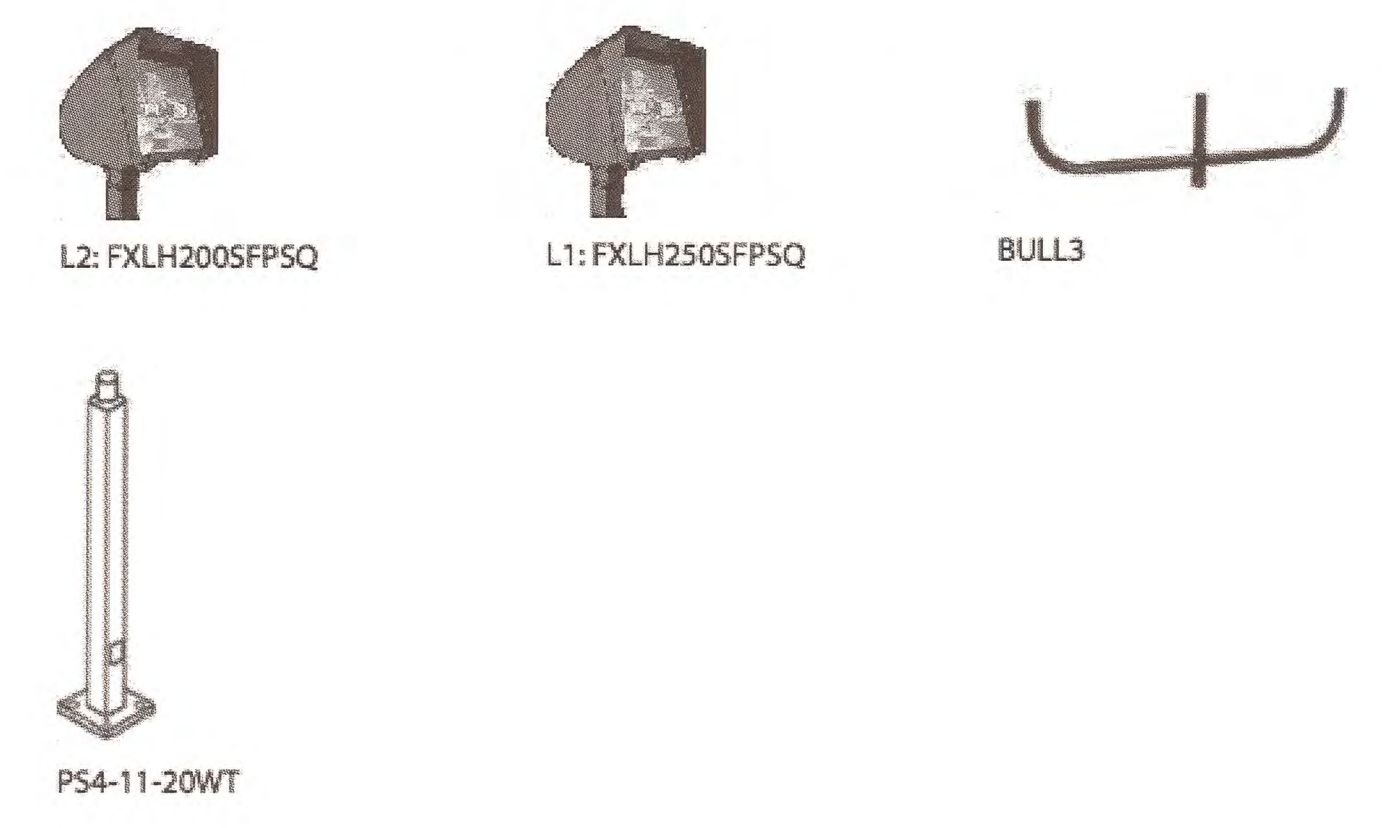

NOTES:

- * EXACT MOUNTING DETAILS TO BE DETERMINED AT JOBSITE BY OTHERS MOUNTING HEIGHT EXHIBITED ON DRAWING, SET TO BOTTOM OF FIXTURE HOUSING.
- * THE LIGHT LOSS FACTOR (LLF) IS A PRODUCT OF THE LAMP LUMEN DEPRECIATION (LLD), THE LUMINAIRE DIRT DEPRECIATION (LDD) AND THE BALLAST FACTOR (BF).
- * THE LDD IS JOB SPECIFIC.
- * THE LLF IS THE RESULT (QUOTIENT) OF MEAN LUMENS / INITIAL LUMENS PER LAMP MANUFACTURER.
- * THE BF IS PROVIDED BY THE BALLAST MANUFACTURER.
- * VALUES SHOWN ARE PREDICTED HORIZONTAL FOOTCANDLES TAKEN AT GRADE. ACTUAL READINGS MAY VARY, DETERMINATE OF EQUIPMENT, ELEVATION OPERATIONAL HOURS OF USE, OBSTRUCTIONS, VARIATIONS IN REFLECTANCES AND / OR ENVIRONMENTAL VARIABLES.
- ***BASED ON IES RECOMMENDED PRACTICES, I WOULD NOT RECOMMEND THIS LAYOUT.

RAB LIGHTING	RAB Lighting 170 Ludlow Avenue Northvale, NJ 07647 Tel: (888) 722-1000 Fax: (888) 722-1232 WWW.RABWEB.COM	Prepared For: Electrical Marketing Group 7989 Maple Lane Bensenville, IL 60106 630-860-9556	Job Name: Blaze Clubhouse Lemont, IL Lighting Layout Version B	Scale: NTS Date: 4/25/2014 Filename: Blaze Clubhouse Layout 042514E.AGI Revised By: dvent.	This information is confidential and the sole property of RAB Lighting. It is not to be reproduced or distributed to others without the written permission of RAB Lighting. The calculation and results thereof as shown in this report are based on information provided by the customer. Therefore design parameters such as surface reflectances, sizes, mounting height, depreciation factors, orientation and tilt must be verified. RAB Lighting of systems all implied warranties with regard to actual installed light levels as compared to those based on inaccurate or incomplete data. RAB LIGHTING MAKES NO WARRANTIES OR REPRESENTATIONS, COMPLETENESS OR SUITABILITY OF DESIGN ILLUSTRATION FOR SATISFYING ANY APPLICABLE REGULATORY CODE REQUIREMENTS, NOT FOR CONSTRUCTION.
---------------------	--	---	--	---	--

FXLH200SFPSQ

Specification Grade 400 and 250 watt HID floodlight with cutting edge design, architectural quality, superior features and mounting options at competitive prices.

Lamp Info	Ballast Info
Type: T16 Watts: 200W Shape/Size: N/A Base: N/A ANSI: N/A Hours: 15,000 Lamp Lumens: 19,000 Efficacy: 82 LPW	Type: CWA-HPF QT Watts: 1,402.0A Shape/Size: N/A Base: N/A ANSI: N/A Hours: 12,000 Lamp Lumens: 22,600 Efficacy: 78 LPW

Technical Specifications

UL Listing:
Suitable for wet locations. Suitable for mounting within 1.2m (4ft) of the ground.

Housing:
Precision die cast aluminum with Wall Bracket, Trunion or Slipfitter.

Reflector:
Anodized aluminum. Field adjustable beam spread.

Lens Frame & Glare Shield:
Precision die cast aluminum. Hinged for easy access. Phillips head screws for added security.

Socket:
HID Porcelain 4kv Pulse Rated socket with nickel plated screw shell CFL Plug in type, GX24q-4 base.

Finish:
Our environmentally friendly polyester powder coatings are formulated for high-durability and long-lasting color, and contains no VOC or toxic heavy metals.

Lens:
Thermal tempered shock resistant glass, 3/16" thick.

Lens Gasket:
High temperature one piece molded silicone set in die cast retaining groove. Remains in place during relamping.

EPA:
Maximum EPA 2.0.

Pulse Start:
Pulse Start metal halide for increased lamp life, lumen maintenance, color uniformity and efficiency.

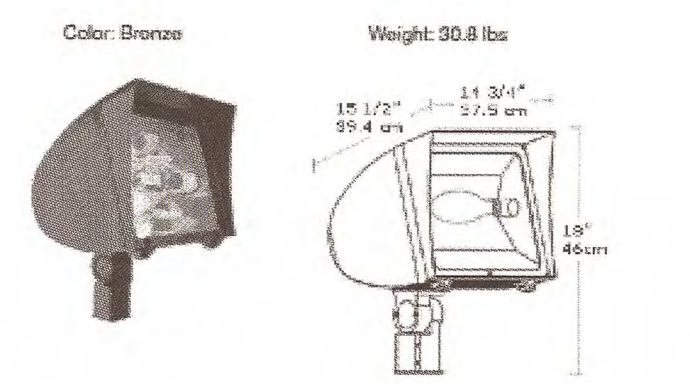

Patents:
Pat. D552,283.

Country of Origin:
Designed by RAB in New Jersey and assembled in the USA by RAB's IBEW Local 3 workers.

Buy American Act Compliant:
This product is a COTS item manufactured in the United States, and is compliant with the Buy American Act.

Recovery Act (ARRA) Compliant:
This product complies with the 52.225-21 "Required Use of American Iron, Steel, and Manufactured Goods--Buy American Act-- Construction Materials (October 2010).

Trade Agreements Act Compliant:
This product is a COTS item manufactured in the United States, and is compliant with the Trade Agreements Act.

GSA Schedule:
Suitable in accordance with FAR Subpart 25.4.

FXLH250SFPSQ

Specification Grade 400 and 250 watt HID floodlight with cutting edge design, architectural quality, superior features and mounting options at competitive prices.

Lamp Info	Ballast Info
Type: ED28 Watts: 250W Shape/Size: N/A Base: N/A ANSI: N/A Hours: 12,000 Lamp Lumens: 22,600 Efficacy: 78 LPW	Type: CWA-HPF QT Watts: 1,402.0A Shape/Size: N/A Base: N/A ANSI: N/A Hours: 12,000 Lamp Lumens: 22,600 Efficacy: 87%

Technical Specifications

UL Listing:
Suitable for wet locations. Suitable for mounting within 1.2m (4ft) of the ground.

Housing:
Precision die cast aluminum with Wall Bracket, Trunion or Slipfitter.

Reflector:
Anodized aluminum. Field adjustable beam spread.

Lens Frame & Glare Shield:
Precision die cast aluminum. Hinged for easy access. Phillips head screws for added security.

Socket:
HID Porcelain 4kv Pulse Rated socket with nickel plated screw shell CFL Plug in type, GX24q-4 base.

Finish:
Our environmentally friendly polyester powder coatings are formulated for high-durability and long-lasting color, and contains no VOC or toxic heavy metals.

Lens:
Thermal tempered shock resistant glass, 3/16" thick.

Lens Gasket:
High temperature one piece molded silicone set in die cast retaining groove. Remains in place during relamping.

EPA:
Maximum EPA 2.0.

Pulse Start:
Pulse Start metal halide for increased lamp life, lumen maintenance, color uniformity and efficiency.

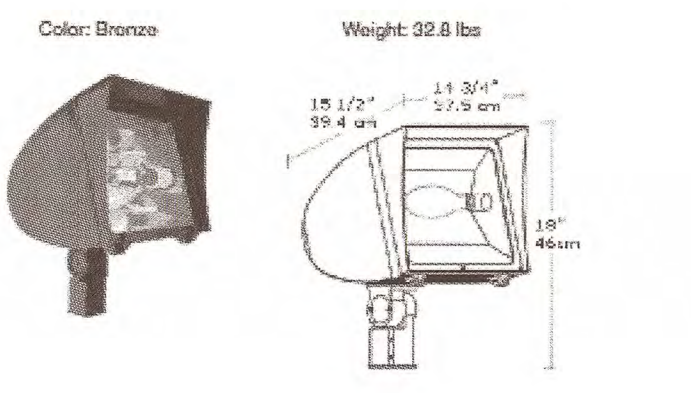

Patents:
Pat. D552,283.

Country of Origin:
Designed by RAB in New Jersey and assembled in the USA by RAB's IBEW Local 3 workers.

Buy American Act Compliant:
This product is a COTS item manufactured in the United States, and is compliant with the Buy American Act.

Recovery Act (ARRA) Compliant:
This product complies with the 52.225-21 "Required Use of American Iron, Steel, and Manufactured Goods--Buy American Act-- Construction Materials (October 2010).

Trade Agreements Act Compliant:
This product is a COTS item manufactured in the United States, and is compliant with the Trade Agreements Act.

GSA Schedule:
Suitable in accordance with FAR Subpart 25.4.

BULL3

Bulhorn bracket safely supports HID floodlights. Great with Floodilla, Megafood and Flexfood models.

Technical Specifications

Finish:
Our environmentally friendly polyester powder coatings are formulated for high-durability and long-lasting color, and contains no VOC or toxic heavy metals.

Bulhorns:
3 tenons for slip fitters. Bulhorns fit 2 3/8" (6cm) O.D. tenons and accommodate 2 3/8" (6cm) slip fitters. Steel tubing 150" and 200" thick welded with (4) 3/8" bolts for securing to pole.

Slipfitters & Wall Brackets:
3/16" thick steel with 1/2" nuts and bolts.

Bracket EPA:
2.0.

Weight:
31 lbs.

Maximum Weight Capacity:
90 lbs. per arm.

EPA Maximum Capacity:
4.0.

Patents:
The designs of fixtures are protected under U.S. and international intellectual property laws.

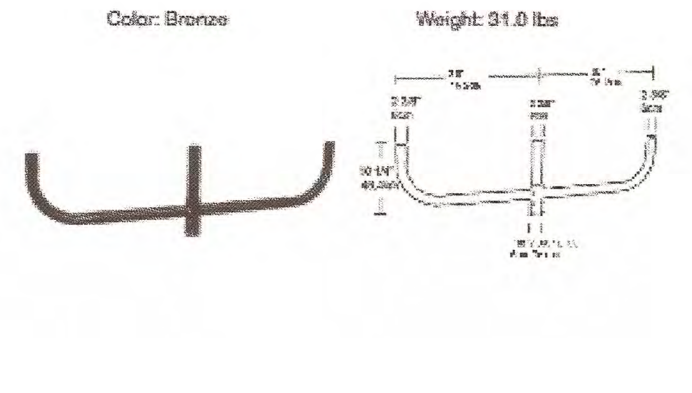

PS4-11-20WT

Square steel poles with welded tenon included for use with floodlights. Designed for ground mounting. Poles are stocked nationwide for quick shipment. Protective packaging ensures poles arrive at the job site good as new.

Lamp Info

Type: N/A Watts: 0W Shape/Size: N/A Base: N/A ANSI: N/A Hours: 0 Lamp Lumens: 0 Efficacy: N/A	Type: N/A Watts: 120V: N/A Shape/Size: N/A Base: N/A ANSI: N/A Hours: 0 Input Watts: 0W Efficacy: N/A
--	--

Technical Specifications

CSA Listed:
Suitable for wet locations.

Shaft:
45,000 p.s.i. minimum yield.

Hand Holes:
Reinforced with grounding lug and removable cover.

Base Plates:
Slotted base plates 36,000 p.s.i.

Shipping Protection:
All poles are shipped in individual corrugated cartons to prevent finish damage.

Color:
Bronze powder coating.

Tenon:
Welded 2 3/8" tenon included.

Terms of Sale:
Pole Terms of Sale is available.

Height:
20 FT.

Gauge:
11

Wall Thickness:
1/8".

Shaft Size:
4".

Hand Hole Dimensions:
3" x 5".

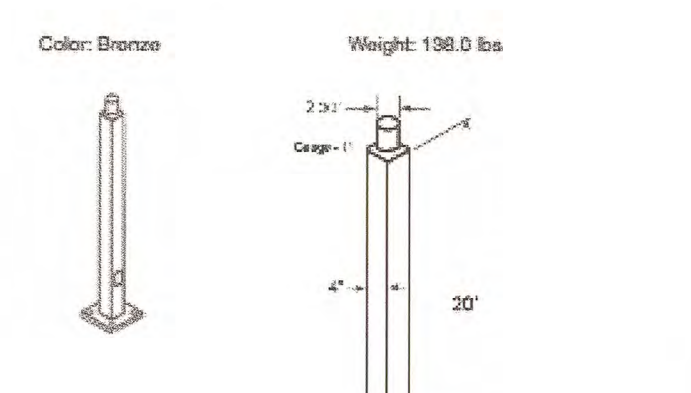

Bolt Circle:
8-9".

Base Dimension:
8".

Weight:
138 lbs.

Anchor Bolt:
Galvanized anchor bolts and galvanized hardware and anchor bolt template. All bolts have a 3" hook.

Anchor Bolt Templates:
WARNING: Template must be printed on 11" x 17" sheet for actual size. CHECK SCALE BEFORE USING. Templates shipped with anchor bolts and available.

Pre-Shipped Anchor Bolts:
Bolts can be pre-shipped upon request for additional freight charge.

MaxEPA's/Max Weights:
70MPH 8.3 ft./240 lb
80MPH 5.6 ft./165 lb
90MPH 3.6 ft./110 lb
100MPH 2.2 ft./75 lb
110MPH 1.0 ft./45 lb
120MPH 0.2 ft./20 lb.

schmid DESIGN inc.
 Architecture
 Planning
 Interior Design
 707 CLINTON AVENUE
 OAK PARK, IL 60304
 TELEPHONE 708-524-5404
 FAX 708-524-5420

Chicago Blaze Building Corporation, Inc.
 13011 W. Smith Road
 Lemont, Illinois 60439



PH-1
PHOTOMETRICS/
PARKING LOT
LIGHTING

2	Revise per H-UJ reqmts	4/25/14	
1	SUBMITTED PER CITY REQUEST	2/24/14	
REV	DESCRIPTION	DATE	APPROVED
REVISION HISTORY			

to: Mayor Brian K. Reaves
Village Board of Trustees

from: James L. Cainkar, P.E., P.L.S., Acting Village Engineer

subject: **Smith Farms Detention Basin Repairs**

date: August 25, 2014

BACKGROUND/HISTORY

Requests for Proposals were solicited, and three (3) bids were received on August 1, 2014 @ 10:00 am for Smith Farms Detention Basin Repairs project, which work consists of the removal and reinstallation of existing failing block wall; adjusting catch basins; and regrading & restoration of a detention basin bottom. The low bidder was Country Landscape & Supply, Inc., 13305 West 131st Street, Lemont, IL 60439, which bid was in the amount of \$15,947.26. The bid was \$3,602.74 (18.43%) below the Engineer's Estimate of \$19,550.00.

RECOMMENDATION

Award of the Smith Farms Detention Basin Repairs Project, to Country Landscape & Supply, Inc., based on their bid amount of \$15,947.26 will allow the project to proceed on schedule. This project is being funded by the remaining monies in the Smith Farms escrow account.

ATTACHMENTS

- Resolution Authorizing Award of Contract
- Letter of Award Recommendation; and
- Bid Tabulation listing the bid received, including company name, address and amount of bid.

VILLAGE BOARD ACTION REQUIRED

Approval of Resolution awarding the contract to Country Landscape & Supply, Inc..

RESOLUTION

RESOLUTION AUTHORIZING AWARD OF CONTRACT

Smith Farms Detention Basin Repairs

WHEREAS, the Village of Lemont requires that the Smith Farms Detention Basin Repairs, be completed; and

WHEREAS, the Village seeks to utilize the construction firm of Country Landscape & Supply, Inc. for such work; and

WHEREAS, Country Landscape & Supply, Inc. submitted a low bid for such work in the amount of \$15,947.26.

NOW, THEREFORE, BE IT RESOLVED, by the President and Board of Trustees that the Contract with Country Landscape & Supply, Inc. is hereby approved.

PASSED AND APPROVED BY THE PRESIDENT AND BOARD OF TRUSTEES OF THE VILLAGE OF LEMONT, COUNTIES OF COOK, WILL AND DuPAGE, ILLINOIS, on this 8th day of September, 2014.

AYES

NAYS

PASSED

ABSENT

Debby Blatzer
Paul Chialdikas
Clifford Miklos
Rick Sniegowski
Ronald Stapleton
Jeanette Virgilio

CHARLENE SMOLLEN, Village Clerk

Approved by me this **8th day of September, 2014.**

A t t e s t:

BRIAN K. REAVES, Village President

CHARLENE SMOLLEN, Village Clerk



Frank Novotny & Associates, Inc.

825 Midway Drive ♦ Willowbrook, IL ♦ 60527 ♦ Telephone: (630) 887-8640 ♦ Fax: (630) 887-0132

Civil Engineers/
Municipal Consultants

August 18, 2014

Mr. George Schafer
Administrator
Village of Lemont
418 Main Street
Lemont, Illinois 60439

Re: **Smith Farms Detention Basin Repairs**

Dear George:

Listed below and on the attached "Tabulation of Proposals" are the results of the Request for Proposals, dated August 1, 2014, for the above-captioned project. A summary is as follows:

Country Landscape & Supply.....	\$15,947.26
Hoppy's Landscaping	\$19,280.00
Copenhaver Construction.....	\$27,700.00

The low proposal submitted by Country Landscape & Supply, in the amount of \$15,947.26, is \$3,602.74 (18.43%) below the Engineer's Estimate of \$19,550.00. Country Landscape & Supply, Inc. has satisfactorily performed work in the Village in the past, and is qualified to perform this type of work. We, therefore, recommend that the Contract be awarded to **Country Landscape & Supply, Inc., 13305 W. 131st Street, Lemont, IL 60439**, in the amount of **\$15,947.26**.

Please call if you have any questions regarding this matter.

Very truly yours,

FRANK NOVOTNY & ASSOCIATES, INC.

James L. Cainkar, P.E., P.L.S.

JLC/dan
Enclosure

cc: Mr. Ralph Pukula, Director of Public Works, w/Enc.
Ms. Linda Molitor, Executive Assistant, w/Enc.
File No. 14283

14283 Bid Tab Letter 081814

Date: 8/20/2014

TABULATION OF PROPOSALS

Page 1 Of 1

OWNER: Village of Lemont
 PROJECT DESCRIPTION: Smith Farms Detention Basin Repairs

PROJECT NO : 14283

PROPOSAL DUE DATE: August 15, 2014 @ 10:00 a.m.

				Engineers Estimate		Country Landscape & Supply 13305 W. 131st Street Lemont, IL 60439		Hoppy's Landscaping 15041 New Avenue Lockport, IL 60441		Copenhaver Construction 75 Koppie Drive Gilberts, IL 60136		
Item No	Description	Unit	Quantity	Unit Price	Amount	Unit	Amount	Unit Price	Amount	Unit Price	Amount	
1	Existing Failed Modular Block Wall, Remove and Re-install (Per SqFt of Wall Face)	SQ FT	350	25.00	8,750.00	21.99	7,696.50	25.00	8,750.00	50.00	17,500.00	
2	Catch Basins to be Adjusted (4" Lower)	EACH	2	600.00	1,200.00	225.58	451.16	250.00	500.00	500.00	1,000.00	
3	Earth Excavation (from Detention Basin Bottom)	CU YD	60	80.00	4,800.00	71.46	4,287.60	70.50	4,230.00	60.00	3,600.00	
4	Grading & Restoration (Topsoil & Seed with Erosion Control Blanket) of all Disturbed Areas	SQ YD	800	6.00	4,800.00	4.39	3,512.00	7.25	5,800.00	7.00	5,600.00	
Totals:					19,550.00	15,947.26	19,280.00	27,700.00				
Bid Error Corrections:												
Corrected Totals ---						15,947.26	19,280.00	27,700.00				
Over / Under ----						-3,602.74	-270.00	8,150.00				
Percent ----						-18.43%	-1.38%	41.69%				

to: Mayor Brian K. Reaves
Village Board of Trustees

from: James L. Cainkar, P.E., P.L.S., Acting Village Engineer

subject: **Building Demolition (at IL Route 83 & Main Street)**
12897 Main Street
10970 Archer Avenue
10980 Archer Avenue
10990 Archer Avenue

date: September 2, 2014

BACKGROUND/HISTORY

Nine (9) bids were received on August 29, 2014 @ 10:00 am for Building Demolition project, which work consists of the demolition and disposal of buildings at four (4) sites at 12897 Main Street, 10970 Archer Avenue, 10980 Archer Avenue, and 10990 Archer Avenue, including asbestos removal (at 10990 Archer Avenue); water service disconnections; temporary chain link security fence; and all other appurtenant work as required. The low bidder was Green Demolition, 1427 West Dickens Avenue, Chicago, IL 60614, which bid was in the amount of \$173,196.00. The bid was \$\$18,804.00 (9.79%) below the Engineer's Estimate of \$192,000.00.

RECOMMENDATION

Award of the Building Demolition Project, to Green Demolition, based on their bid amount of \$173,196.00 will allow the project to proceed on schedule.

ATTACHMENTS

- Resolution Authorizing Award of Contract
- Letter of Award Recommendation; and
- Bid Tabulation listing the bid received, including company name, address and amount of bid.

VILLAGE BOARD ACTION REQUIRED

Approval of Resolution awarding the contract to Green Demolition.

RESOLUTION

RESOLUTION AUTHORIZING AWARD OF CONTRACT

Building Demolition (at IL Route 83 & Main Street)

**12897 Main Street
10970 Archer Avenue
10980 Archer Avenue
10990 Archer Avenue**

WHEREAS, the Village of Lemont requires that the Building Demolition (at Route 83 and Main Street) project, be completed; and

WHEREAS, the Village seeks to utilize the construction firm of Green Demolition for such work; and

WHEREAS, Green Demolition submitted a low bid for such work in the amount of \$173,196.00.

NOW, THEREFORE, BE IT RESOLVED, by the President and Board of Trustees that the Contract with Green Demolition is hereby approved.

PASSED AND APPROVED BY THE PRESIDENT AND BOARD OF TRUSTEES OF THE VILLAGE OF LEMONT, COUNTIES OF COOK, WILL AND DuPAGE, ILLINOIS, on this 8th day of September, 2014.

AYES NAYS PASSED ABSENT

Debby Blatzer
Paul Chialdikas
Clifford Miklos
Rick Sniegowski
Ronald Stapleton
Jeanette Virgilio

CHARLENE SMOLLEN, Village Clerk

Approved by me this 8th day of September, 2014.

A t t e s t:

BRIAN K. REAVES, Village President

CHARLENE SMOLLEN, Village Clerk



Frank Novotny & Associates, Inc.

825 Midway Drive ♦ Willowbrook, IL ♦ 60527 ♦ Telephone: (630) 887-8640 ♦ Fax: (630) 887-0132

Civil Engineers/
Municipal Consultants

September 2, 2014

Mr. George Schafer
Administrator
Village of Lemont
418 Main Street
Lemont, Illinois 60439

Re: **Building Demolition (at Route 83 and Main Street)**
12897 Main Street
10970 Archer Avenue
10980 Archer Avenue
10990 Archer Avenue

Dear George:

Listed below and on the attached "Bid Tabulation", please find the results of the August 29, 2014 bid opening for the above-captioned project. Nine (9) bids were received and tabulated, with no errors being found. A summary is as follows:

Green Demolition	\$ 173,196.00
American Demolition Corp.	181,450.00
KLF Demolition.....	188,650.00
Copenhaver Construction.....	213,500.00
N.F. Demolition.....	218,039.00
Brandenburg Industrial Service Company.....	229,000.00
Omega Demolition.....	260,000.00
National Wrecking Company.....	271,000.00
Alpine Demolition Services.....	281,562.00
 Engineer's Estimate.....	 \$ 192,000.00

The low bid submitted by Green Demolition, in the amount of \$173,196.00, is \$18,804.00 (9.79%) below the Engineer's Estimate of \$192,000.00. Since Green Demolition is qualified to perform this type of work, we therefore recommend that the Contract be awarded to **Green Demolition, 1427 West Dickens Avenue, Chicago, IL 60614**, in the amount of **\$173,196.00**.

Please note that the capping of the wells on all four (4) of the properties is being performed under separate contract, at an estimated total cost of \$12,000.00.

Should you have any questions concerning this matter, please do not hesitate to contact me.

Very truly yours,
FRANK NOVOTNY & ASSOCIATES, INC.

James L. Cainkar, P.E., P.L.S.

JLC/dn
Enclosure

cc: Mr. Ralph Pukula, Director of Public Works, w/Enc.
Ms. Linda Molitor, Executive Assistant, w/Enc.
Ms. Christina Smith, Finance Director, w/Enc.
File No. 14270

Date: 9/2/2014

TABULATION OF BIDS

OWNER: Village of Lemont
 PROJECT DESCRIPTION: Building Demolition
 12897 Main Street, 10970 Archer Avenue, 10980 Archer Avenue, and 10990 Archer Avenue
 BID OPENING: August 29, 2014 at 10:00 am

PROJECT NO : 14270

Item No	Description	Unit	Quantity	Engineers Estimate		Green Demolition Contr. 1427 West Dickens Avenue Chicago, IL 60614 5% Bid Bond		American Demolition Corp. 305 Ramona Avenue Elgin, IL 60120 5% Bid Bond		KLF Enterprises, Inc. 2300 West 167th Street Markham, IL 60428 5% Bid Bond		Copenhaver Construction 75 Koppie Drive Gilberts, IL 60136 5% Bid Bond		N.F. Demolition 16W050 Jeans Road Lemont, IL 60439 5% Bid Bond	
				Unit Price	Amount	Unit Price	Amount	Unit Price	Amount	Unit Price	Amount	Unit Price	Amount	Unit Price	Amount
1	Building Demolition, 12897 Main Street, Complete	L SUM	1	30,000.00	30,000.00	65,649.00	65,649.00	80,000.00	80,000.00	85,000.00	85,000.00	89,000.00	89,000.00	95,428.00	95,428.00
2	Building Demolition, 10970 Archer Avenue, Complete	L SUM	1	30,000.00	30,000.00	25,349.00	25,349.00	25,935.00	25,935.00	18,500.00	18,500.00	31,000.00	31,000.00	20,606.00	20,606.00
3	Building Demolition, 10980 Archer Avenue, Complete	L SUM	1	80,000.00	80,000.00	43,349.00	43,349.00	39,900.00	39,900.00	31,650.00	31,650.00	16,000.00	16,000.00	48,138.00	48,138.00
4	Building Demolition, 10990 Archer Avenue, Complete	L SUM	1	30,000.00	30,000.00	27,049.00	27,049.00	11,945.00	11,945.00	31,000.00	31,000.00	37,000.00	37,000.00	35,166.00	35,166.00
5	Water Service Disconnection, Complete	EACH	4	1,000.00	4,000.00	750.00	3,000.00	2,150.00	8,600.00	2,500.00	10,000.00	3,000.00	12,000.00	2,162.00	8,648.00
6	Temporary Security Chain Link Fence, 6'-Height,	L SUM	1	5,000.00	5,000.00	1,800.00	1,800.00	7,200.00	7,200.00	2,500.00	2,500.00	16,000.00	16,000.00	300.00	300.00
7	Asbestos Removal, 10990 Archer Avenue	L SUM	1	5,000.00	5,000.00	5,000.00	5,000.00	7,870.00	7,870.00	7,500.00	7,500.00	9,000.00	9,000.00	6,953.00	6,953.00
8	Insurance Provisions - Complete	L SUM	1	8,000.00	8,000.00	2,000.00	2,000.00	0.00	0.00	2,500.00	2,500.00	3,500.00	3,500.00	1,800.00	1,800.00
Totals:					192,000.00		173,196.00		181,450.00		188,650.00		213,500.00		218,039.00
Bid Error Corrections:															
Corrected Totals ---							173,196.00		181,450.00		188,650.00		213,500.00		218,039.00
Over / Under ----							-18,804.00		-10,550.00		-3,350.00		21,500.00		26,039.00
Percent ----							-9.79%		-5.49%		-1.74%		11.20%		13.56%

Date: 9/2/2014

TABULATION OF BIDS

Page 2 Of 2

OWNER: Village of Lemont
 PROJECT DESCRIPTION: Building Demolition
 12897 Main Street, 10970 Archer Avenue, 10980 Archer Avenue, and 10990 Archer Avenue
 BID OPENING: August 29, 2014 at 10:00 am

PROJECT NO : 14270

				Engineers Estimate		Service Company 2625 South Loomis Chicago, IL 60608 5% Bid Bond		Omega Demolition Corp. 31W566 Spaulding Road Elgin, IL 60120 5% Bid Bond		National Wrecking Company 2441 North Leavitt Street Chicago, IL 60647-2005 5% Bid Bond		Alpine Demolition Services 3515 Stern Avenue St. Charles, IL 60174 5% Bid Bond			
Item No	Description	Unit	Quantity	Unit Price	Amount	Unit Price	Amount	Unit Price	Amount	Unit Price	Amount	Unit Price	Amount	Unit Price	Amount
1	Building Demolition, 12897 Main Street, Complete	L SUM	1	30,000.00	30,000.00	79,000.00	79,000.00	159,000.00	159,000.00	117,700.00	117,700.00	81,500.00	81,500.00		
2	Building Demolition, 10970 Archer Avenue, Complete	L SUM	1	30,000.00	30,000.00	22,000.00	22,000.00	29,000.00	29,000.00	28,400.00	28,400.00	35,700.00	35,700.00		
3	Building Demolition, 10980 Archer Avenue, Complete	L SUM	1	80,000.00	80,000.00	52,000.00	52,000.00	27,000.00	27,000.00	51,400.00	51,400.00	50,500.00	50,500.00		
4	Building Demolition, 10990 Archer Avenue, Complete	L SUM	1	30,000.00	30,000.00	49,000.00	49,000.00	27,000.00	27,000.00	40,400.00	40,400.00	64,000.00	64,000.00		
5	Water Service Disconnection, Complete	EACH	4	1,000.00	4,000.00	2,000.00	8,000.00	2,375.00	9,500.00	3,000.00	12,000.00	7,200.00	28,800.00		
6	Temporary Security Chain Link Fence, 6'-Height,	L SUM	1	5,000.00	5,000.00	5,000.00	5,000.00	1,000.00	1,000.00	5,000.00	5,000.00	3,600.00	3,600.00		
7	Asbestos Removal, 10990 Archer Avenue	L SUM	1	5,000.00	5,000.00	8,000.00	8,000.00	7,500.00	7,500.00	6,000.00	6,000.00	9,000.00	9,000.00		
8	Insurance Provisions - Complete	L SUM	1	8,000.00	8,000.00	6,000.00	6,000.00	0.00	0.00	10,100.00	10,100.00	8,462.00	8,462.00		
Totals:					192,000.00		229,000.00		260,000.00		271,000.00		281,562.00		
Bid Error Corrections:															
Corrected Totals ---							229,000.00		260,000.00		271,000.00		281,562.00		
Over / Under ----							37,000.00		68,000.00		79,000.00		89,562.00		
Percent ----							19.27%		35.42%		41.15%		46.65%		

to: Mayor Brian K. Reaves
Village Board of Trustees

from: James L. Cainkar, P.E., P.L.S., Acting Village Engineer

subject: **2014 Sanitary Sewer & Storm Sewer Cleaning & Televising**

date: September 3, 2014

BACKGROUND/HISTORY

Three (3) bids were received on August 29, 2014 @ 10:15 am for 2014 Sanitary Sewer and Storm Sewer Cleaning & Televising project, which includes the cleaning and televising of sanitary sewers and storm sewers, for a total length of 33,334 feet. The low bidder was Hydro-Vision Technology, 1593 Aster Drive, Romeoville, IL 60446, which bid was in the amount of \$69,768.00. The bid was \$3,854.20 (5.85%) above the Engineer's Estimate of \$65,913.80.

During the bidding process, the low bidder's bid package that was mailed to him, was damaged by rain. The bid addendum apparently was also damaged, and the bidder submitted a bid with the original bid packet. Though the bid items changed in format, the scope of work did not.

The bid included both the 2014 Village sanitary sewer cleaning project, as well as the televising of storm sewers in the Glens of Connemara, which is to be paid by the Developer. The price breakdown is as follows:

Village Sanitary Sewers	\$ 25,192.00
Glens of Connemara Storm Sewers	<u>\$ 44,576.00</u>
	\$ 69,768.00

RECOMMENDATION

Award the 2014 Sanitary Sewer & Storm Sewer Cleaning & Televising Project, to Hydro-Vision Technology, based on their bid amount of \$69,768.00.

ATTACHMENTS

- Resolution Authorizing Award of Contract
- Letter of Award Recommendation; and
- Bid Tabulation listing the bid received, including company name, address and amount of bid.

VILLAGE BOARD ACTION REQUIRED

Approval of Resolution awarding the contract to Hydro-Vision Technology.

RESOLUTION

**RESOLUTION AUTHORIZING AWARD OF CONTRACT
2014 Sanitary Sewer & Storm Sewer Cleaning & Televising**

WHEREAS, the Village of Lemont requires that the 2014 Sanitary Sewer & Storm Sewer Cleaning & Televising project, be completed; and

WHEREAS, the Village seeks to utilize the construction firm of Hydro-Vision Technology for such work; and

WHEREAS, Hydro-Vision Technology submitted a low bid for such work in the amount of \$69,768.00.

NOW, THEREFORE, BE IT RESOLVED, by the President and Board of Trustees that the Contract with Hydro-Vision Technology is hereby approved.

PASSED AND APPROVED BY THE PRESIDENT AND BOARD OF TRUSTEES OF THE VILLAGE OF LEMONT, COUNTIES OF COOK, WILL AND DuPAGE, ILLINOIS, on this 8th day of September, 2014.

AYES

NAYS

PASSED

ABSENT

Debby Blatzer
Paul Chialdikas
Clifford Miklos
Rick Sniegowski
Ronald Stapleton
Jeanette Virgilio

CHARLENE SMOLLEN, Village Clerk

Approved by me this 8th day of September, 2014.

Attest:

BRIAN K. REAVES, Village President

CHARLENE SMOLLEN, Village Clerk



Frank Novotny & Associates, Inc.

825 Midway Drive ♦ Willowbrook, IL ♦ 60527 ♦ Telephone: (630) 887-8640 ♦ Fax: (630) 887-0132

Civil Engineers/
Municipal Consultants

September 4, 2014

Mr. George Schafer
Administrator
Village of Lemont
418 Main Street
Lemont, Illinois 60439

Re: **2014 Sanitary Sewer & Storm Sewer
Cleaning and Televising**

Dear George:

Listed below and on the attached "Tabulation of Bids", please find the results of the August 29, 2014, bid opening for the above-captioned project. Three (3) bids were received and checked for accuracy. A summary is as follows:

Hydro-Vision Technology	\$ 69,768.00
National Power Rodding	154,562.80
United Septic	169,580.80
 Engineer's Estimate	 \$ 65,913.80

The low bid submitted by Hydro-Vision Technology, in the amount of \$69,768.00, is \$3,854.20 (5.85%) above the Engineer's Estimate of \$69,768.00. The bid includes both the Village sanitary sewer cleaning work, as well as the cleaning and televising of the storm sewers in the Glens of Connemara.

Hydro-Vision Technology is qualified to perform this type of work. We, therefore, recommend that the Contract be awarded to **Hydro-Vision Technology, LLC, 1593 Aster Drive, Romeoville, IL 60446**, in the amount of **\$69,768.00**.

Should you have any questions concerning this matter, please do not hesitate to contact me.

Very truly yours,

FRANK NOVOTNY & ASSOCIATES, INC.

James L. Cainkar, P.E., P.L.S.

JLC/ce
Enclosure

cc: Mr. Ralph Pukula, Director of Public Works, w/Enc.
Ms. Christina Smith, Finance Director, w/Enc.
Ms. Linda Molitor, Executive Assistant, w/Enc.
File No. 14288

TABULATION OF BIDS

OWNER: Village of Lemont
 PROJECT DESCRIPTION: 2014 Sanitary Sewer & Storm Sewer Cleaning and Televising

PROJECT NO : 14288

BID OPENING:

				Engineers Estimate		National Power Rodding 2500 W. Arthington Street Chicago, IL 60612 5% Bid Bond		United Septic 1327 W. Beecher Road Bristol, IL 60512 5% Bid Bond		Hydro-Vision Technology 1593 Aster Drive Romeoville, IL 60446 5% Bid Bond	
Item No	Description	Unit	Quantity	Unit Price	Amount	Unit Price	Amount	Unit Price	Amount	Unit Price	Amount
Village System (Sanitary Sewers)											
1	Sanitary Sewer Cleaning, Light, 8", 10" or 12"	FOOT	14000	0.70	9,800.00	0.05	700.00	1.35	18,900.00		
2	Sanitary Sewer Cleaning, Heavy, 8", 10" or 12"	FOOT	2096	1.30	2,724.80	0.05	104.80	2.30	4,820.80		
3	Sanitary Sewer Televising	FOOT	16096	1.10	17,705.60	3.00	48,288.00	1.00	16,096.00		
Glens of Connemara (Storm Sewers)											
4	Storm Sewer Televising	FOOT	17894	1.10	19,683.40	5.00	89,470.00	6.00	107,364.00		
5	Storm Sewer Cleaning, Light, all sizes (for 3 man cleaning crew)	HOUR	32	500.00	16,000.00	500.00	16,000.00	700.00	22,400.00		
Village System (Sanitary Sewers)											
1	Sanitary Sewer Cleaning, Light, 8", 10" or 12"	FOOT	14000							0.50	7,000.00
2	Sanitary Sewer Cleaning, Heavy, 8", 10" or 12"	FOOT	2096							1.00	2,996.00
3	Sanitary Sewer Televising	FOOT	16096							1.00	16,096.00
Glens of Connemara (Storm Sewers)											
4	Storm Sewer Cleaning, Light, 8" or 12"	FOOT	8126							0.75	6,094.50
5	Storm Sewer Cleaning, Light, 15" or 18"	FOOT	3874							0.75	2,905.50
6	Storm Sewer Cleaning, Light, 24" or 30"	FOOT	4014							3.00	12,042.00
7	Storm Sewer Cleaning, Light, 36", 42" or 48"	FOOT	1880							3.00	5,640.00
8	Storm Sewer Televising	FOOT	17894							1.00	17,894.00
Totals :					65,913.80		154,562.80		169,580.80		70,668.00
Bid Error Corrections:											
Sanitary Sewer Cleaning, Heavy, 8", 10" or 12".....											2,096.00
Total.....											69,768.00
Corrected Totals ---							154,562.80		169,580.80		69,768.00
Over / Under ----							88,649.00		103,667.00		3,854.20
Percent ----							134.49%		157.28%		5.85%